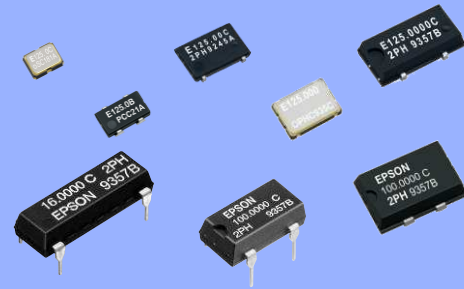

**CRYSTAL OSCILLATOR
PROGRAMMABLE**
SG - 8002 series

- Frequency range : 1 MHz to 125 MHz
- Supply voltage : 3.0 V / 3.3 V / 5.0 V
- Function : Output enable(OE) or Standby(\overline{ST})
- Short mass production lead time by PLL technology.
- SG-Writer available to purchase, please contact Epson Toyocom or local sales representative.

CE, LB, CA
Product Number (please contact us)

Specifications (characteristics)

Item	Symbol	Specifications *2			Conditions / Remarks
		PT / ST	PH / SH	PC / SC	
Output frequency range	f _o	1 MHz to 125 MHz		—	V _{CC} = 4.5 V to 5.5 V (except SG-8002LB)
		—	1 MHz to 80 MHz	—	V _{CC} = 4.5 V to 5.5 V (SG-8002LB only)
		—	—	1 MHz to 125 MHz	V _{CC} = 3.0 V to 3.6 V
		—	—	1 MHz to 66.7 MHz	V _{CC} = 2.7 V to 3.6 V
Supply voltage	V _{CC}	4.5 V to 5.5 V		2.7 V to 3.6 V	
Storage temperature	T _{stg}	-55 °C to +125 °C (SG-8002CA / JF / JA / DC / DB)			Store as bare product.
		-55 °C to +100 °C (SG-8002JC)			
Operating temperature	T _{use}	-40 °C to +125 °C (SG-8002CE / LB)			*1
		-20 °C to +70 °C / -40 °C to +85 °C			
Frequency tolerance	f _{tol}	B: ±50 × 10 ⁻⁶ , C: ±100 × 10 ⁻⁶			-20 °C to +70 °C
		M: ±100 × 10 ⁻⁶		M: ±100 × 10 ⁻⁶	-40 °C to +85 °C (except SG-8002JC) *3
		—	L: ±50 × 10 ⁻⁶	L: ±50 × 10 ⁻⁶	-40 °C to +85 °C (SG-8002LB only) *3
Current consumption	I _{CC}	40 mA Max. (SG-8002CE)		28 mA Max.	No load condition, Max. frequency
		30 mA Max. (SG-8002LB)			
		45 mA Max. (SG-8002CA / JF / JC / JA / DC / DB)			
Output disable current	I _{dis}	30 mA Max.		16 mA Max.	OE=GND (PT,PH,PC) (except SG-8002LB)
		—	25 mA Max.	16 mA Max.	OE=GND (PH,PC) (SG-8002LB only)
Stand-by current	I _{std}	50 µA Max.			\overline{ST} =GND (ST,SH,SC)
Symmetry *1	SYM	40 % to 60 %	—		TTL load: 1.4 V, Max. load condition (except SG-8002LB)
		—	40 % to 60 %		CMOS load: 50 % V _{CC} level, Max. load condition (except SG-8002LB)
		—	40 % to 60 %	—	50 % V _{CC} , L _{CMOS} =15 pF, ≤80 MHz (SG-8002LB)
		—	—	40 % to 60 %	50 % V _{CC} , L _{CMOS} =15 pF, V _{CC} =3.0 V to 3.6 V, ≤125 MHz (SG-8002LB)
		—	—	40 % to 60 %	50 % V _{CC} , L _{CMOS} =15 pF, V _{CC} =2.7 V to 3.6 V, ≤66.7 MHz (SG-8002LB)
High output voltage	V _{OH}	45 % to 55 %			*1
Low output voltage	V _{OL}	V _{CC} -0.4 V Min.			I _{OH} =-16 mA (PT,ST,PH,SH) , -8 mA (PC,SC)
Output load condition (TTL) *1	L _{TTL}	5 TTL Max.	—		I _{OL} =16 mA (PT,ST,PH,SH) , 8 mA (PC,SC)
		5 TTL Max.	—		Max. frequency and Max. Supply voltage (SG-8002CE / CA / JA / DC / DB)
Output load condition (CMOS) *1	L _{CMOS}	15 pF Max.			Max. frequency and Max. Supply voltage (SG-8002CE / JF / JC)
		—	15 pF Max.		Max. frequency and Max. Supply voltage (SG-8002LB)
		15 pF Max.	25 pF Max.	15 pF Max.	Max. frequency and Max. Supply voltage (SG-8002CA / JA / DC / DB)
Output enable / disable input voltage	V _{IH}	2.0 V Min.		70 % V _{CC} Min.	OE terminal or \overline{ST} terminal
	V _{IL}	0.8 V Max.		20 % V _{CC} Max.	
Rise / Fall time *1	tr/ tf	4 ns Max.	—		TTL load: 0.4 V to 2.4 V level (except SG-8002LB)
		—	3 ns Max.		CMOS load: 20 % V _{CC} to 80 % V _{CC} level
Start-up time	t _{str}	10 ms Max.			Time at minimum supply voltage to be 0 s
Frequency aging	f _{aging}	±5 × 10 ⁻⁶ / year Max.			+25 °C, V _{CC} =5.0 V / 3.3 V (PC,SC) First year

*1 Operating temperature, the available frequency, symmetry, output load conditions and rise/fall time, please refer to "Outline specifications" page.

*2 PLL-PLL connection & Jitter specification, please refer to "Jitter specifications and characteristics chart" page.

*3 Refer to "Outline specifications" (Frequency range) for "M" and "L" tolerance availability. Checking possible by the Frequency checking program.

External dimensions and Recommended footprint

(Unit:mm)

SG-8002CE Ceramic SON 4pin 3.2x2.5x1.05 mm

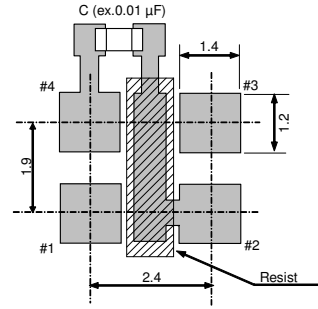
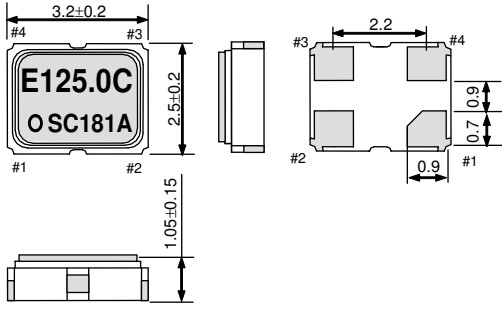

SG-8002LB SOJ 4pin 5.0x3.2x1.2 mm

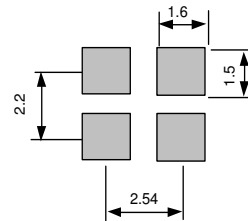
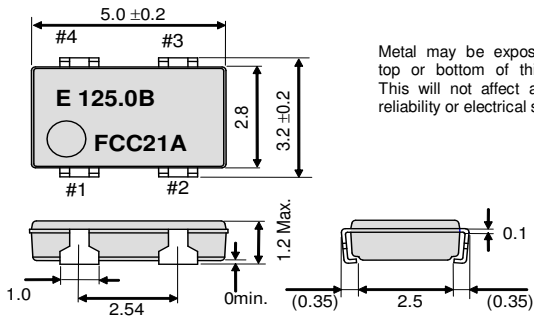

SG-8002CA Ceramic SON 4pin 7.0x5.0x1.4 mm

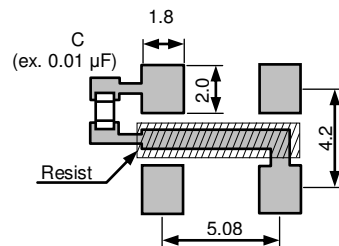
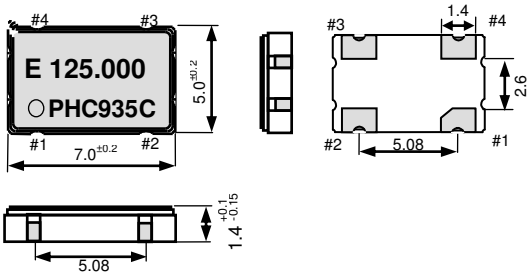

SG-8002JF SOJ 4pin 7.1x5.1x1.5 mm

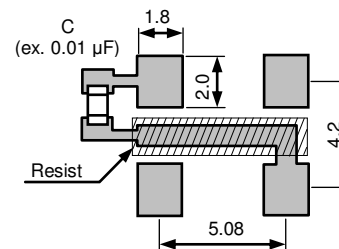
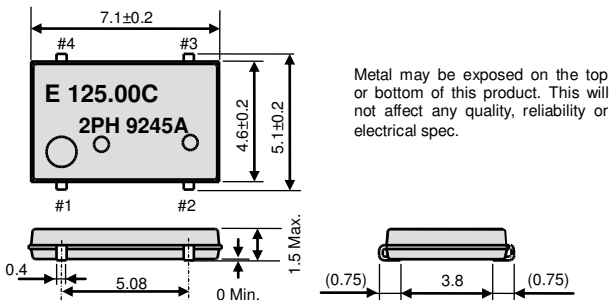

Note.

- OE Pin (PT, PH, PC)
- OE Pin = "H" or "open": Specified frequency output.
- OE Pin = "L": Output is high impedance.

- \overline{ST} Pin (ST, SH, SC)
- \overline{ST} Pin = "H" or "open": Specified frequency output.
- ST Pin = "L": Output is low level (weak pull - down), oscillation stops.

Pin map

Pin	Connection
1	OE or \overline{ST}
2	GND
3	OUT
4	VCC

To maintain stable operation, provide a 0.01µF to 0.1µF by-pass capacitor at a location as near as possible to the power source terminal of the crystal product (between Vcc - GND).



External dimensions and Recommended footprint (Continued)

(Unit:mm)

SG-8002JC **SOJ 4pin 10.5x5.8x2.7 mm** Package and pin compatible with SG-636.

Metal may be exposed on the top or bottom of this product. This will not affect any quality, reliability or electrical spec.

SG-8002JA **SOJ 4pin 14.0x9.8x4.7 mm** Package and pin compatible with SG-615.

SG-8002DC **DIP half size**

SG-8002DB **DIP full size**

Note.

- OE Pin (PT, PH, PC)
- OE Pin = "H" or "open": Specified frequency output.
- OE Pin = "L": Output is high impedance.

- \overline{ST} Pin (ST, SH, SC)
- ST Pin = "H" or "open": Specified frequency output.
- ST Pin = "L": Output is low level (weak pull - down), oscillation stops.

Pin map

Pin	Connection
1	OE or \overline{ST}
2	GND
3	OUT
4	VCC

Pin map: SG-8002DC

Pin	Connection
1	OE or \overline{ST}
4	GND
5	OUT
8	VCC

Pin map: SG-8002DB

Pin	Connection
1	OE or \overline{ST}
7	GND
8	OUT
14	VCC

To maintain stable operation, provide a 0.01uF to 0.1uF by-pass capacitor at a location as near as possible to the power source terminal of the crystal product (between Vcc - GND).

Products number

(Please contact us for each product.)

- SG-8002CE: Q3321CExxxxx00
- SG-8002LB: Q3323LBxxxxx00
- SG-8002CA: Q3309CAx0xxxx00
- SG-8002JF: Q3308JF x2xxxx00

- SG-8002JC: Q3307JCx2xxxx00
- SG-8002JA: Q3306JAx2xxxx00
- SG-8002DC: Q3204DCx2xxxx00
- SG-8002DB: Q3203DBx2xxxx00

SG-8002 Series Outline of specifications

Model		Supply voltage	Operating temperature	Output load condition	Symmetry		Output rise time / Output fall time	
SG-8002CE	PT/ST	4.5 V to 5.5 V	-20 °C to +70 °C	5TTL+15pF	40 % to 60 % (1.4 V, L_TTL=5 TTL+15 pF, f0≤125 MHz)	2.0 ns Max. (0.8 V to 2.0 V, L_TTL=Max.)	4.0 ns Max. (0.4 V to 2.4 V, L_TTL=Max.)	
			-40 °C to +85 °C		45 % to 55 % (1.4 V, L_TTL=5 TTL+15 pF, f0≤66.7 MHz)			
	PH/SH	-20 °C to +70 °C	15 pF (f0≤125 MHz)	40 % to 60 % (50 % VCC, L_CMOS=15 pF, f0≤125 MHz)	3.0 ns Max. (20 % VCC to 80 % VCC, L_CMOS=Max.)			
			-40 °C to +85 °C	25 pF (f0≤100 MHz)	45 % to 55 % (50 % VCC, L_CMOS=25 pF, f0≤66.7 MHz)			
			-40 °C to +85 °C	25 pF (f0≤27 MHz)	45 % to 55 % (50 % VCC, L_CMOS=25 pF, f0≤27.0 MHz)			
	PC/SC	3.0 V to 3.6 V 2.7 V to 3.6 V	-40 °C to +85 °C	15 pF	40 % to 60 % (50 % VCC, L_CMOS=15 pF, f0≤125 MHz)	3.0 ns Max. (20 % VCC to 80 % VCC, L_CMOS=Max.)		
					45 % to 55 % (50 % VCC, L_CMOS=15 pF, f0≤40 MHz)			
					40 % to 60 % (50 % VCC, L_CMOS=15 pF, f0≤66.7 MHz)			
SG-8002LB	PH/SH	4.5 V to 5.5 V	-40 °C to +85 °C	15 pF 25pF (f0≤50 MHz)	40 % to 60 % (50 % VCC, L_CMOS=15 pF, f0≤80 MHz)	3.0 ns Max. (20 % VCC to 80 % VCC, L_CMOS=Max.)		
					45 % to 55 % (50 % VCC, L_CMOS=25 pF, f0≤50 MHz)			
	PC/SC	3.0 V to 3.6 V 2.7 V to 3.6 V	-40 °C to +85 °C	15 pF	40 % to 60 % (50 % VCC, L_CMOS=15 pF, f0≤125 MHz)	3.0 ns Max. (20 % VCC to 80 % VCC, L_CMOS=Max.)		
					45 % to 55 % (50 % VCC, L_CMOS=15 pF, f0≤40 MHz)			
					40 % to 60 % (50 % VCC, L_CMOS=15 pF, f0≤66.7 MHz)			
SG-8002JF	PT/ST	4.5 V to 5.5 V	-20 °C to +70 °C	5TTL+15 pF (f0≤90 MHz)	40 % to 60 % (1.4 V, L_TTL=5 TTL+15 pF, f0≤90 MHz)	2.0 ns Max. (0.8 V to 2.0 V, L_CMOS≤25pF)	4.0 ns Max. (0.4 V to 2.4 V, L_CMOS or L_TTL=Max.)	
			-40 °C to +85 °C	15 pF (f0≤125 MHz)	↑ (1.4 V, L_CMOS=15 pF, f0≤125 MHz)			
				-40 °C to +85 °C	25 pF (f0≤66.7 MHz)	↑ (1.4 V, L_CMOS=25 pF, f0≤66.7 MHz)		
				-40 °C to +85 °C	15 pF (f0≤40 MHz)	45 % to 55 % (1.4 V, L_TTL=5 TTL+15 pF, f0≤66.7 MHz)		
					15 pF (f0≤125 MHz)	40 % to 60 % (1.4 V, L_CMOS=15 pF, f0≤40 MHz)		
					25 pF (f0≤90 MHz)	50 % VCC, L_CMOS=25 pF, f0≤125 MHz)		
	PH/SH		-20 °C to +70 °C	25 pF (f0≤90 MHz)	↑ (50 % VCC, L_CMOS=50 pF, f0≤50.0 MHz)	3.0 ns Max. (20 % VCC to 80 % VCC, L_CMOS≤25pF)		
				-40 °C to +85 °C	50 pF (f0≤50 MHz)	45 % to 55 % (50 % VCC, L_CMOS=25 pF, f0≤66.7 MHz)	4.0 ns Max. (20 % VCC to 80 % VCC, L_CMOS=Max.)	
			-40 °C to +85 °C	15 pF (f0≤40 MHz)	40 % to 60 % (50 % VCC, L_CMOS=15 pF, f0≤40 MHz)			
	PC/SC	3.0 V to 3.6 V 2.7 V to 3.6 V	-40 °C to +85 °C	15 pF	40 % to 60 % (50 % VCC, CL=15 pF, f0≤125 MHz)	3.0 ns Max. (20 % VCC to 80 % VCC, L_CMOS≤15pF)		
				-40 °C to +85 °C	30 pF (f0≤40 MHz)	45 % to 55 % (50 % VCC, CL=30 pF, f0≤40 MHz)	4.0 ns Max. (20 % VCC to 80 % VCC, L_CMOS=Max.)	
				15 pF	40 % to 60 % (50 % VCC, CL=15 pF, f0≤66.7 MHz)			
SG-8002CA	PT/ST	4.5 V to 5.5 V	-20 °C to +70 °C	5TTL+15pF (f0≤125 MHz)	40 % to 60 % (1.4 V, L_TTL=5 TTL+15 pF, f0≤125 MHz)	2.0 ns Max. (0.8 V to 2.0 V, L_CMOS or L_TTL=Max.)	4.0 ns Max. (0.4 V to 2.4 V, L_CMOS or L_TTL=Max.)	
			-40 °C to +85 °C	25 pF (f0≤66.7 MHz)	↑ (1.4 V, L_CMOS=25 pF, f0≤66.7 MHz)			
SG-8002JA			-40 °C to +85 °C	5 TTL+15 pF (f0≤40 MHz)	40 % to 60 % (1.4 V, L_CMOS=15 pF, f0≤55.0 MHz)			
				15 pF (f0≤55 MHz)	45 % to 55 % (1.4 V, L_TTL=5 TTL+15 pF, f0≤40.0 MHz)			
SG-8002DB	PH/SH		-20 °C to +70 °C	25 pF (f0≤125 MHz)	40 % to 60 % (50 % VCC, L_CMOS=25 pF, f0≤125 MHz)	3.0 ns Max. (20 % VCC to 80 % VCC, L_CMOS≤25pF)	4.0 ns Max. (20 % VCC to 80 % VCC, L_CMOS=Max.)	
				50 pF (f0≤66.7 MHz)	↑ (50 % VCC, L_CMOS=50 pF, f0≤66.7 MHz)			
SG-8002DC			-40 °C to +85 °C	15 pF (f0≤55 MHz)	45 % to 55 % (50 % VCC, L_CMOS=25 pF, f0≤66.7 MHz)			
				25 pF (f0≤40 MHz)	40 % to 60 % (50 % VCC, L_CMOS=15 pF, f0≤55.0 MHz)			
			-40 °C to +85 °C	50 pF (f0≤40 MHz)	45 % to 55 % (50 % VCC, L_CMOS=25 pF, f0≤40.0 MHz)			
	PC/SC	3.0 V to 3.6 V 2.7 V to 3.6 V	-40 °C to +85 °C	15 pF	40 % to 60 % (50 % VCC, L_CMOS=15 pF, f0≤125 MHz)	3.0 ns Max. (20 % VCC to 80 % VCC, L_CMOS≤15pF)		
				-40 °C to +85 °C	30 pF (f0≤40 MHz)	45 % to 55 % (50 % VCC, L_CMOS=30 pF, f0≤40 MHz)	4.0 ns Max. (20 % VCC to 80 % VCC, L_CMOS=Max.)	
				15 pF	40 % to 60 % (50 % VCC, L_CMOS=15 pF, f0≤66.7 MHz)			
SG-8002JC	PT/ST	4.5 V to 5.5 V	-20 °C to +70 °C	5TTL+15 pF (f0≤90 MHz)	40 % to 60 % (1.4 V, L_CMOS=15 pF, f0≤125 MHz)	2.0 ns Max. (0.8 V to 2.0 V, L_CMOS or L_TTL=Max.)	4.0 ns Max. (0.4 V to 2.4 V, L_CMOS or L_TTL=Max.)	
				15 pF (f0≤125 MHz)	↑ (1.4 V, L_TTL=5 TTL+15 pF, f0≤90.0 MHz)			
				-20 °C to +70 °C	25 pF (f0≤66.7 MHz)	↑ (1.4 V, L_CMOS=25 pF, f0≤66.7 MHz)		
				-20 °C to +70 °C	15 pF (f0≤125 MHz)	45 % to 55 % (1.4 V, L_TTL=5 TTL+15 pF, f0≤66.7 MHz)		
					25 pF (f0≤90 MHz)	40 % to 60 % (50 % VCC, L_CMOS=15 pF, f0≤125 MHz)	3.0 ns Max. (20 % VCC to 80 % VCC, L_CMOS≤25pF)	
					50 pF (f0≤66.7 MHz)	↑ (50 % VCC, L_CMOS=50 pF, f0≤50 MHz)	4.0 ns Max. (20 % VCC to 80 % VCC, L_CMOS=Max.)	
	PH/SH		-20 °C to +70 °C	15 pF (f0≤125 MHz)	45 % to 55 % (50 % VCC, L_CMOS=25 pF, f0≤66.7 MHz)			
				-40 °C to +85 °C	25 pF (f0≤90 MHz)	40 % to 60 % (50 % VCC, L_CMOS=15 pF, f0≤125 MHz)		
			-40 °C to +85 °C	50 pF (f0≤66.7 MHz)	45 % to 55 % (50 % VCC, L_CMOS=25 pF, f0≤66.7 MHz)			
	PC/SC	3.0 V to 3.6 V 2.7 V to 3.6 V	-20 °C to +70 °C	15 pF	40 % to 60 % (50 % VCC, L_CMOS=15 pF, f0≤125 MHz)	3.0 ns Max. (20 % VCC to 80 % VCC, L_CMOS≤15pF)		
				-20 °C to +70 °C	30 pF (f0≤40 MHz)	45 % to 55 % (50 % VCC, L_CMOS=30 pF, f0≤40 MHz)	4.0 ns Max. (20 % VCC to 80 % VCC, L_CMOS=Max.)	
				15 pF	40 % to 60 % (50 % VCC, L_CMOS=15 pF, f0≤66.7 MHz)			

▶ TABLE OF FREQUENCY RANGE

Model	Supply voltage	Frequency	Frequency tolerance
SG-8002CE	PT/ ST PH/ SH	4.5 V to 5.5 V	1.0 MHz to 125 MHz 1.0 MHz to 27 MHz
	PC/SC	3.0 V to 3.6 V	1.0 MHz to 125 MHz
		2.7 V to 3.6 V	1.0 MHz to 66.7 MHz
SG-8002LB	PH/ SH	4.5 V to 5.5 V	1.0 MHz to 80 MHz 1.0 MHz to 27 MHz
		PC/ SC	3.0 V to 3.6 V
	2.7 V to 3.6 V		1.0 MHz to 66.7 MHz
SG-8002JF	PT/ ST PH/ SH	4.5 V to 5.5 V	1.0 MHz to 125 MHz 1.0 MHz to 40 MHz
	PC/ SC	3.0 V to 3.6 V	1.0 MHz to 125 MHz
		2.7 V to 3.6 V	1.0 MHz to 66.7 MHz
SG-8002CA SG-8002JA SG-8002DB SG-8002DC	PT/ ST PH/ SH	4.5 V to 5.5 V	1.0 MHz to 125 MHz 1.0 MHz to 55 MHz
	PC/ SC	3.0 V to 3.6 V	1.0 MHz to 125 MHz
		2.7 V to 3.6 V	1.0 MHz to 66.7 MHz
SG-8002JC	PT/ ST PH/ SH	4.5 V to 5.5 V	1.0 MHz to 125 MHz
	PC/ SC	3.0 V to 3.6 V	1.0 MHz to 125 MHz
		2.7 V to 3.6 V	1.0 MHz to 66.7 MHz

 Frequency tolerance: B:±50×10⁻⁶ (-20 °C to +70 °C), C:±100×10⁻⁶ (-20 °C to +70 °C), M:±100×10⁻⁶ (-40 °C to +85 °C), L:±50×10⁻⁶ (-40 °C to +85 °C)



SG-8002 series Jitter specifications and characteristics chart

■ PLL-PLL connection

Because we use a PLL technology, there are a few cases that the jitter value will increase when SG-8002 is connected to another PLL-oscillator.

In our experience, we are unable to recommend these products for the applications such as telecom carrier use or analog video clock use. Please be careful checking in advance for these application (Jitter specification is Max.250 ps/CL=15 pF)

Jitter Specifications

Model	Supply Voltage	Jitter Item	Specifications	Remarks
PT / PH ST / SH	5.0 V ±0.5 V	Cycle to cycle	150 ps Max.	33 MHz ≤ f ₀ ≤ 125 MHz, L_CMOS=15 pF
			200 ps Max.	1.0 MHz ≤ f ₀ < 33 MHz, L_CMOS=15 pF
		Peak to peak	200 ps Max.	33 MHz ≤ f ₀ ≤ 125 MHz, L_CMOS=15 pF
			250 ps Max.	1.0 MHz ≤ f ₀ < 33 MHz, L_CMOS=15 pF
SC / PC	3.3 V ±0.3 V	Cycle to cycle	200 ps Max.	1.0 MHz ≤ f ₀ ≤ 125 MHz, L_CMOS=15 pF
		Peak to peak	250 ps Max.	1.0 MHz ≤ f ₀ ≤ 125 MHz, L_CMOS=15 pF

■ Remarks on noise management for power supply line

We do not recommend inserting filters or other devices in the power supply line as the counter measure of EMI noise reduction.

This device insertion might cause high-frequency impedance high in the power supply line and it affects oscillator stable drive.

When this measure is required, please evaluate circuitry and device behavior in the circuit and verify that it will not affect oscillation.

Start up time (0 % V_{cc} to 90 % V_{cc}) of power source should be more than 150 μs.

■ SG-8002 series Characteristics chart

