

**Built-in 32.768 kHz-DTCXO, High Stability  
I<sup>2</sup>C-Bus INTERFACE REAL TIME CLOCK MODULE**

**RX - 8803 SA / LC**

- Built in frequency adjusted 32.768 kHz crystal unit and DTCXO.
- 1/100s resolution Time register
- Interface Type : I<sup>2</sup>C-Bus interface (400kHz)
- Interface voltage range : 1.6 V to 5.5 V
- Temp. compensated voltage range : 2.2 V to 5.5 V
- Clock supply voltage range : 1.6 V to 5.5 V
- Selectable clock output (32.768 kHz, 1024 Hz, 1 Hz)
- The various functions include full calendar, alarm, timer, EVIN input.

\*The I<sup>2</sup>C-BUS is a trademark of NXP Semiconductors.



Product Number (Please contact us)  
RX-8803SA: X1B000152xxxx00  
RX-8803LC: X1B000142xxxx00



Actual size

RX-8803SA

RX-8803LC



**Block diagram**

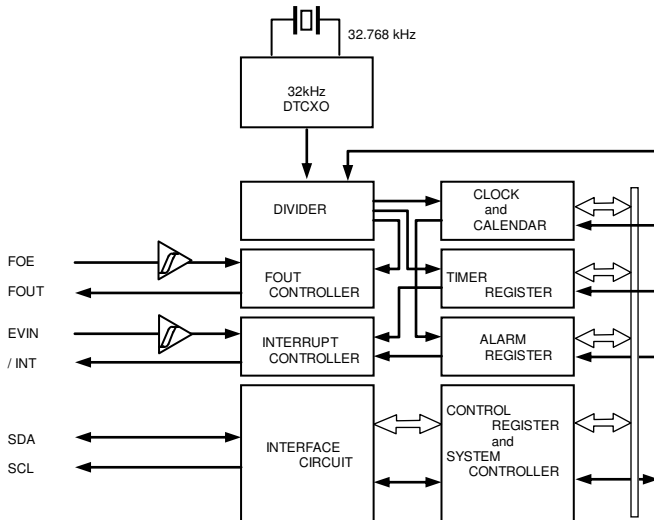

**Overview**

- **High Stability**
  - UA ± 3.4 × 10<sup>-6</sup> / -40 °C to +85 °C (Equivalent to 9 seconds of month deviation)
  - UB ± 5.0 × 10<sup>-6</sup> / -40 °C to +85 °C (Equivalent to 13 seconds of month deviation)
  - UC ± 5.0 × 10<sup>-6</sup> / -30 °C to +70 °C
  - AA (+5 ± 5.0) × 10<sup>-6</sup> / +25 °C
- **High Resolution:** 1/100s Time register with capture buffer
- **32.768 kHz frequency output function**
  - FOUT pin output (C-MOS output), CL=30 pF
  - Output selectable: 32.768 kHz, 1024 Hz, 1 Hz
- **The various interrupt**
  - Timer Function can be set between 1/ 4096 second and 4095 minutes.
  - Alarm Function can be set to day of week, day, hour, or minute.
  - EVIN input.
- **Time synchronize function with 1PPS signal input**
- **Register compatibility:** upper compatible with RX-8801.

\*It is possible to use it by the terminal connection as 32.768 kHz-DTCXO.

**Pin Function**

Signal Name	I / O	Function
T1(CE)	input	Use by the manufacture for testing. ( Do not connect externally.)
SCL	input	Serial clock input pin.
FOUT	Output	The pin outputs the reference clock signal. ( CMOS output )
TEST	input	Use by the manufacture for testing. ( Do not connect externally. RX-8803SA only.)
VDD	-	Connected to a positive power supply
FOE	input	The input pin for the FOUT output control.
EVIN	input	External event input.
/INT	Output	Interrupt output (N-ch. open drain).
GND	-	Connected to a ground
T2(VPP)	-	Use by the manufacture for testing. ( Do not connect externally.)
SDA	I/O	Data input and output pin.

**Terminal connection / External dimensions**

(Unit:mm)

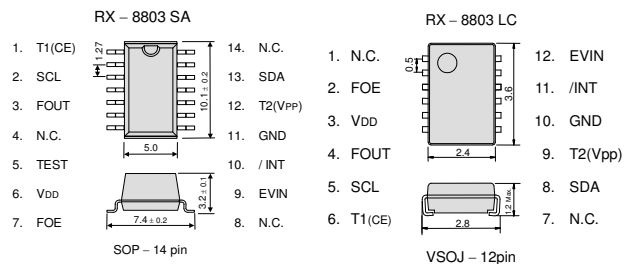

Metal may be exposed on the top or bottom of this product. This will not affect any quality, reliability or electrical spec.

**Specifications (characteristics)**

\* Refer to application manual for details.

■ Electrical Characteristics

Item	Symbol	Condition	Min.	Typ.	Max.	Unit	
Operating voltage	V <sub>DD</sub>	Interface voltage	1.6	3.0	5.5	V	
Temp. compensated Voltage	V <sub>TEM</sub>	Temp. compensated voltage	2.2	3.0	5.5	V	
Clock supply voltage	V <sub>CLK</sub>	-	1.6	3.0	5.5	V	
Operating temperature	T <sub>OPR</sub>	-	-40	+25	+85	°C	
Stability	Δf/f	UA Ta = -40 °C to +85 °C	±3.4 *1			× 10 <sup>-6</sup>	
		UB Ta = -40 °C to +85 °C	±5.0 *2				
		UC Ta = -30 °C to +70 °C					
		AA Ta = +25 °C	5 ± 5.0 *3				
Current consumption (1)	IDD1	Backup Mode FOE = GND, /INT = V <sub>DD</sub> FOUT output : OFF	V <sub>DD</sub> = 5V	-	1.2	3.4	μA
Current consumption (2)	IDD2		V <sub>DD</sub> = 3V	-	0.8	2.1	μA

\*1) Equivalent to 9 seconds of month deviation. \*2)\*3) Equivalent to 13 seconds of month deviation. (excluding offset)

■ 32.768 kHz-DTCXO Frequency temperature characteristics (Example)

