

High-Stability Frequency with Built in Timestamp and Power Switching

SPI-Bus REAL TIME CLOCK MODULE **NEW**

RX-4035 SA / LC

- Built-in 32.768 kHz crystal unit : Frequency adjusted for high accuracy. ($\pm 5 \times 10^{-6}$ / $T_a = +25^\circ\text{C}$)
- Interface Type : SPI-Bus (1MHz)
- Operating voltage range : 2.4 V to 5.5 V
- Timekeeping voltage range : 1.0 V to 5.5 V
- Low backup current : 350 nA (SA) 400 nA (LC) / 3 V (Typ.)
- Event detection and Time stamp : One-shot full timestamp and interrupt.
- Dual event detection ports : Each terminal has a de-bounce circuit.
- Auto power switching functions : When VDD deteriorates than 2.4V, internal source is switched to VBAT.



Product Number (Please contact us)
 RX-4035SA: X1B000192xxxx00
 RX-4035LC: X1B000202xxxx00



Actual size

RX-4035SA

RX-4035LC



Block diagram

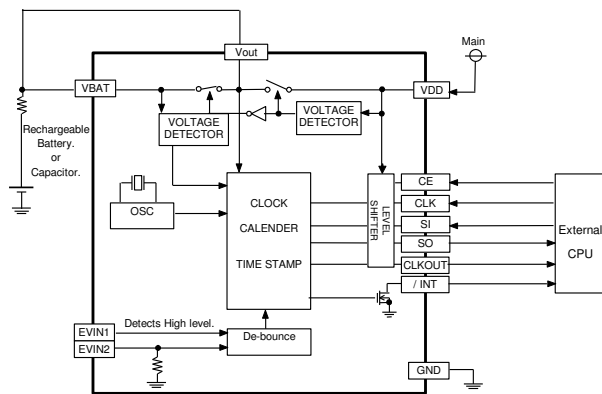

Overview

- **The event detection and Timestamp function**
 Dual event detection terminals.
 Selectable de-bounce period 35ms or 2s.
 Available event detection interrupt output.
- **Power switching functions.**
 - When VDD is less than 2.4V, an internal source is switched to VBAT.
 - Note: When the supply from VBAT, SPI interface are disabled.
- **Alarm, Periodic interrupt, 32.768kHz clock output.**
 - Available monthly-alarm and weekly-alarm.
 - Interrupt period are selectable from 2Hz to Monthly.
 - CLKOUT outputs 32.768kHz clock powered by VDD.

Pin function

Signal Name	Input / Output	Function
VBAT	—	Power supply for backup.
Vout	Output	Switched power out. (maximum output current 20mA)
CE	Input	SPI chip enable.
CLK	Input	SPI serial clock.
SO	Output	SPI data out.
SI	Input	SPI data in.
GND	—	Ground
EVIN1	Input	Event detection input 1
EVIN2	Input	Event detection input 2
/ INT	Output	Interrupt out.
CLKOUT	Output	32.768kHz output. (CMOS. Can not inhibit.)
N.C.	—	Do not connect.
VDD	—	Main power supply.

Terminal connection / External dimensions

(Unit:mm)

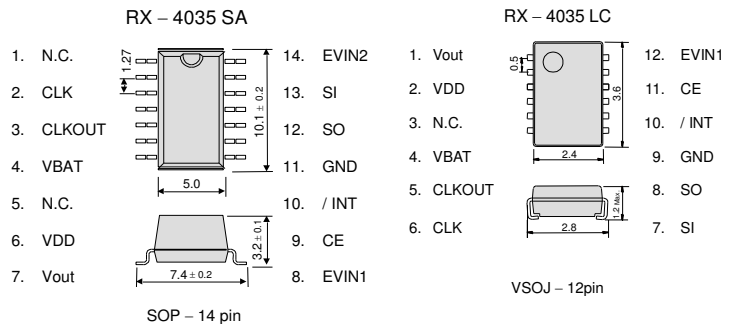

Metal may be exposed on the top or bottom of this product. This will not affect any quality, reliability or electrical spec.

Specifications (characteristics)

* Refer to application manual for details.

Recommended Operating Conditions

Item	Symbol	Condition	Min.	Typ.	Max.	Unit
Operating voltage	VACCESS	VDD	2.4	3.0	5.5	V
Time keeping voltage	VCLK	VBAT	1.0	3.0	5.5	V
Operating temperature	TOPR	—	-40	+25	+85	°C
Storage temperature	TSTG	—	-55	—	+125	°C

Frequency characteristics

Item	Symbol	Condition	Rating	Unit
Frequency tolerance	$\Delta f / f$	$T_a = +25^\circ\text{C}$ VBAT = 3.0 V	B: $5 \pm 23^{*1}$ AA: $5 \pm 5^{*2}$ AC: $0 \pm 5^{*2}$	$\times 10^{-6}$
Oscillation start-up time	tSTA	$T_a = +25^\circ\text{C}$ VDD = 3.0 V	1 Max.	s
Frequency / voltage characteristics	f / V	$T_a = +25^\circ\text{C}$ VDD = 2.4 V to 5.5 V	± 1 Max.	$\times 10^{-6}$

*1) Equivalent to 1 minute of monthly deviation (excluding offset.)
 *2) Equivalent to 13 seconds of monthly deviation (excluding offset.)

Current consumption characteristics

$T_a = -40^\circ\text{C}$ to $+85^\circ\text{C}$

Item	Symbol	Condition	Min.	Typ.	Max.	Unit
Current Consumption	IBAT	RX-4035SA VBAT = 3.0V, VDD = 0.0V CE = 0V, CLKOUT = open	-	350	1200	nA
		RX-4035LC VBAT = 3.0V, VDD = 0.0V CE = 0V, CLKOUT = open	-	400	-	-
	IDD	VDD = 3.0V CE = 0V CLKOUT = open	-	1.40	2.50	μA

Power supply detection voltage

$T_a = -40^\circ\text{C}$ to $+85^\circ\text{C}$

Item	Symbol	Condition	Min.	Typ.	Max.	Unit
VBAT detect voltage	VLOW	-	1.10	1.25	1.40	V
Power switching voltage (VDD to VBAT)	VD2B	+25 °C	2.328	2.40	2.472	V