

Advanced PMU for CoreLogic LUCY

FEATURES

- Optimized for CoreLogic LUCY Processors
- Three Step-Down DC/DC Converters
- Four Low-Dropout Linear Regulators
- Integrated *ActivePath™* Charger
- I²C™ Serial Interface
- Advanced Enable/Disable Sequencing Controller
- Minimal External Components
- Tiny 5x5mm TQFN55-40 Package
 - 0.75mm Package Height
 - Pb-Free and RoHS Compliant

GENERAL DESCRIPTION

The ACT8933 is a complete, cost effective, highly-efficient *ActivePMU™* power management solution, optimized for the unique power, voltage-sequencing, and control requirements of the CoreLogic LUCY processors.

This device features three step-down DC/DC converters and four low-noise, low-dropout linear regulators, along with a complete battery charging solution featuring the advanced *ActivePath™* system-power selection function.

The three DC/DC converters utilize a high-efficiency, fixed-frequency (2MHz), current-mode PWM control architecture that requires a minimum number of external components. Two DC/DCs are capable of supplying up to 900mA of output current, while the third supports up to 700mA. All four low-dropout linear regulators are high-performance, low-noise regulators that supply up to 250mA each.

The ACT8933 is available in a compact, Pb-Free and RoHS-compliant TQFN55-40 package.

TYPICAL APPLICATION DIAGRAM

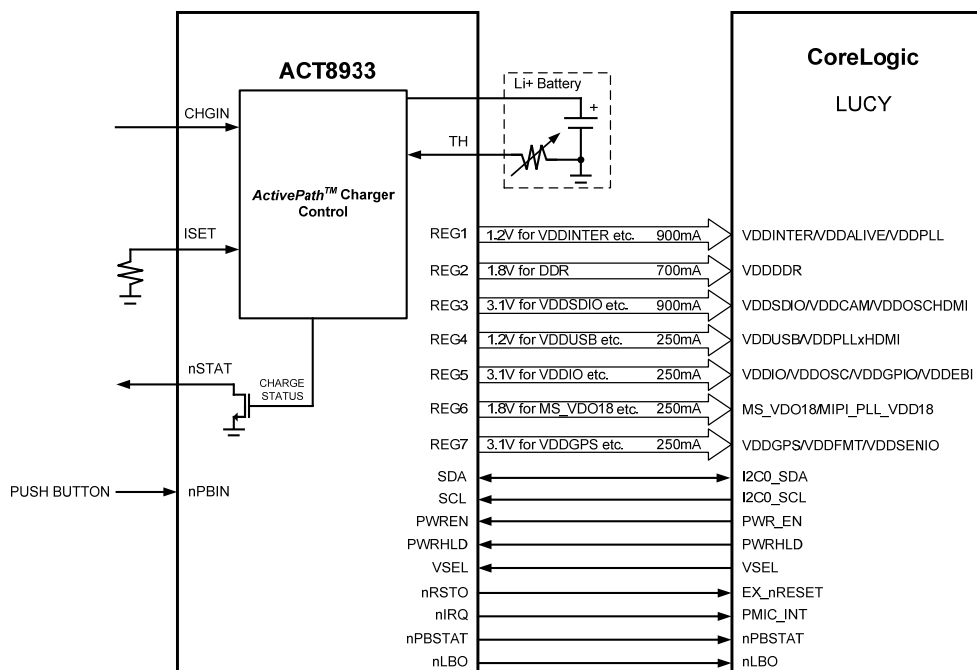

PRODUCT OPTIONS

Block	Function	Output Voltage	Capability
ActivePath	System Power Selection	4.6V	Up to 2A
CHGR	Battery Charger	4.2V	Programmable up to 1A
REG1	Step-Down DC/DC	Adjustable, or 0.6V to 3.9V	900mA
REG2	Step-Down DC/DC		700mA
REG3	Step-Down DC/DC		900mA
REG4	LDO	0.6V to 3.9V	250mA
REG5	LDO		250mA
REG6	LDO		250mA
REG7	LDO		250mA

FUNCTIONAL BLOCK DIAGRAM

