

30V/3A Sensorless CC/CV Step-Down DC/DC Converter

FEATURES

- 32V Input Voltage Surge
- 30V Steady State Input Voltage
- Up to 3A Output Current
- Output Voltage up to 12V
- Patent Pending Active CC Sensorless Constant Current Control
 - Integrated Current Control Improves Efficiency, Lowers Cost, and Reduces Component Count
- Resistor Programmable Current Limit from 1.5A to 3A
- $\pm 7.5\%$ CC Accuracy
 - Compensation of Input /Output Voltage Change
 - Temperature Compensation
 - Independent of inductance and Inductor DCR
- 2% Feedback Voltage Accuracy
- Up to 94% Efficiency
- 225kHz Switching Frequency Eases EMI Design
- Advanced Feature Set
 - Integrated Soft Start
 - Thermal Shutdown
 - Secondary Cycle-by-Cycle Current Limit
 - Protection Against Shorted ISET Pin
- SOP-8EP Package

APPLICATIONS

- USB Chargers
- LCD TV and Monitors
- Digital Video Recorders
- Set-Top Box
- Battery Chargers
- General-Purpose CC/CV Power Supplies

GENERAL DESCRIPTION

ACT4303 is a wide input voltage, high efficiency Active CC step-down DC/DC converter that operates in either CV (Constant Output Voltage) mode or CC (Constant Output Current) mode. ACT4303 provides up to 3A output current at 225kHz switching frequency.

Active CC is a patent-pending control scheme to achieve highest accuracy sensorless constant current control. Active CC eliminates the expensive, high accuracy current sense resistor, making it ideal for battery charging applications and adaptors with accurate current limit. The ACT4303 achieves higher efficiency than traditional constant current switching regulators by eliminating its associated power loss.

Protection features include cycle-by-cycle current limit, thermal shutdown, and frequency foldback at short circuit. The devices are available in a SOP-8EP package and require very few external devices for operation.

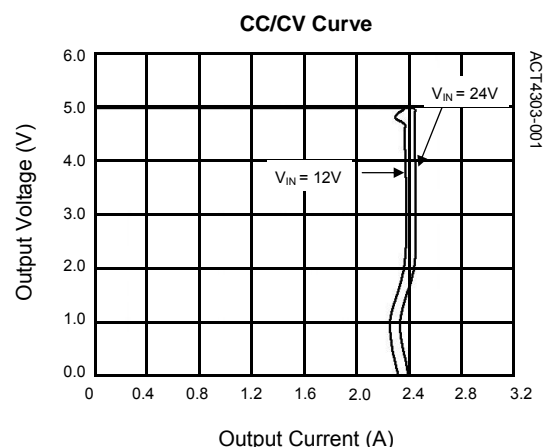
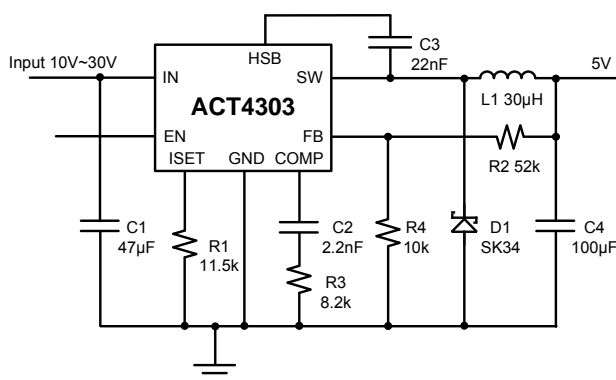

ORDERING INFORMATION

PART NUMBER	OPERATION TEMPERATURE RANGE	PACKAGE	PINS	PACKING
ACT4303YH-T	-40°C to 85°C	SOP-8EP	8	TAPE & REEL

PIN CONFIGURATION

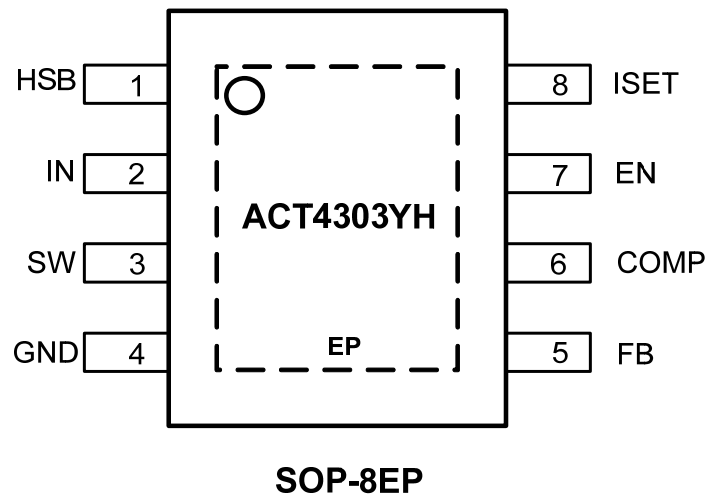

PIN DESCRIPTIONS

PIN	NAME	DESCRIPTION
1	HSB	High Side Bias Pin. This provides power to the internal high-side MOSFET gate driver. Connect a 22nF capacitor from HSB pin to SW pin.
2	IN	Power Supply Input. Bypass this pin with a 10μF ceramic capacitor to GND, placed as close to the IC as possible.
3	SW	Power Switching Output to External Inductor.
4	GND	Ground. Connect this pin to a large PCB copper area for best heat dissipation. Return FB, COMP, and ISET to this GND, and connect this GND to power GND at a single point for best noise immunity.
5	FB	Feedback Input. The voltage at this pin is regulated to 0.808V. Connect to the resistor divider between output and GND to set the output voltage.
6	COMP	Error Amplifier Output. This pin is used to compensate the converter.
7	EN	Enable Input. EN is pulled up to 5V with a 4μA current, and contains a precise 1.6V logic threshold. Drive this pin to a logic-high or leave unconnected to enable the IC. Drive to a logic-low to disable the IC and enter shutdown mode.
8	ISET	Output Current Setting Pin. Connect a resistor from ISET to GND to program the output current.
	Exposed Pad	Heat Dissipation Pad. Connect this exposed pad to large ground copper area with copper and vias.

ABSOLUTE MAXIMUM RATINGS^①

PARAMETER	VALUE	UNIT
IN to GND	-0.3 to 34	V
SW to GND	-1 to $V_{IN} + 1$	V
HSB to GND	$V_{SW} - 0.3$ to $V_{SW} + 7$	V
FB, EN, ISET, COMP to GND	-0.3 to + 6	V
Junction to Ambient Thermal Resistance	46	°C/W
Operating Junction Temperature	-40 to 150	°C
Storage Junction Temperature	-55 to 150	°C
Lead Temperature (Soldering 10 sec.)	300	°C

①: Do not exceed these limits to prevent damage to the device. Exposure to absolute maximum rating conditions for long periods may affect device reliability.

ELECTRICAL CHARACTERISTICS

($V_{IN} = 20V$, $T_A = 25^\circ C$, unless otherwise specified.)

PARAMETER	TEST CONDITIONS	MIN	TYP	MAX	UNIT
Input Voltage		10		30	V
V_{IN} UVLO Turn-On Voltage	Input Voltage Rising	9.0	9.4	9.7	V
V_{IN} UVLO Hysteresis	Input Voltage Falling		1.1		V
Standby Supply Current	$V_{EN} = 3V$, $V_{FB} = 1V$		0.9	1.4	mA
	$V_{EN} = 3V$, $V_{OUT} = 5V$, No load		3.0		mA
Shutdown Supply Current	$V_{EN} = 0V$		75	115	μA
Feedback Voltage		792	808	824	mV
Internal Soft-Start Time			400		μs
Error Amplifier Transconductance	$V_{FB} = V_{COMP} = 0.8V$, $\Delta I_{COMP} = \pm 10\mu A$		650		$\mu A/V$
Error Amplifier DC Gain			4000		V/V
Switching Frequency	$V_{FB} = 0.808V$	200	225	250	kHz
Foldback Switching Frequency	$V_{FB} = 0V$		30		kHz
Maximum Duty Cycle		85	88	91	%
Minimum On-Time			200		ns
COMP to Current Limit Transconductance	$V_{COMP} = 1.2V$		5.25		A/V
Secondary Cycle-by-Cycle Current Limit	Duty = D_{MAX}		4.5		A
Slope Compensation	Duty = D_{MAX}		1.2		A
ISET Voltage			1		V
ISET to IOOUT DC Room Temp Current Gain	IOOUT / ISET, $R_{ISET} = 19.6k\Omega$		25000		A/A
CC Controller DC Accuracy	$R_{ISET} = 19.6k\Omega$, $V_{OUT} = 3.5V$ Open-Loop DC Test	1175	1190	1205	mA
EN Threshold Voltage	EN Pin Rising	1.47	1.6	1.73	V
EN Hysteresis	EN Pin Falling		125		mV
EN Internal Pull-up Current			4		μA
High-Side Switch ON-Resistance			0.18		Ω
SW Off Leakage Current	$V_{EN} = V_{SW} = 0V$		1	10	μA
Thermal Shutdown Temperature	Temperature Rising		150		$^\circ C$
Thermal Shutdown Temperature Hysteresis	Temperature Falling		20		$^\circ C$

FUNCTIONAL BLOCK DIAGRAM

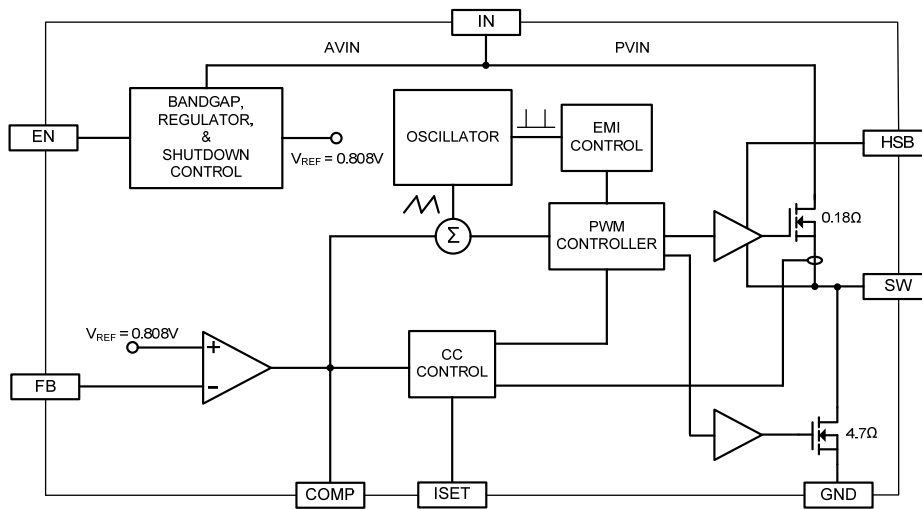

FUNCTIONAL DESCRIPTION

CV/CC Loop Regulation

As seen in *Functional Block Diagram*, the ACT4303 is a peak current mode pulse width modulation (PWM) converter with CC and CV control. The converter operates as follows:

A switching cycle starts when the rising edge of the Oscillator clock output causes the High-Side Power Switch to turn on and the Low-Side Power Switch to turn off. With the SW side of the inductor now connected to IN, the inductor current ramps up to store energy in the magnetic field. The inductor current level is measured by the Current Sense Amplifier and added to the Oscillator ramp signal. If the resulting summation is higher than the COMP voltage, the output of the PWM Comparator goes high. When this happens or when Oscillator clock output goes low, the High-Side Power Switch turns off.

At this point, the SW side of the inductor swings to a diode voltage below ground, causing the inductor current to decrease and magnetic energy to be transferred to output. This state continues until the cycle starts again. The High-Side Power Switch is driven by logic using HSB as the positive rail. This pin is charged to $V_{SW} + 5V$ when the Low-Side Power Switch turns on. The COMP voltage is the integration of the error between FB input and the internal 0.808V reference. If FB is lower than the reference voltage, COMP tends to go higher to increase current to the output. Output current will increase until it reaches the CC limit set by the ISET resistor. At this point, the device will transition from

regulating output voltage to regulating output current, and the output voltage will drop with increasing load.

The Oscillator normally switches at 225kHz. However, if FB voltage is less than 0.6V, then the switching frequency decreases until it reaches a typical value of 30kHz at $V_{FB} = 0.15V$.

Enable Pin

The ACT4303 has an enable input EN for turning the IC on or off. The EN pin contains a precision 1.6V comparator with 125mV hysteresis and a 4μA pull-up current source. The comparator can be used with a resistor divider from V_{IN} to program a startup voltage higher than the normal UVLO value. It can be used with a resistor divider from V_{OUT} to disable charging of a deeply discharged battery, or it can be used with a resistor divider containing a thermistor to provide a temperature-dependent shutoff protection for over temperature battery. The thermistor should be thermally coupled to the battery pack for this usage.

If left floating, the EN pin will be pulled up to roughly 5V by the internal 4μA current source. It can be driven from standard logic signals greater than 1.6V, or driven with open-drain logic to provide digital on/off control.

Thermal Shutdown

The ACT4303 disables switching when its junction temperature exceeds 150°C and resumes when the temperature has dropped by 20°C.

APPLICATIONS INFORMATION

Output Voltage Setting

Figure 1:

Output Voltage Setting

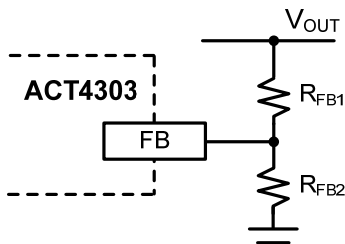

Figure 1 shows the connections for setting the output voltage. Select the proper ratio of the two feedback resistors R_{FB1} and R_{FB2} based on the output voltage. Typically, use $R_{FB2} \approx 10k\Omega$ and determine R_{FB1} from the following equation:

$$R_{FB1} = R_{FB2} \left(\frac{V_{OUT}}{0.808V} - 1 \right) \quad (1)$$

CC Current Setting

ACT4303 constant current value is set by a resistor connected between the ISET pin and GND. The CC output current is linearly proportional to the current flowing out of the ISET pin. The voltage at ISET is roughly 1V and the current gain from ISET to output is roughly 25000 (25mA/1μA). To determine the proper resistor for a desired current, please refer to Figure 2 below.

Figure 2:

Curve for Programming Output CC Current

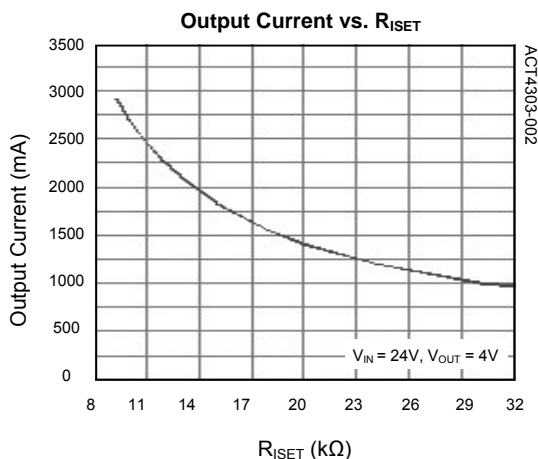

CC Current Line Compensation

When operating at constant current mode, the current limit increase slightly with input voltage. For wide input voltage applications, a resistor R_C is added to compensate line change and keep output high CC accuracy, as shown in Figure 3.

Figure 3:

Output Line Compensation

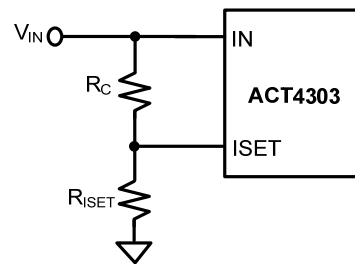

Inductor Selection

The inductor maintains a continuous current to the output load. This inductor current has a ripple that is dependent on the inductance value:

Higher inductance reduces the peak-to-peak ripple current. The trade off for high inductance value is the increase in inductor core size and series resistance, and the reduction in current handling capability. In general, select an inductance value L based on ripple current requirement:

$$L = \frac{V_{OUT} \times (V_{IN} - V_{OUT})}{V_{IN} f_{SW} I_{LOADMAX} K_{RIPPLE}} \quad (2)$$

where V_{IN} is the input voltage, V_{OUT} is the output voltage, f_{SW} is the switching frequency, $I_{LOADMAX}$ is the maximum load current, and K_{RIPPLE} is the ripple factor. Typically, choose $K_{RIPPLE} = 30\%$ to correspond to the peak-to-peak ripple current being 30% of the maximum load current.

With a selected inductor value the peak-to-peak inductor current is estimated as:

$$I_{LPK-PK} = \frac{V_{OUT} \times (V_{IN} - V_{OUT})}{L \times V_{IN} \times f_{SW}} \quad (3)$$

The peak inductor current is estimated as:

$$I_{LPK} = I_{LOADMAX} + \frac{1}{2} I_{LPK-PK} \quad (4)$$

APPLICATIONS INFORMATION CONT'D

The selected inductor should not saturate at I_{LPK} . The maximum output current is calculated as:

$$I_{OUTMAX} = I_{LIM} - \frac{1}{2} I_{LPK-PK} \quad (5)$$

I_{LIM} is the internal current limit, which is typically 3.2A, as shown in Electrical Characteristics Table.

External High Voltage Bias Diode

It is recommended that an external High Voltage Bias diode be added when the system has a 5V fixed input or the power supply generates a 5V output. This helps improve the efficiency of the regulator. The High Voltage Bias diode can be a low cost one such as IN4148 or BAT54.

Figure 4:

External High Voltage Bias Diode

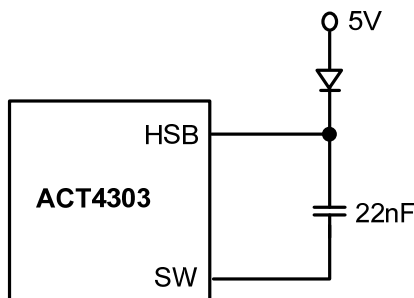

This diode is also recommended for high duty cycle operation and high output voltage applications.

Input Capacitor

The input capacitor needs to be carefully selected to maintain sufficiently low ripple at the supply input of the converter. A low ESR capacitor is highly recommended. Since large current flows in and out of this capacitor during switching, its ESR also affects efficiency.

The input capacitance needs to be higher than 10 μ F. The best choice is the ceramic type, however, low ESR tantalum or electrolytic types may also be used provided that the RMS ripple current rating is higher than 50% of the output current. The input capacitor should be placed close to the IN and G pins of the IC, with the shortest traces possible. In the case of tantalum or electrolytic types, they can be further away if a small parallel 0.1 μ F ceramic capacitor is placed right next to the IC.

Output Capacitor

The output capacitor also needs to have low ESR to keep low output voltage ripple. The output ripple voltage is:

$$V_{RIPPLE} = I_{OUTMAX} K_{RIPPLE} R_{ESR} + \frac{V_{IN}}{28 \times f_{SW}^2 L C_{OUT}} \quad (6)$$

Where I_{OUTMAX} is the maximum output current, K_{RIPPLE} is the ripple factor, R_{ESR} is the ESR of the output capacitor, f_{SW} is the switching frequency, L is the inductor value, and C_{OUT} is the output capacitance. In the case of ceramic output capacitors, R_{ESR} is very small and does not contribute to the ripple. Therefore, a lower capacitance value can be used for ceramic type. In the case of tantalum or electrolytic capacitors, the ripple is dominated by R_{ESR} multiplied by the ripple current. In that case, the output capacitor is chosen to have sufficiently low ESR.

For ceramic output capacitor, typically choose a capacitance of about 22 μ F. For tantalum or electrolytic capacitors, choose a capacitor with less than 50m Ω ESR.

Rectifier Diode

Use a Schottky diode as the rectifier to conduct current when the High-Side Power Switch is off. The Schottky diode must have current rating higher than the maximum output current and a reverse voltage rating higher than the maximum input voltage.

STABILITY COMPENSATION

Figure 5:
Stability Compensation

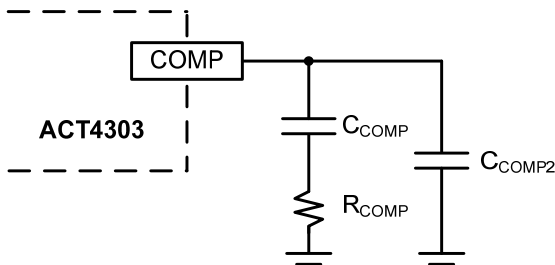

①: C_{COMP2} is needed only for high ESR output capacitor

The feedback loop of the IC is stabilized by the components at the COMP pin, as shown in Figure 5. The DC loop gain of the system is determined by the following equation:

$$A_{VDC} = \frac{0.808 V}{I_{OUT}} A_{VEA} G_{COMP} \quad (7)$$

The dominant pole P1 is due to C_{COMP}:

$$f_{P1} = \frac{G_{EA}}{2\pi A_{VEA} C_{COMP}} \quad (8)$$

The second pole P2 is the output pole:

$$f_{P2} = \frac{I_{OUT}}{2\pi V_{OUT} C_{OUT}} \quad (9)$$

The first zero Z1 is due to R_{COMP} and C_{COMP}:

$$f_{Z1} = \frac{1}{2\pi R_{COMP} C_{COMP}} \quad (10)$$

And finally, the third pole is due to R_{COMP} and C_{COMP2} (if C_{COMP2} is used):

$$f_{P3} = \frac{1}{2\pi R_{COMP} C_{COMP2}} \quad (11)$$

The following steps should be used to compensate the IC:

STEP 1. Set the cross over frequency at 1/10 of the switching frequency via R_{COMP}:

$$R_{COMP} = \frac{2\pi V_{OUT} C_{OUT} f_{SW}}{10 G_{EA} G_{COMP} \times 0.808 V} = 5.12 \times 10^7 V_{OUT} C_{OUT} \quad (\Omega) \quad (12)$$

STEP 2. Set the zero f_{Z1} at 1/4 of the cross over frequency. If R_{COMP} is less than 15kΩ, the equation for C_{COMP} is:

$$C_{COMP} = \frac{2.83 \times 10^{-5}}{R_{COMP}} \quad (F) \quad (13)$$

If R_{COMP} is limited to 15kΩ, then the actual cross over frequency is 6.58 / (V_{OUT}C_{OUT}). Therefore:

$$C_{COMP} = 6.45 \times 10^{-6} V_{OUT} C_{OUT} \quad (F) \quad (14)$$

STEP 3. If the output capacitor's ESR is high enough to cause a zero at lower than 4 times the cross over frequency, an additional compensation capacitor C_{COMP2} is required. The condition for using C_{COMP2} is:

$$R_{ESRCOUT} \geq (\text{Min } \frac{1.77 \times 10^{-6}}{C_{OUT}}, 0.006 \times V_{OUT}) \quad (\Omega) \quad (15)$$

And the proper value for C_{COMP2} is:

$$C_{COMP2} = \frac{C_{OUT} R_{ESRCOUT}}{R_{COMP}} \quad (16)$$

Though C_{COMP2} is unnecessary when the output capacitor has sufficiently low ESR, a small value C_{COMP2} such as 100pF may improve stability against PCB layout parasitic effects.

Table 1 shows some calculated results based on the compensation method above.

Table 1:
Typical Compensation for Different Output Voltages and Output Capacitors

V _{OUT}	C _{OUT}	R _{COMP}	C _{COMP}	C _{COMP2} ①
2.5V	47μF Ceramic CAP	5.6kΩ	3.3nF	None
3.3V	47μF Ceramic CAP	6.2kΩ	3.3nF	None
5V	47μF Ceramic CAP	8.2kΩ	3.3nF	None
2.5V	470μF/6.3V/30mΩ	39kΩ	22nF	47pF
3.3V	470μF/6.3V/30mΩ	45kΩ	22nF	47pF
5V	470μF/6.3V/30mΩ	51kΩ	22nF	47pF

①: C_{COMP2} is needed for high ESR output capacitor.
C_{COMP2} ≤ 47pF is recommended.

CC Loop Stability

The constant-current control loop is internally compensated over the 1500mA-3000mA output range. No additional external compensation is required to stabilize the CC current.

STABILITY COMPENSATION CONT'D

PC Board Layout Guidance

When laying out the printed circuit board, the following checklist should be used to ensure proper operation of the IC.

- 1) Arrange the power components to reduce the AC loop size consisting of C_{IN} , IN pin, SW pin and the schottky diode.
- 2) Place input decoupling ceramic capacitor C_{IN} as close to IN pin as possible. C_{IN} is connected power GND with vias or short and wide path.
- 3) Return FB, COMP and ISET to signal GND pin, and connect the signal GND to power GND at a single point for best noise immunity. Connect exposed pad to power ground copper area with copper and vias.
- 4) Use copper plane for power GND for best heat dissipation and noise immunity.
- 5) Place feedback resistor close to FB pin.
- 6) Use short trace connecting HSB- C_{HSB} -SW loop

Figure 7 gives a typical application schematic and associated BOM list.

Figure 6 shows an example of PCB layout.

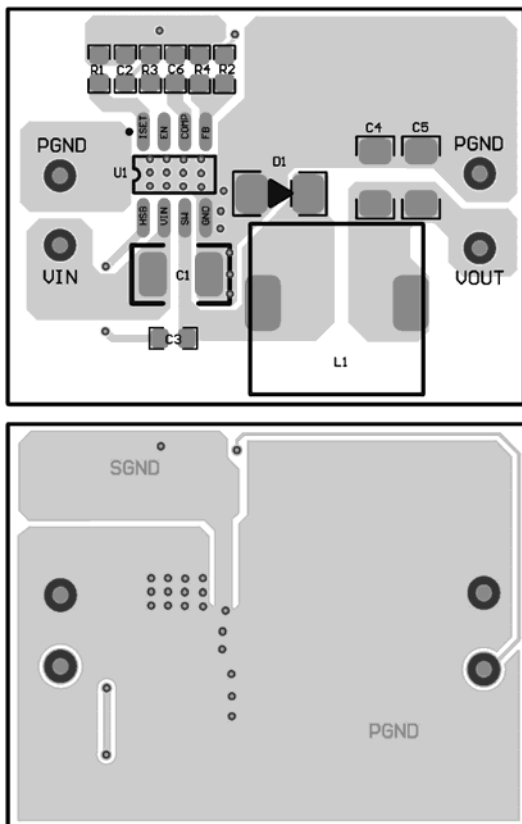

Figure 6: PCB Layout

Figure 7:
Typical Application Circuit for 5V/2.5A DC/DC Converter

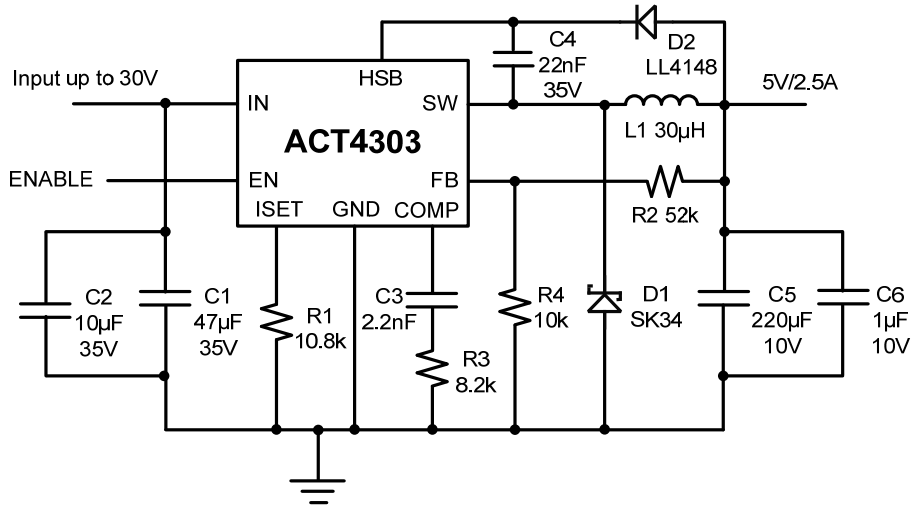
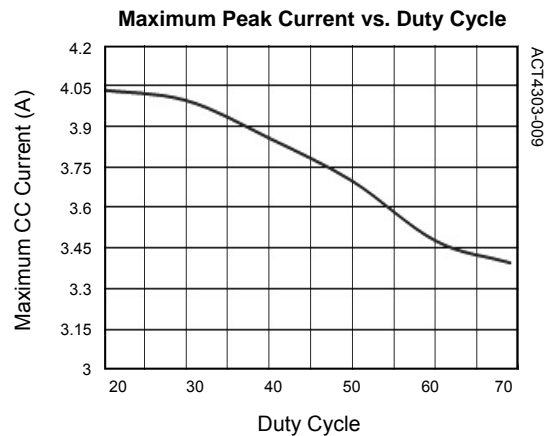
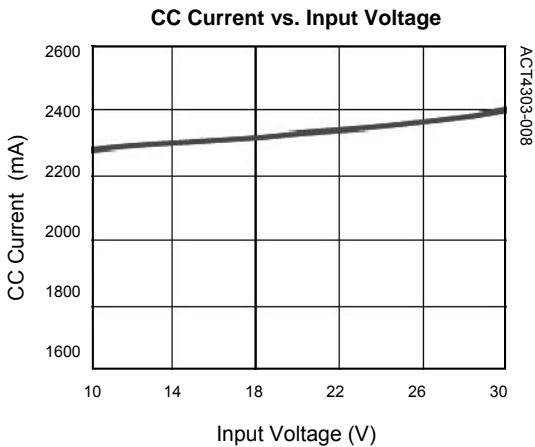
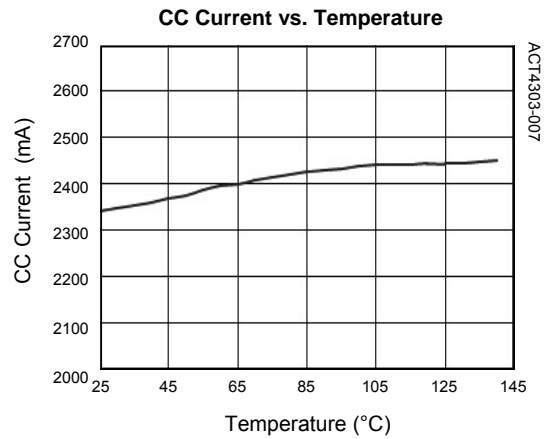
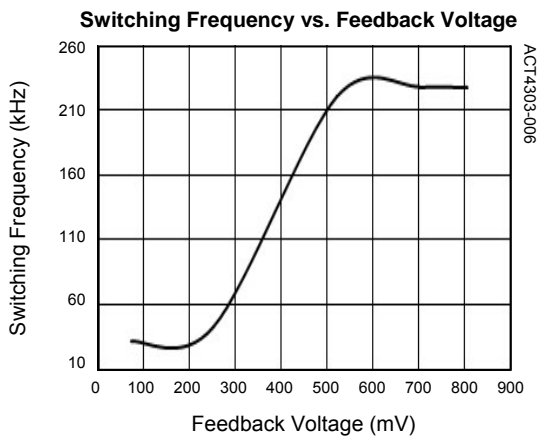
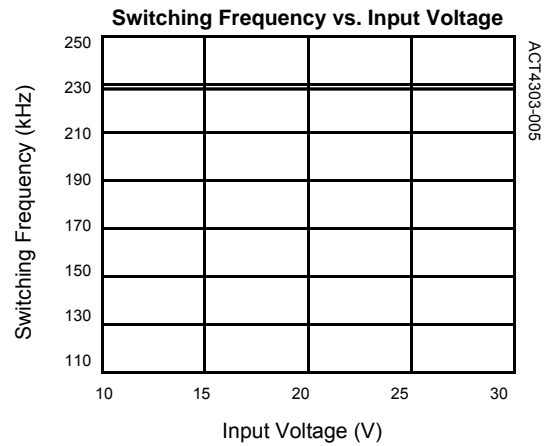
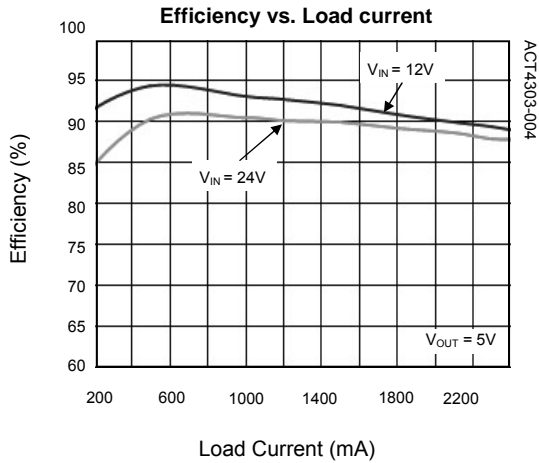

Table 2:
BOM List for 5V/2.5A DC/DC Converter

ITEM	REFERENCE	DESCRIPTION	MANUFACTURER	QTY
1	U1	IC, ACT4303YH, SOP-8EP	Active-Semi	1
2	C1	Capacitor, Electrolytic, 47µF/35V, 6.3x7mm	Murata, TDK	1
3	C2	Capacitor, Ceramic, 10µF/35V, 1206, SMD	Murata, TDK	1
4	C3	Capacitor, Ceramic, 2.2nF/6.3V, 0603, SMD	Murata, TDK	1
5	C4	Capacitor, Ceramic, 22nF/35V, 0603, SMD	Murata, TDK	1
6	C5	Capacitor, Electrolytic, 220µF/10V, 6.3x7mm	Murata, TDK	1
7	C6	Capacitor, Ceramic, 1µF/10V, 0603, SMD	Murata, TDK	1
8	L1	Inductor, 30µH, 3A, 20%, SMD	Tyco Electronics	1
9	D1	Diode, Schottky, 40V/3A, SK34	Diodes	1
10	D2	Diode, 75V/150mA, LL4148	Good-ARK	1
11	R1	Chip Resistor, 11.5kΩ, 0603, 1%	Murata, TDK	1
12	R2	Chip Resistor, 52kΩ, 0603, 1%	Murata, TDK	1
13	R3	Chip Resistor, 8.2kΩ, 0603, 5%	Murata, TDK	1
14	R4	Chip Resistor, 10kΩ, 0603, 1%	Murata, TDK	1

TYPICAL PERFORMANCE CHARACTERISTICS

(L = 33 μ H, C_{IN} = 10 μ F, C_{OUT} = 47 μ F, Ta = 25°C, R_{COMP} = 8.2k, C_{COMP1} = 2.2nF, C_{COMP2} = NC)



TYPICAL PERFORMANCE CHARACTERISTICS CONT'D

(L = 33 μ H, C_{IN} = 10 μ F, C_{OUT} = 47 μ F, T_a = 25°C, R_{COMP} = 8.2k, C_{COMP1} = 2.2nF, C_{COMP2} = NC)

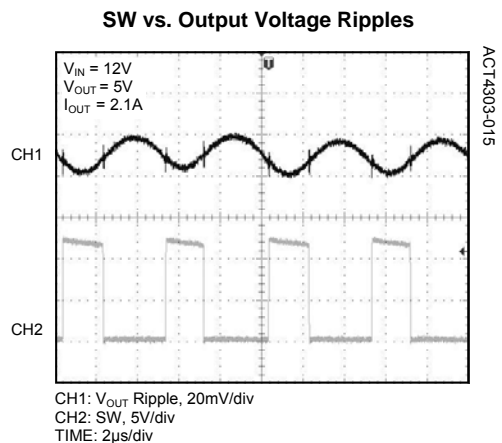
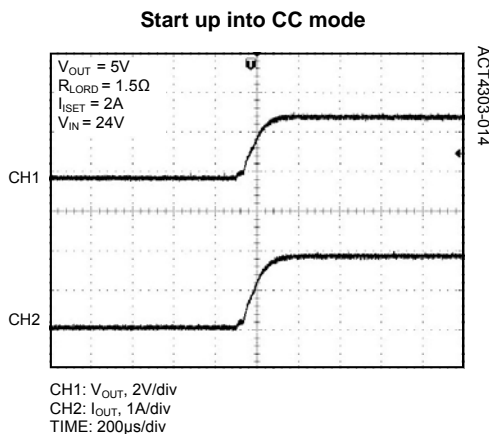
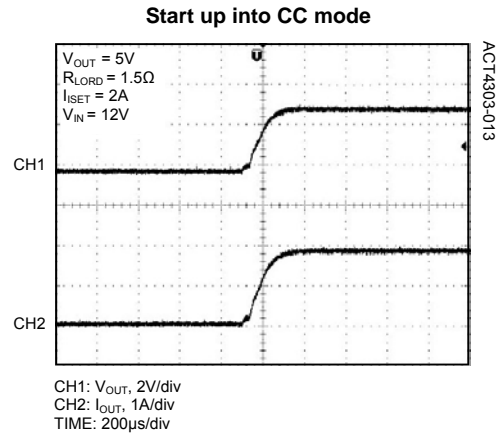
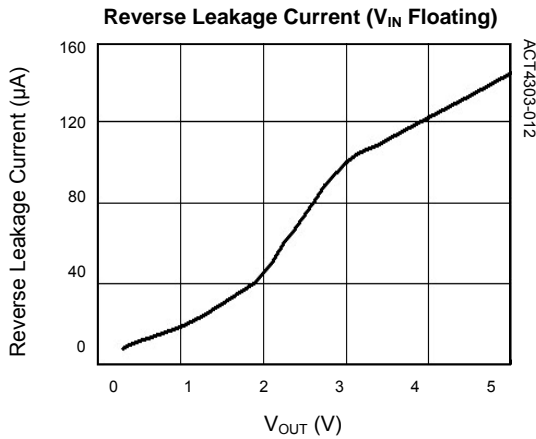
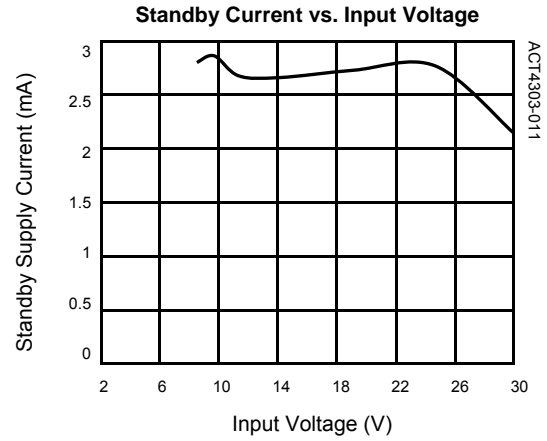
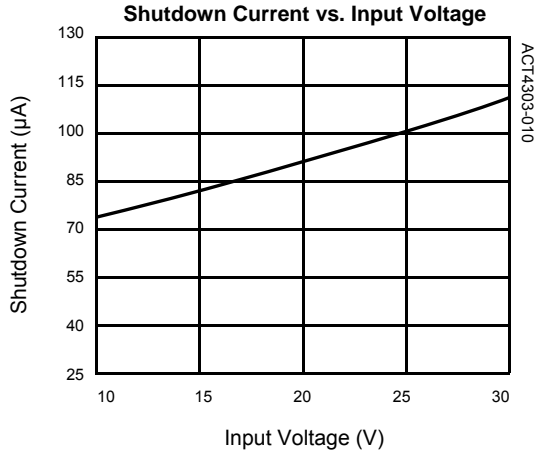

TYPICAL PERFORMANCE CHARACTERISTICS CONT'D

(L = 33 μ H, C_{IN} = 10 μ F, C_{OUT} = 47 μ F, Ta = 25°C, R_{COMP} = 8.2k, C_{COMP1} = 2.2nF, C_{COMP2} = NC)

SW vs. Output Voltage Ripple

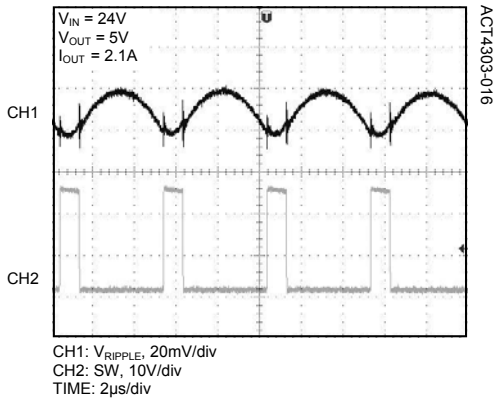

Start up with EN

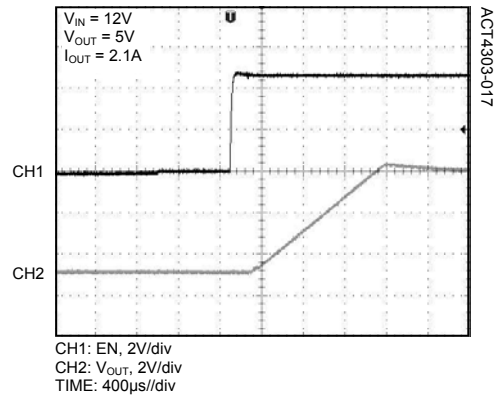

Start up with EN

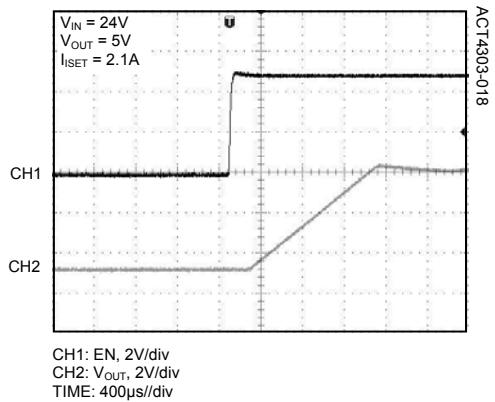

Load Step Waveforms

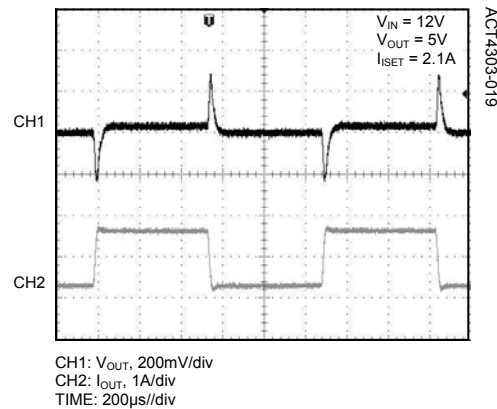

Load Step Waveforms

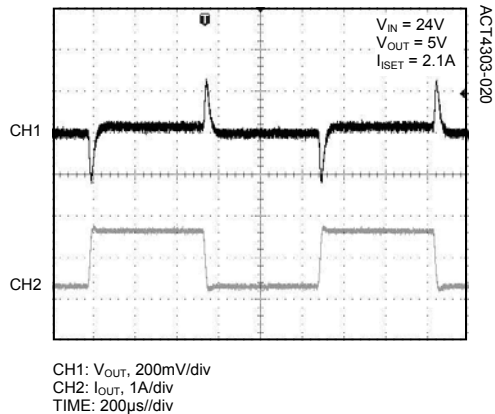

Short Circuit

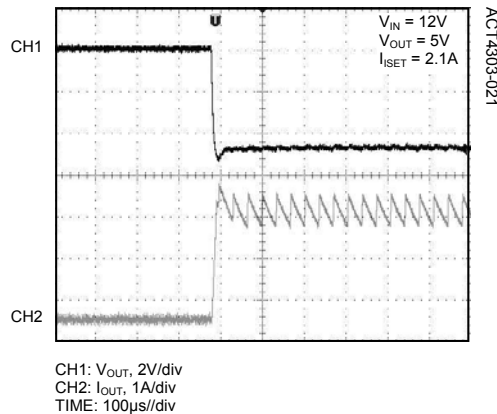

TYPICAL PERFORMANCE CHARACTERISTICS CONT'D

(L = 33 μ H, C_{IN} = 10 μ F, C_{OUT} = 47 μ F, Ta = 25°C, R_{COMP} = 8.2k, C_{COMP1} = 2.2nF, C_{COMP2} = NC)

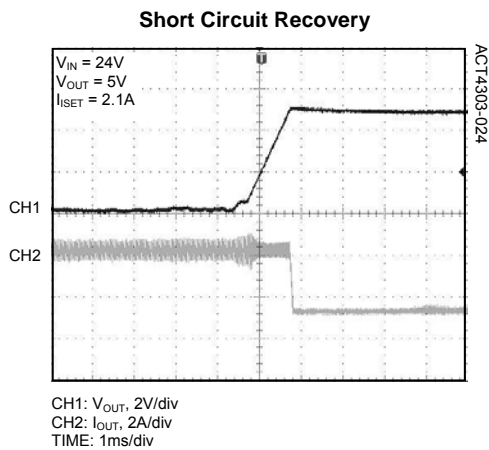
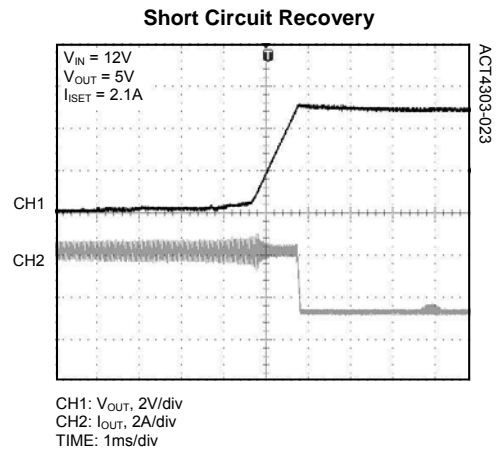
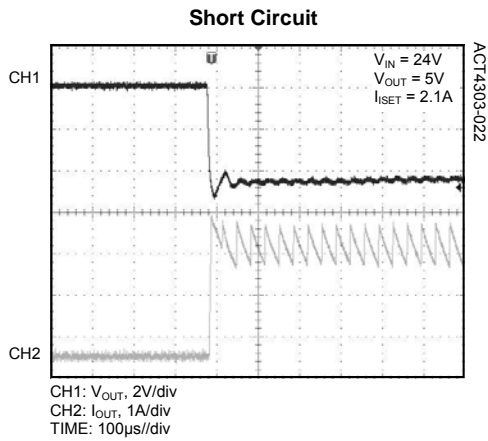

PACKAGE OUTLINE

SOP-8EP PACKAGE OUTLINE AND DIMENSIONS

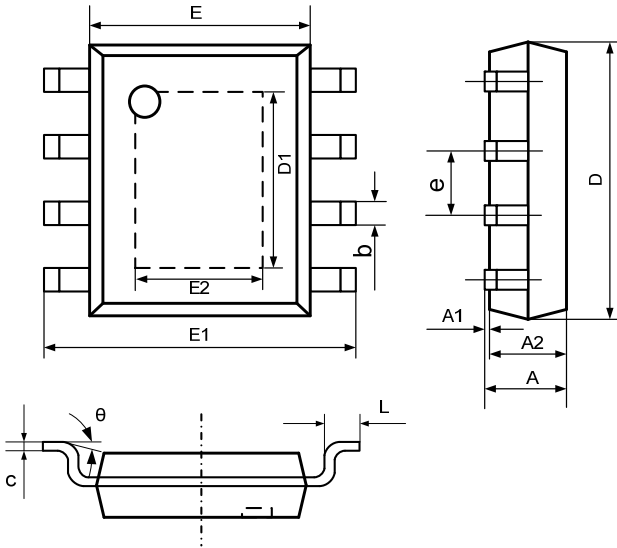

SYMBOL	DIMENSION IN MILLIMETERS		DIMENSION IN INCHES	
	MIN	MAX	MIN	MAX
A	1.350	1.700	0.053	0.067
A1	0.000	0.100	0.000	0.004
A2	1.350	1.550	0.053	0.061
b	0.330	0.510	0.013	0.020
c	0.170	0.250	0.007	0.010
D	4.700	5.100	0.185	0.200
D1	3.202	3.402	0.126	0.134
E	3.800	4.000	0.150	0.157
E1	5.800	6.200	0.228	0.244
E2	2.313	2.513	0.091	0.099
e	1.270 TYP		0.050 TYP	
L	0.400	1.270	0.016	0.050
θ	0°	8°	0°	8°

Active-Semi, Inc. reserves the right to modify the circuitry or specifications without notice. Users should evaluate each product to make sure that it is suitable for their applications. Active-Semi products are not intended or authorized for use as critical components in life-support devices or systems. Active-Semi, Inc. does not assume any liability arising out of the use of any product or circuit described in this datasheet, nor does it convey any patent license.

Active-Semi and its logo are trademarks of Active-Semi, Inc. For more information on this and other products, contact sales@active-semi.com or visit <http://www.active-semi.com>.

 Active-Semi® is a registered trademark of Active-Semi.