

1.5A, PWM Step-Down DC/DCs in TDFN

FEATURES

- Multiple Patents Pending
- Up to 95% High Efficiency
- Up to 1.5A Guaranteed Output Current (ACT8311)
- 1.35MHz Constant Frequency Operation
- Internal Synchronous Rectifier Eliminates Schottky Diode
- ACT8309: Up to 900mA
- ACT8310: Up to 1.2A
- ACT8311: Up to 1.5A
- 100% Duty Cycle Low-Dropout Operation
- 0.1µA Shutdown Current
- Small TDFN33-8 Package
– RoHS-Compliant
- Enable/Disable Control
- Minimal External Components

APPLICATIONS

- Wireless Handhelds
- Portable Devices
- GPS/PND equipment

GENERAL DESCRIPTION

The patent-pending ACT8309/ACT8310/ACT8311 are current-mode, fixed-frequency PWM, synchronous step-down DC/DC converters that are capable of delivering 1.5A with efficiency of up to 95%. These devices operate with a fixed frequency of 1.35MHz, minimizing noise in sensitive equipment as well as optimizing both efficiency and component size and cost.

These devices feature very low-resistance power MOSFET and 100% duty cycle operation, making them ideal choices for portable applications requiring a 3.0V or 3.3V rail to be generated from a Li+ battery.

The ACT8311 is capable of supplying up to 1.5A of output current, while the ACT8309 and ACT8310 are capable of supplying up to 900mA and 1.2A, respectively. All three devices have adjustable output voltages that are programmable down to 1.2V. Contact Active-Semi for custom fixed output voltage availability.

SYSTEM BLOCK DIAGRAM

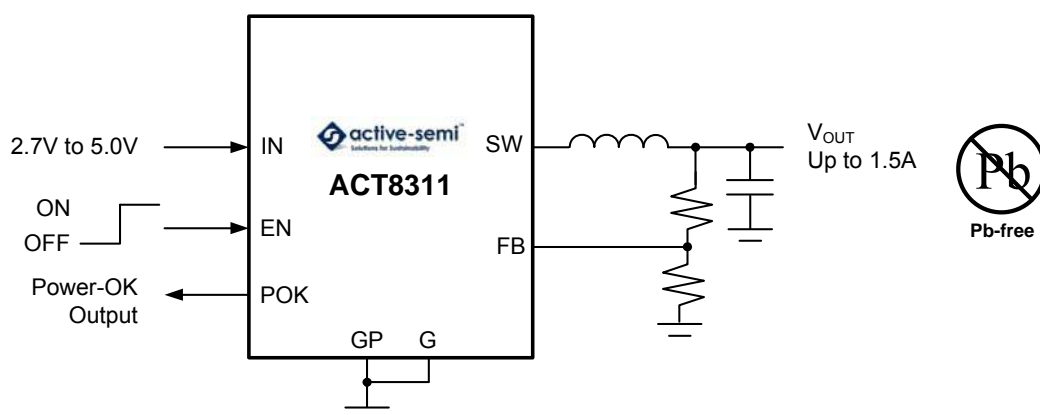

ORDERING INFORMATION

PART NUMBER	OUTPUT CURRENT	OUTPUT VOLTAGE	PACKAGE	PINS	TEMPERATURE RANGE
ACT8309NHADJ-T	0.9A	Adjustable	TDFN33-8	8	-40°C to +85°C
ACT8309NHxyz-T	0.9A	1.2V, 1.5V, 1.8V, 2.5V, 3.0V, 3.3V [Ⓞ]	TDFN33-8	8	-40°C to +85°C
ACT8310NHADJ-T	1.2A	Adjustable	TDFN33-8	8	-40°C to +85°C
ACT8310NHxyz-T	1.2A	1.2V, 1.5V, 1.8V, 2.5V, 3.0V, 3.3V [Ⓞ]	TDFN33-8	8	-40°C to +85°C
ACT8311NHADJ-T	1.5A	Adjustable	TDFN33-8	8	-40°C to +85°C
ACT8311NHxyz-T	1.5A	1.2V, 1.5V, 1.8V, 2.5V, 3.0V, 3.3V [Ⓞ]	TDFN33-8	8	-40°C to +85°C

Ⓞ: Fixed output voltage options are available for production subject to minimum order quantities. Contact Active-Semi for more information regarding fixed output voltage options.

PIN CONFIGURATION

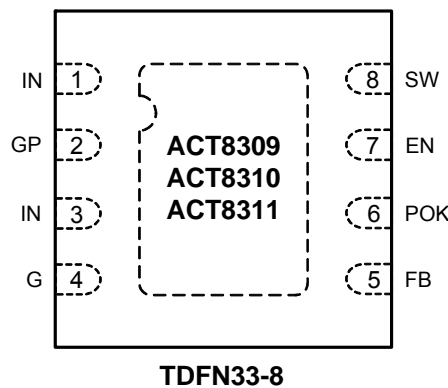

PIN DESCRIPTIONS

PIN	NAME	DESCRIPTION
1, 3	IN	Power Input. Bypass to GP close to IC with a high quality ceramic capacitor.
2	GP	Power Ground. Connect to G with a short trace.
4	G	Analog Ground. Connect to GP with a short trace.
5	FB	Feedback Node. For fixed output voltage versions, connect this pin directly to the output. For the adjustable output versions the voltage at this pin is regulated to 0.8V, connect to this pin to the center of the output feedback resistor divider for voltage setting.
6	POK	Open-Drain Power-OK Status Output. POK is an open-drain output which sinks current when the output voltage is less than 95% of the normal value. When the IC is disabled, POK is high impedance.
7	EN	Enable Input. When higher than 1.4V, this pin turns the IC on. When lower than 0.4V, this pin turn the IC off.
8	SW	Switch Output. Connect this pin to the switching end of the inductor.

ABSOLUTE MAXIMUM RATINGS^①

PARAMETER	VALUE	UNIT
IN, SW to GP	-0.3 to + 6	V
FB, EN, POK to G	-0.3 to + 6	V
FB, EN, SW Voltage	-0.3 to ($V_{IN} + 0.3, <6$)	V
GP to G	-0.3 to +0.3	V
Continuous SW Current	Internally limited	A
Junction to Ambient Thermal Resistance (θ_{JA})	61	°C/W
Maximum Power Dissipation (derate 5.3mW/°C above $T_A = 50^\circ\text{C}$)	1.63	W
Operating Junction Temperature	-40 to 150	°C
Storage Temperature	-55 to 150	°C
Lead Temperature (Soldering, 10 sec)	300	°C

①: Do not exceed these limits to prevent damage to the device. Exposure to absolute maximum rating conditions for long periods may affect device reliability.

ELECTRICAL CHARACTERISTICS

 ($V_{IN} = V_{EN} = 3.6V$, $T_A = 25^\circ C$, unless otherwise specified.)

PARAMETER	SYMBOL	TEST CONDITIONS	MIN	TYP	MAX	UNIT
Input Voltage Range	V_{IN}		2.7		5	V
Under Voltage Lockout Threshold	V_{UVLO}	V_{IN} rising, hysteresis = 80mV	2.35	2.5	2.6	V
Standby Supply Current		$V_{FB} = 103\%V_{FB,TYP}$, $I_{OUT} = 0$		150	310	μA
Shutdown Supply Current		EN = G, $V_{IN} = 4.2V$		0.1	1	μA
FB Voltage	V_{FB}	$T_A = 25^\circ C$	0.786	0.80	0.814	V
		$-40^\circ C < T_A < 85^\circ C$	0.776	0.80	0.824	
Output Voltage Accuracy		$T_A = 25^\circ C$	-2%	V_{NOM}	+2%	V
		$-40^\circ C < T_A < 85^\circ C$	-3%	V_{NOM}	+3%	
Output Voltage Line Regulation				0.06	0.4	%/V
Output Voltage Load Regulation				0.6		%
Current Limit		ACT8309NH	1.1	1.3	1.8	A
		ACT8310NH	1.4	1.7	2.2	
		ACT8311NH	1.75	2.1	2.8	
Max Output Current		ACT8309NH	0.9			A
		ACT8310NH	1.2			
		ACT8311NH	1.5			
Oscillator Frequency	f_{SW}	$V_{OUT} = 80\%$ of $V_{OUT,NOM}$	1.05	1.35	1.6	MHz
		$V_{FB} = 0.1V$		450		kHz
PMOS On-Resistance	R_{ONP}	ACT8309, $I_{SW} = -100mA$		0.15	0.234	Ω
		ACT8310, $I_{SW} = -100mA$		0.12	0.192	
		ACT8311, $I_{SW} = -100mA$		0.10	0.165	
NMOS On-Resistance	R_{ONN}	$I_{SW} = 100mA$		0.15	0.26	Ω
EN Logic High Threshold	V_{IH}	$V_{IN} = 2.7V$ to $5.0V$	1.4			V
EN Logic Low Threshold	V_{IL}	$V_{IN} = 2.7V$ to $5.0V$			0.4	V
EN Input Bias Current	I_{EN}	$V_{IN} = 5.0V$, EN = G or IN		0.01	0.1	μA
POK Threshold		% of $V_{OUT,NOM}$		95		%
POK Output Low Voltage	V_{OL}	$I_{POK} = 100\mu A$		0.008	0.012	V
POK Leakage Current	I_{POK}	$V_{POK} = 5.0V$		0.01	0.1	μA

Figure 1:
Functional Block Diagram

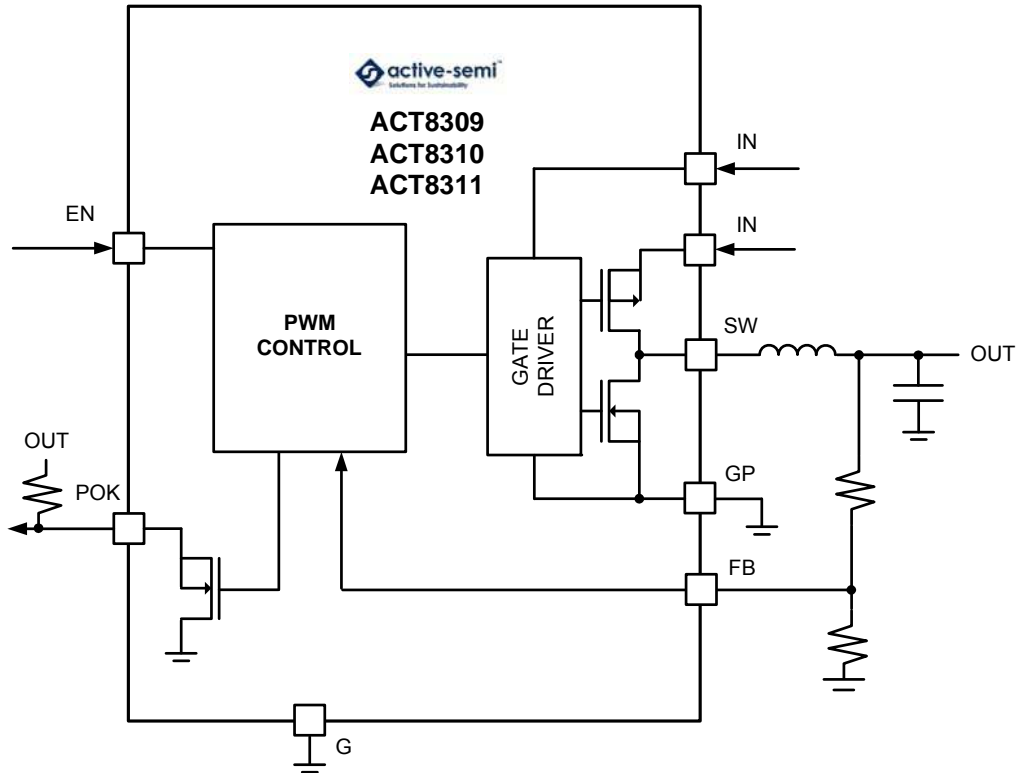
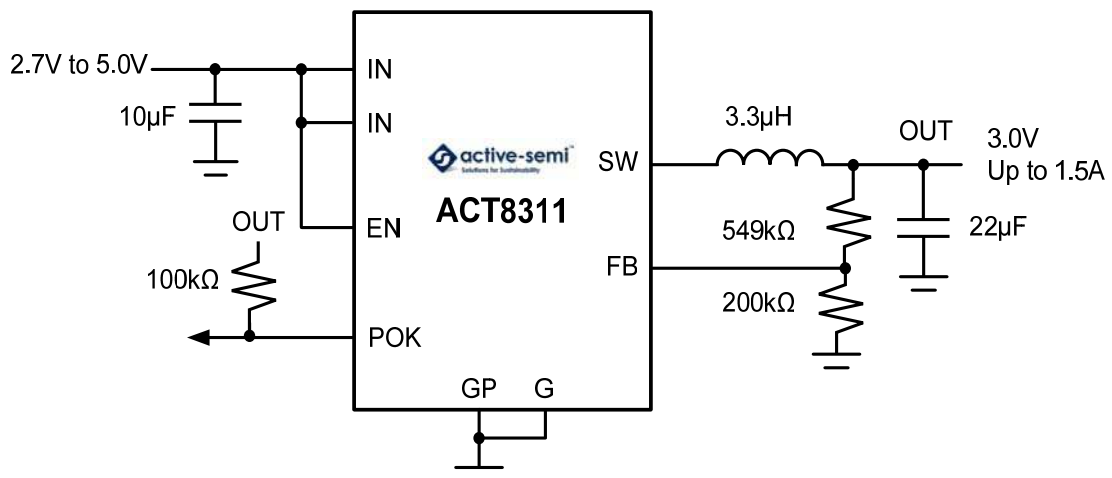

Figure 2:
Typical Application Circuit



FUNCTIONAL DESCRIPTION

The patent-pending ACT8309/ACT8310/ACT8311 are current-mode, fixed-frequency PWM, synchronous step-down DC/DC converters that are capable of delivering up to 1.5A (ACT8311) with efficiency of up to 95%. These devices feature very low-resistance power MOSFETs and 100% duty cycle operation, making them ideal choices for portable applications requiring a 3.0V or 3.3V rail to be generated from a Li+ battery. These devices operate with a fixed frequency of 1.35MHz, minimizing noise in sensitive equipment as well as optimizing both efficiency and component size and cost.

100% Duty Cycle Operation

These devices are capable of operating at up to 100% duty cycle operation. During 100% duty cycle operation, the high-side power MOSFET is held on continuously, providing a direct connection from the input to the output (through the inductor), ensuring the lowest possible dropout voltage in battery-powered applications.

Synchronous Rectification

The ACT8309/ACT8310/ACT8311 each feature integrated n-channel synchronous rectifiers, maximizing efficiency and minimizing the total solution size and cost by eliminating the need for external rectifiers.

Soft-Start

The ACT8309/ACT8310/ACT8311 each include integrated soft-start circuitry. When enabled, the output voltage track an internal 200µs soft-start ramp so that the output power up in a controlled, monotonic manner that is independent of loading.

Compensation

The ACT8309/ACT8310/ACT8311 each utilize current-mode control and a proprietary internal compensation scheme to simultaneously simplify external component selection and optimize transient performance over their full operating range. No compensation design is required, simply follow a few simple guidelines described below when choosing external components.

Capacitor Selection

The input capacitor reduces peak currents and noise induced upon the voltage source. A 10µF ceramic capacitor is recommended for most applications.

For most applications, a 22µF ceramic output capacitor is recommended. Although these regulators were designed to take advantage of the benefits of ceramic capacitors, namely small size and very-low ESR, low-ESR tantalum capacitors can provide acceptable results as well.

Inductor Selection

These devices were optimized for operation with 3.3µH inductors, although inductors in the 1.5µH to 4.7µH range may be used. Choose an inductor with a low DC-resistance, and avoid inductor saturation by choosing inductors with DC ratings that exceed the maximum output current of the application by at least 30%.

Output Voltage Setting

Figure 3 shows the feedback network necessary to set the output voltage when using adjustable output voltage options. Select components as follows: Set $R_{FB2} = 200k\Omega$, calculate R_{FB1} using the following equation:

$$R_{FB1} = R_{FB2} \left(\frac{V_{OUT}}{V_{FB}} - 1 \right)$$

Where V_{FB} is 0.8V.

Figure 3:
Output Voltage Setting

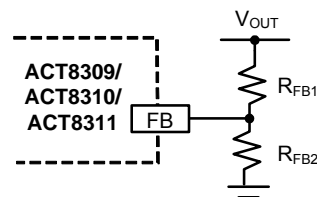

Enable/Disable Control

These devices may be enabled and disabled using the EN input. Drive EN to a logic-high to enable the regulator, drive EN to a logic-low to disable the regulator. When disabled, each regulator's quiescent supply current drops to less than 1µA.

Power-OK Output (POK)

These devices feature an open-drain "Power-OK" indicator output. This output sinks current whenever the output voltage is (typically) 5% below the regulation voltage, and goes high-impedance when the output voltage is above this threshold. To generate

a logic-level “Power-OK” signal, simply connect a pull-up resistor from POK to an appropriate output voltage.

PCB Layout Considerations

High switching frequencies and large peak current make PC board layout an important part of step-down DC/DC converter design. A good design minimizes excessive EMI on the feedback paths and voltage gradients in the ground plane, both of which can result in instability or regulation errors. Step-down DC/DCs exhibit discontinuous input current, so the input capacitors should be placed as close as possible to the IC, and avoiding the use of vias if possible. The inductor, input filter capacitor, and output filter capacitor should be connected as close together as possible, with short, direct, and wide traces. The ground nodes for each regulator’s power loop should be connected at a single point in a star-ground configuration, and this point should be connected to the backside ground plane with multiple vias. For fixed output voltage options the output node for each regulator should be connected to its corresponding FB pin through the shortest possible route, while keeping sufficient distance from switching nodes to prevent noise injection. Adjustable output versions should follow the same guidelines, but additionally connect the feedback resistors to the FB pin as close to the IC as possible to minimize noise injection.

TYPICAL PERFORMANCE CHARACTERISTICS

($V_{IN} = V_{EN} = 3.6V$, $T_A = 25^\circ C$, unless otherwise specified.)

ACT8309 Efficiency vs. Load Current

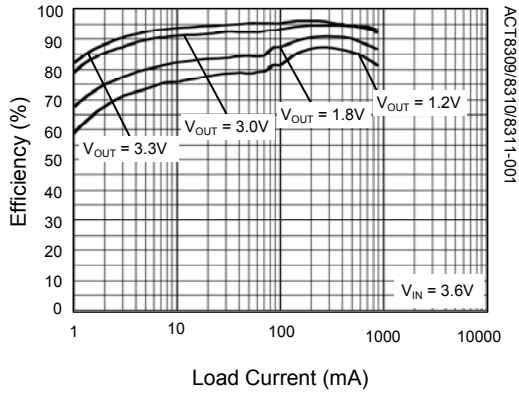

ACT8309 Dropout Voltage vs. Load Current

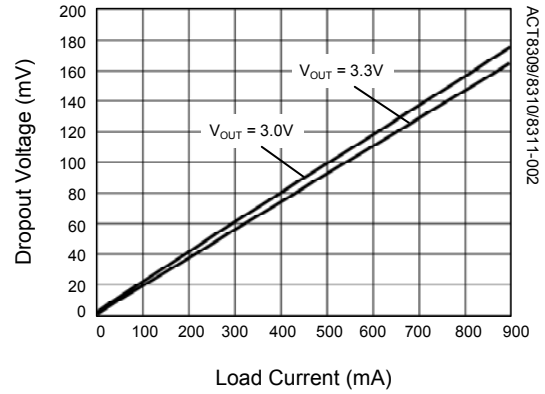

ACT8310 Efficiency vs. Load Current

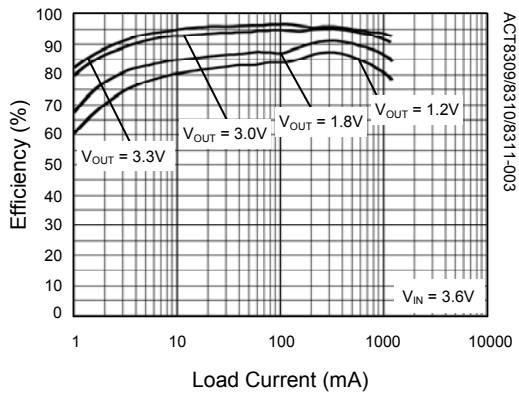

ACT8310 Dropout Voltage vs. Load Current

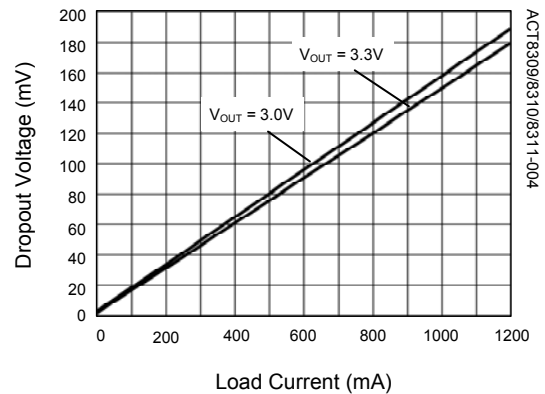

ACT8311 Efficiency vs. Load Current

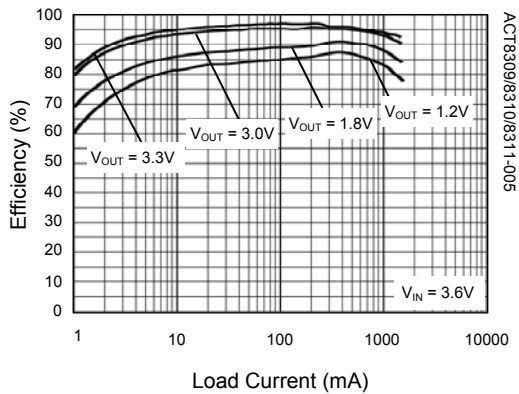

ACT8311 Dropout Voltage vs. Load Current

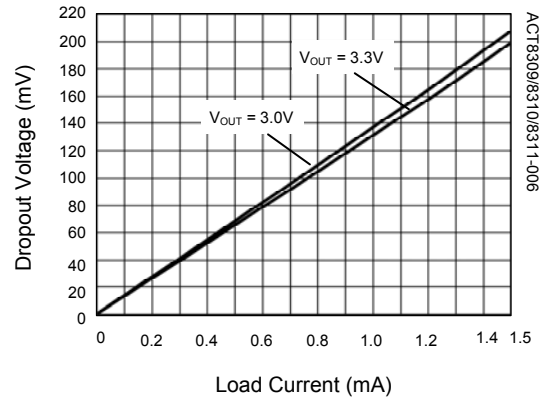

TYPICAL PERFORMANCE CHARACTERISTICS

($V_{IN} = V_{EN} = 3.6V$, $T_A = 25^\circ C$, unless otherwise specified.)

Startup Waveform

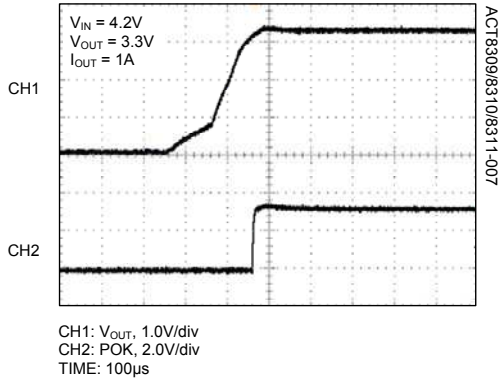

Load Transient Response

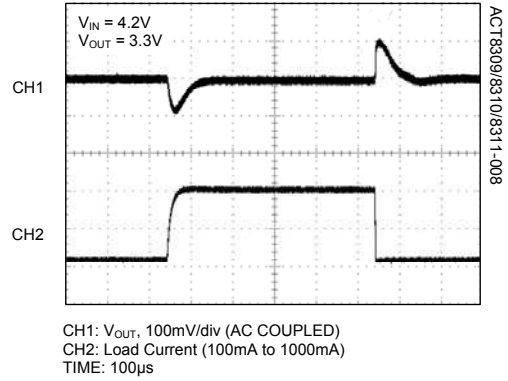

PACKAGE OUTLINE

TDFN33-8 PACKAGE OUTLINE AND DIMENSIONS

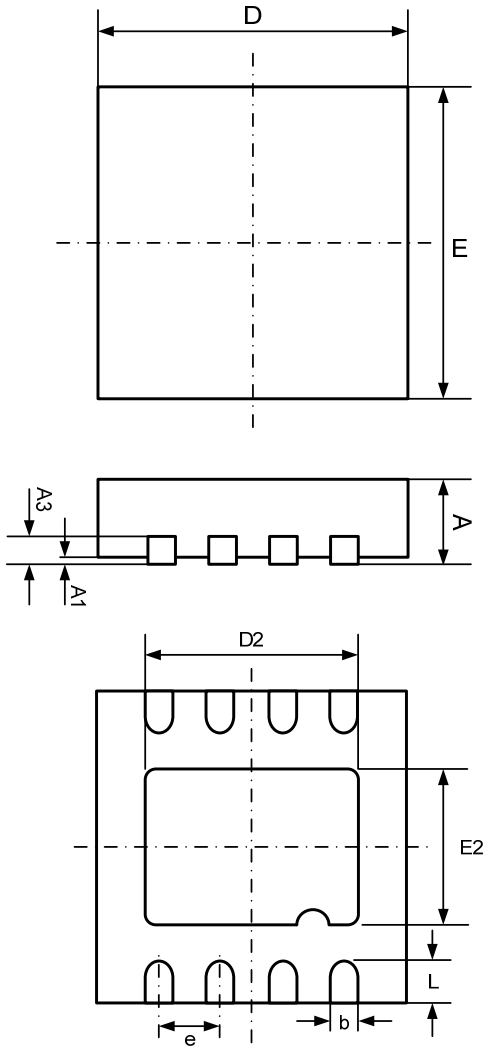

SYMBOL	DIMENSION IN MILLIMETERS		DIMENSION IN INCHES	
	MIN	MAX	MIN	MAX
A	0.700	0.800	0.028	0.031
A1	0.000	0.050	0.000	0.002
A3	0.153	0.253	0.006	0.010
D	2.900	3.100	0.114	0.122
E	2.900	3.100	0.114	0.122
D2	2.200	2.400	0.087	0.094
E2	1.400	1.600	0.055	0.063
b	0.200	0.320	0.008	0.013
e	0.650 TYP		0.026 TYP	
L	0.375	0.575	0.015	0.023

Active-Semi, Inc. reserves the right to modify the circuitry or specifications without notice. Users should evaluate each product to make sure that it is suitable for their applications. Active-Semi products are not intended or authorized for use as critical components in life-support devices or systems. Active-Semi, Inc. does not assume any liability arising out of the use of any product or circuit described in this datasheet, nor does it convey any patent license.

Active-Semi and its logo are trademarks of Active-Semi, Inc. For more information on this and other products, contact sales@active-semi.com or visit <http://www.active-semi.com>.

 is a registered trademark of Active-Semi.