

High Performance *ActivePSR*[™] Primary Switching Regulator

FEATURES

- Patented Primary Side Regulation Technology
- No Opto-Coupler
- Suitable Operation Frequency up to 85kHz
- Best-in-Class Constant Voltage Accuracy
- Proprietary Fast Startup with Big Capacitive Load
- Built-in Soft-Start Circuit
- Integrated Line and Primary Inductance Compensation
- Integrated Programmable Output Cord Resistance Compensation
- Line Under-Voltage, Output Over-Voltage, Output Short-Circuit and Over-Temperature Protection
- Complies with all Global Energy Efficiency and CEC Average Efficiency Standards
- Dedicate Adapter Application from 6W to 14W

APPLICATIONS

- RCC Adapter Replacements
- Linear Adapter Replacements
- Standby and Auxiliary Supplies

GENERAL DESCRIPTION

The ACT366 belongs to the high performance patented *ActivePSR*[™] Family of Universal-input AC/DC off-line controllers for adapter applications. It is designed for flyback topology working in discontinuous conduction mode (DCM). The ACT366 meets all of the global energy efficiency regulations (CEC, European Blue Angel, and US Energy Star standards) while using very few external components.

The ACT366 ensures safe operation with complete protection against all fault conditions. Built-in protection circuitry is provided for output short-circuit, output over-voltage, line under-voltage, and over temperature conditions.

The ACT366 *ActivePSR*[™] is optimized for high performance, cost-sensitive applications, and utilizes Active-Semi's proprietary primary-side feedback architecture to provide accurate constant voltage, constant current (CV/CC) regulation without the need of an opto-coupler or reference device. Integrated line and primary inductance compensation circuitry provides accurate constant current operation despite wide variations in line voltage and primary inductance. Integrated output cord resistance compensation further enhances output accuracy. The ACT366 achieves excellent regulation and transient response, yet requires less than 150mW of standby power.

The ACT366 is optimized for compact size 6W to 14W adapter applications. It is available in SOP-8/EP (Exposed Pad) package.

Figure 1:
Simplified Application Circuit

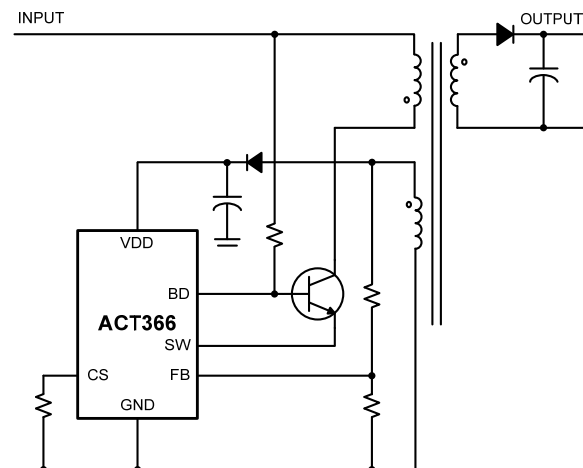

Table 1:
Output Power Table

PART NUMBER	85-265VAC	
	TYPICAL APPLICATION	Po MAX
ACT366YH-T (SOP-8/EP)	12V/1A	14W

ORDERING INFORMATION

PART NUMBER	TEMPERATURE RANGE	PACKAGE	PINS	PACKING METHOD	TOP MARK
ACT366YH-T	-40°C to 85°C	SOP-8/EP	8	TAPE & REEL	ACT366YH

PIN CONFIGURATION

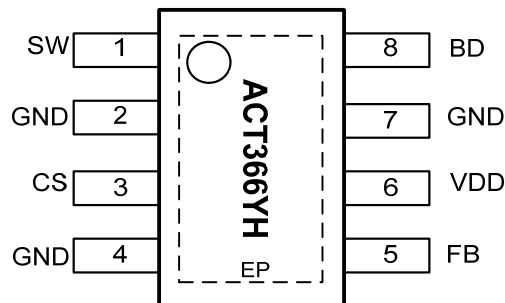

PIN DESCRIPTIONS

PIN	NAME	DESCRIPTION
1	SW	Switch Drive. Switch node for the external NPN transistor. Connect this pin to the external power NPN's emitter. This pin also supplies current to VDD during startup.
2,4,7	GND	Ground.
8	BD	Base Drive. Base driver for the external NPN transistor.
6	VDD	Power Supply. This pin provides bias power for the IC during startup and steady state operation.
5	FB	Feedback Pin. Connect this pin to a resistor divider network from the auxiliary winding.
3	CS	Current Sense Pin. Connect an external resistor (R_{CS}) between this pin and ground to set peak current limit for the primary switch. The peak current limit is set by $(0.396V \times 0.9) / R_{CS}$. For more detailed information, see Application Information.
EP	EP	Exposed Pad shown as dashed box. The exposed thermal pad should be connected to board ground plane and pin 4. The ground plane should include a large exposed copper pad under the package for thermal dissipation (see package outline). The leads and exposed pad should be flush with the board, without offset from the board surface.

ABSOLUTE MAXIMUM RATINGS^①

PARAMETER	VALUE	UNIT
VDD, BD, SW to GND	-0.3 to + 28	V
Maximum Continuous VDD Current	100	mA
FB, CS to GND	-0.3 to + 6	V
Continuous SW Current	Internally limited	A
Maximum Power Dissipation (derate 6.7mW/°C above T _A = 50°C)	1.8	W
Junction to Ambient Thermal Resistance (θ_{JA})	46	°C/W
Operating Junction Temperature	-40 to 150	°C
Storage Junction	-55 to 150	°C
Lead Temperature (Soldering, 10 sec)	300	°C

①: Do not exceed these limits to prevent damage to the device. Exposure to absolute maximum rating conditions for long periods may affect device reliability.

ELECTRICAL CHARACTERISTICS

(V_{DD} = 14V, V_{OUT} = 5V, L_P = 1.5mH, N_P = 140, N_S = 7, N_A = 19, T_A = 25°C, unless otherwise specified.)

PARAMETER	SYMBOL	TEST CONDITIONS	MIN	TYP	MAX	UNIT
Supply						
VDD Turn-On Voltage	V _{DDON}	V _{DD} Rising from 0V	17.6	18.6	19.6	V
VDD Turn-Off Voltage	V _{DDOFF}	V _{DD} Falling after Turn-on	5.25	5.5	5.75	V
Supply Current	I _{DD}	V _{DD} = 14V, after Turn-on		1	2	mA
Start Up Supply Current	I _{DDST}	V _{DD} = 14V, before Turn-on		25	45	μA
BD Current during Startup	I _{BDST}				1	μA
Internal Soft Startup Time				10		ms
Oscillator						
Switching Frequency	f _{SW}	100% V _{OUTCV} @ full load	80			kHz
		25% V _{OUTCV} @ full load	40			
Maximum Switching Frequency	F _{CLAMP}		85	100	110	kHz
Maximum Duty Cycle	D _{MAX}		65	75	85	%
Feedback						
Effective FB Voltage	V _{FB}		2.176	2.200	2.224	V
FB Leakage Current	I _{FBLK}				100	nA
Output Cable Resistance Compensation	D _{VCOMP}	No R _{CORD} between VDD and SW	0			%
		R _{CORD} = 300k	3			
		R _{CORD} = 150k	6			
		R _{CORD} = 75k	9			
		R _{CORD} = 33k	12			

ELECTRICAL CHARACTERISTICS CONT'D

($V_{DD} = 14V$, $V_{OUT} = 5V$, $L_P = 1.5mH$, $N_P = 140$, $N_S = 7$, $N_A = 19$, $T_A = 25^\circ C$, unless otherwise specified.)

PARAMETER	SYMBOL	TEST CONDITIONS	MIN	TYP	MAX	UNIT
Current Limit						
SW Current Limit Range	I_{LIM}		100		800	mA
CS Current Limit Threshold	V_{CSLIM}	$t_{OFF_DELAY} = 0$	380	396	412	mV
Leading Edge Blanking Time			200	300		ns
Driver Outputs						
Switch ON-Resistance	R_{ON}	$I_{SW} = 50mA$		1.6	3	Ω
SW Off Leakage Current		$V_{SW} = V_{DD} = 22V$			5	μA
Protection						
VDD Latch-Off Voltage	V_{DDOVP}		$V_{DDON} + 2$	$V_{DDON} + 3$	$V_{DDON} + 4$	V
Thermal Shutdown Temperature				135		$^\circ C$
Thermal Hysteresis				20		$^\circ C$
Line UVLO	I_{FBUVLO}			116		μA

FUNCTIONAL BLOCK DIAGRAM

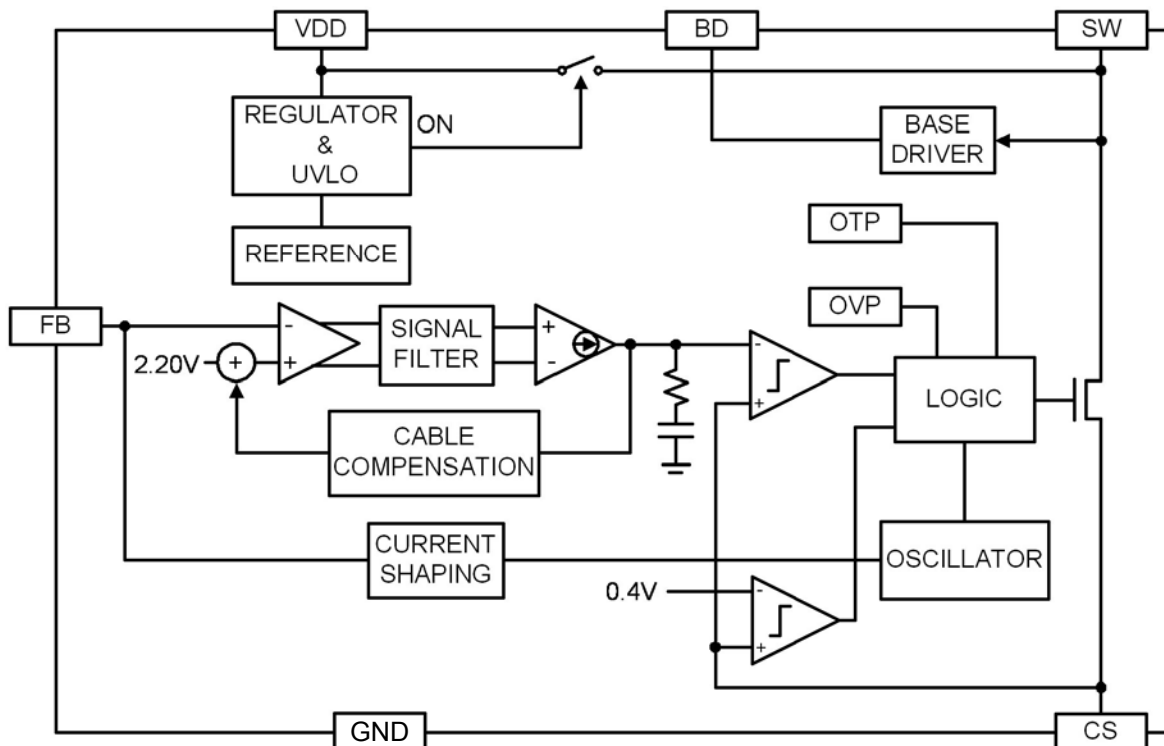

FUNCTIONAL DESCRIPTION

As shown in the *Functional Block Diagram*, to regulate the output voltage in CV (constant voltage) mode, the ACT366 compares the feedback voltage at FB pin to the internal reference and generates an error signal to the pre-amplifier. The error signal, after filtering out the switching transients and compensated with the internal compensation network, modulates the external NPN transistor peak current at CS pin with current mode PFWM (Pulse Frequency and Width Modulation) control. To regulate the output current in CC (constant current) mode, the oscillator frequency is modulated by the output voltage.

SW is a driver output that drives the emitter of an external high voltage NPN transistor. This base-emitter-drive method makes the drive circuit the most efficient.

Fast Startup

VDD is the power supply terminal for the ACT366. During startup, the ACT366 typically draws only 20µA supply current. The startup resistor from the rectified high voltage DC rail supplies current to the base of the NPN transistor. This results in an amplified emitter current to VDD through the SW pin via Active-Semi's proprietary fast-startup circuitry until it exceeds the V_{DDON} threshold 19V. At this point, the ACT366 enters internal startup mode with the peak current limit ramping up in 10ms. After switching starts, the output voltage begins to rise. The VDD bypass capacitor must supply the ACT366 internal circuitry and the NPN base drive until the output voltage is high enough to sustain VDD through the auxiliary winding. The V_{DDOFF} threshold is 5.5V; therefore, the voltage on the VDD capacitor must remain above 5.5V while the output is charging up.

Constant Voltage (CV) Mode Operation

In constant voltage operation, the ACT366 captures the auxiliary flyback signal at FB pin through a resistor divider network R5 and R6 in Figure 6. The signal at FB pin is pre-amplified against the internal reference voltage, and the secondary side output voltage is extracted based on Active-Semi's proprietary filter architecture.

This error signal is then amplified by the internal error amplifier. When the secondary output voltage is above regulation, the error amplifier output voltage decreases to reduce the switch current. When the secondary output voltage is below regulation, the error amplifier output voltage

increases to ramp up the switch current to bring the secondary output back to regulation. The output regulation voltage is determined by the following relationship:

$$V_{OUTCV} = 2.20V \times \left(1 + \frac{R_{FB1}}{R_{FB2}}\right) \times \frac{N_S}{N_A} - V_D \quad (1)$$

where R_{FB1} (R5) and R_{FB2} (R6) are top and bottom feedback resistor, N_S and N_A are numbers of transformer secondary and auxiliary turns, and V_D is the rectifier diode forward drop voltage at approximately 0.1A bias.

Standby (No Load) Mode

In no load standby mode, the ACT366 oscillator frequency is further reduced to a minimum frequency while the current pulse is reduced to a minimum level to minimize standby power. The actual minimum switching frequency is programmable with an output preload resistor.

Loop Compensation

The ACT366 integrates loop compensation circuitry for simplified application design, optimized transient response, and minimal external components.

Output Cable Resistance Compensation

The ACT366 provides programmable output cable resistance compensation during constant voltage regulation, monotonically adding an output voltage correction up to predetermined percentage at full power. There are four levels to program the output cable compensation by connecting a resistor (R10 in Figure 3) from the SW pin to VDD pin. The percentage at full power is programmable to be 3%, 6%, 9% or 12%, and by using a resistor value of 300k, 150k, 75k or 33k respectively. If there is no resistor connection, there is no cord compensation.

This feature allows for better output voltage accuracy by compensating for the output voltage droop due to the output cable resistance.

Constant Current (CC) Mode Operation

When the secondary output current reaches a level set by the internal current limiting circuit, the ACT366 enters current limit condition and causes the secondary output voltage to drop. As the output voltage decreases, so does the flyback voltage in a proportional manner. An internal current shaping circuitry adjusts the switching frequency based on the flyback voltage so that the transferred power remains proportional to the output voltage, resulting

FUNCTIONAL DESCRIPTION CONT'D

in a constant secondary side output current profile. The energy transferred to the output during each switching cycle is $\frac{1}{2}(L_P \times I_{LIM}^2) \times \eta$, where L_P is the transformer primary inductance, I_{LIM} is the primary peak current, and η is the conversion efficiency. From this formula, the constant output current can be derived:

$$I_{OUTCC} = \frac{1}{2} \times L_P \times \left(\frac{0.396V \times 0.9}{R_{CS}} \right)^2 \times \left(\frac{\eta \times f_{SW}}{V_{OUTCV}} \right) \quad (2)$$

where f_{SW} is the switching frequency and V_{OUTCV} is the nominal secondary output voltage.

The constant current operation typically extends down to lower than 40% of nominal output voltage regulation.

Primary Inductance Compensation

The ACT366 integrates a built-in proprietary (patent-pending) primary inductance compensation circuit to maintain constant current regulation despite variations in transformer manufacturing. The compensated range is $\pm 7\%$.

Primary Inductor Current Limit Compensation

The ACT366 integrates a primary inductor peak current limit compensation circuit to achieve constant input power over line and load ranges.

Protection

The ACT366 incorporates multiple protection functions including over-voltage, over-current and over-temperature.

Output Short Circuit Protection

When the secondary side output is short circuited, the ACT366 enters hiccup mode operation. In this condition, the VDD voltage drops below the V_{DDOFF} threshold and the auxiliary supply voltage collapses. This turns off the ACT366 and causes it to restart. This hiccup behavior continues until the short circuit is removed.

Output Over Voltage Protection

The ACT366 includes output over-voltage protection circuitry, which shuts down the IC when the output voltage is 40% above the normal regulation voltage for 4 consecutive switching cycles. The ACT366 enters hiccup mode when an output over voltage fault is detected.

Over Temperature Shutdown

The thermal shutdown circuitry detects the ACT366

die temperature. The typical over temperature threshold is 135°C with 20°C hysteresis. When the die temperature rises above this threshold the ACT366 is disabled until the die temperature falls by 20°C, at which point the ACT366 is re-enabled.

TYPICAL APPLICATION

Design Example

The design example below gives the procedure for a DCM flyback converter using the ACT366. Refer to Application Circuit in Figure 3, the design for an adapter application starts with the following specification:

Input Voltage Range	85VAC - 265VAC, 50/60Hz
Output Power, P_O	12W
Output Voltage, V_{OUTCV}	12V
Full Load Current, I_{OUTFL}	1A
OCP Current, I_{OUTMAX}	1.2A
Transformer Efficiency, η_{xfm}	0.89
System Efficiency CC, η_{system}	0.78
System Efficiency CV, η	0.79

The operation for the circuit shown in Figure 3 is as follows: the rectifier bridge D3 and the capacitor C1/C2 convert the AC line voltage to DC. This voltage supplies the primary winding of the transformer T1 and the startup resistor R7. The primary power current path is formed by the transformer's primary winding, the NPN transistor, the ACT366 internal MOSFET and the current sense resistor R9. The network consisting of capacitor C4 and diode D6 provides a VDD supply voltage for ACT366 from the auxiliary winding of the transformer. C4 is the decoupling capacitor of the supply voltage and energy storage component for startup. The diode D8 and the capacitor C5/C6 rectifies and filters the output voltage. The resistor divider consisting of R5 and R6 programs the output voltage.

The minimum and maximum DC input voltages can be calculated:

$$V_{INDCMIN} = \sqrt{2V_{ACMIN}^2 - \frac{2P_{OUT} \left(\frac{1}{2f_L} - t_c \right)}{\eta \times C_{IN}}}$$

$$= \sqrt{2 \times 85^2 - \frac{2 \times 12 \left(\frac{1}{2 \times 50} - 4.5ms \right)}{78\% \times 15 \times 10 \mu F}} \approx 90V \quad (3)$$

$$V_{INDCMAX} = \sqrt{2} \times V_{ACMAX} = \sqrt{2} \times 265 = 375V \quad (4)$$

TYPICAL APPLICATION CONT'D

where η is the estimated circuit efficiency, f_L is the line frequency, t_C is the estimated rectifier conduction time, C_{IN} is empirically selected to be $15\mu\text{F} + 10\mu\text{F}$ electrolytic capacitors based on the $2\mu\text{F}/\text{W}$ rule of thumb.

When the transistor is turned off, the voltage on the transistor's collector consists of the input voltage and the reflected voltage from the transformer's secondary winding. There is a ringing on the rising top edge of the flyback voltage due to the leakage inductance of the transformer. This ringing is clamped by a RCD network if it is used. Design this clamped voltage as 50V below the breakdown of the NPN transistor. The flyback voltage has to be considered with selection of the maximum reverse voltage rating of secondary rectifier diode. If a 100V Schottky diode is used, then the flyback voltage can be calculated:

$$V_{RO} = \frac{V_{INDCMAX} \times (V_{OUTCV} + V_{DS})}{V_{DREV} - V_{OUTCV}} = \frac{375 \times (12 + 0.5)}{100 \times 0.8 - 12} = 68.9\text{V} \quad (5)$$

where V_{DS} is the Schottky diode forward voltage, V_{DREV} is the maximum reverse voltage rating of the diode and V_{OUTCV} is the output voltage.

The maximum duty cycle is set to be 50% at low line voltage $85V_{AC}$ and the circuit efficiency is estimated to be 78%. Then the full load input current is:

$$I_{IN} = \frac{V_{OUTCV} \times I_{OUTPL}}{V_{INDCMIN} \times \eta} = \frac{12 \times 1}{90 \times 78\%} = 170.9\text{mA} \quad (6)$$

The maximum input primary peak current at full load base on duty of 50%:

$$I_{PK} = \frac{2 \times I_{IN}}{D} = \frac{2 \times 170.9}{50\%} = 683\text{mA} \quad (7)$$

The primary inductance of the transformer:

$$L_P = \frac{V_{INDCMIN} \times D}{I_{PK} \times f_{SW}} = \frac{90 \times 50\%}{683\text{mA} \times 75\text{kHz}} \approx 0.87\text{mH} \quad (8)$$

ACT366 needs to work in DCM in all conditions, thus N_P/N_S should meet

$$\frac{L_P \times I_{PK}}{V_{INDCMIN}} + \frac{L_P \times I_{PK}}{(V_{OUTCV} + V_{DS}) \times \frac{N_P}{N_S}} < \frac{0.9}{f_{SW}} \Rightarrow \frac{N_P}{N_S} > 8 \quad (9)$$

The auxiliary to secondary turns ratio N_A/N_S :

$$\frac{N_A}{N_S} = \frac{V_{DD} + V_{DA} + V_R}{V_{OUTCV} + V_{DS} + V_{CORD}} = \frac{13 + 0.25 + 1}{12 + 0.3 + 0.35} \approx 1.1 \quad (10)$$

Where V_{DA} is diode forward voltage of the auxiliary side and V_R is the resistor voltage.

An EPC17 transformer gapped core with an effective inductance A_{LE} of $80\text{nH}/T^2$ is selected. The number of turns of the primary winding is:

$$N_P = \sqrt{\frac{L_P}{A_{LE}}} = \sqrt{\frac{0.87\text{mH}}{80\text{nH}/T^2}} = 110 \quad (11)$$

The number of turns of secondary and auxiliary windings can be derived when $N_P/N_S=7$:

$$N_S = \frac{N_S}{N_P} \times N_P = \frac{1}{7} \times 110 \approx 14 \quad (12)$$

$$N_A = \frac{N_A}{N_S} \times N_S = 1.1 \times 14 = 16 \quad (13)$$

The current sense resistance (R_{CS}) determines the current limit value based on the following equation:

$$R_{CS} = \frac{0.9 \times V_{CSLIM}}{\sqrt{(I_{OUTFL} + I_{OUTMAX}) \times (V_{OUT} + V_{DS})}} = \frac{0.9 \times 0.396}{\sqrt{(1.0 + 1.2) \times 123}} = 0.5R \quad (14)$$

The voltage feedback resistors are selected according to below equation:

$$R_{FB1} = \frac{N_A}{N_P} \times \frac{L_P}{R_{CS}} \times K = \frac{16}{110} \times \frac{0.87}{0.5} \times 230000 \approx 59\text{k} \quad (15)$$

In actual application 59K is selected.

Where K is IC constant and $K = 230000$.

$$R_{FB2} = \frac{V_{FB}}{(V_{OUTCV} + V_{DS}) \times \frac{N_A}{N_S} - V_{FB}} R_{FB1} \quad (16)$$

$$= \frac{2.20}{(12 + 0.45) \times 1.1 - 2.20} \times 59\text{K} \approx 11\text{k}$$

When selecting the output capacitor, a low ESR electrolytic capacitor is recommended to minimize ripple from the current ripple. The approximate equation for the output capacitance value is given by:

$$C_{OUT} = \frac{I_{OUTCC} \times D}{f_{SW} \times \Delta V_{RIPPLE}} = \frac{1.2 \times 0.5}{60\text{kHz} \times 50\text{mV}} = 200\mu\text{F} \quad (17)$$

A $600\mu\text{F}$ electrolytic capacitor is used to keep the ripple small.

PCB Layout Guideline

Good PCB layout is critical to have optimal performance. Decoupling capacitor (C_4), current sense resistor (R_9) and feedback resistor (R_5/R_6) should be placed close to V_{DD} , CS and FB pins respectively. There are two main power path loops. One is formed by C_1/C_2 , primary winding, NPN transistor and the ACT366. The other is the secondary winding, rectifier D8 and output capacitors (C_5, C_6). Keep these loop areas as small as possible. Connect high current ground returns,

TYPICAL APPLICATION CONT'D

the input capacitor ground lead, and the ACT366 G pin to a single point (star ground configuration).

V_{FB} Sampling Waveforms

ACT366 senses the output voltage information through the V_{FB} waveforms. Proper V_{FB} waveforms are required for IC to operate in a stable status. To avoid mis-sampling, 1.0 μ s blanking time is added to blank the ringing period due to the leakage inductance and the circuit parasitic capacitance.

Figure 2 is the recommended V_{FB} waveform to guarantee the correct sampling point so that the output information can be sent back into the IC to do the appropriate control.

Figure 2:

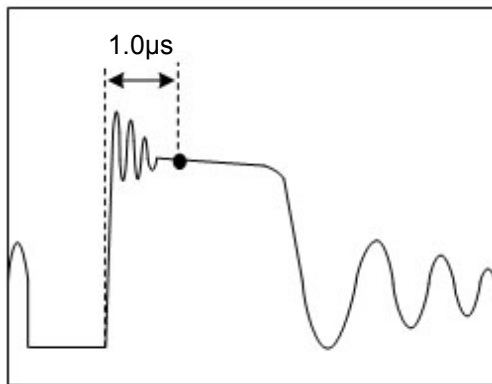

Figure 3:
Universal VAC Input, 12V/1A Output Adapter

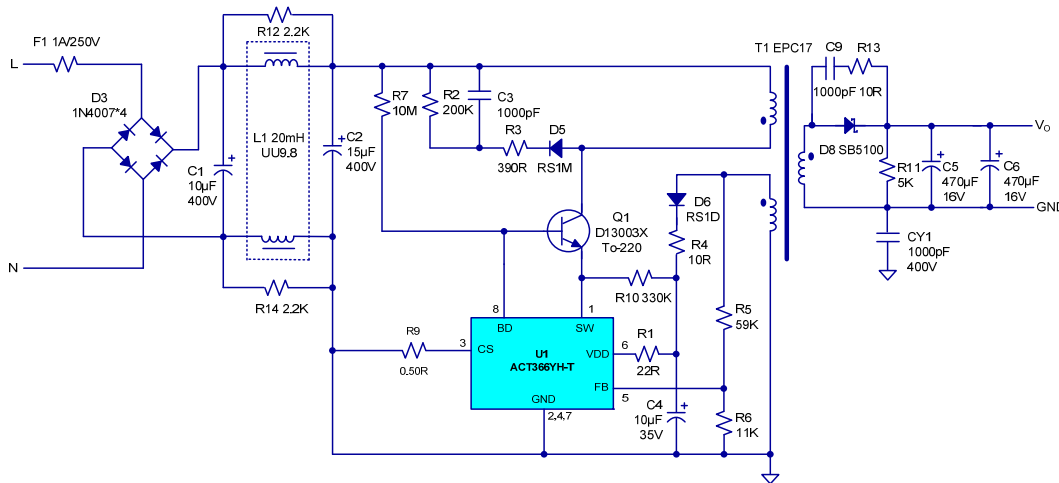
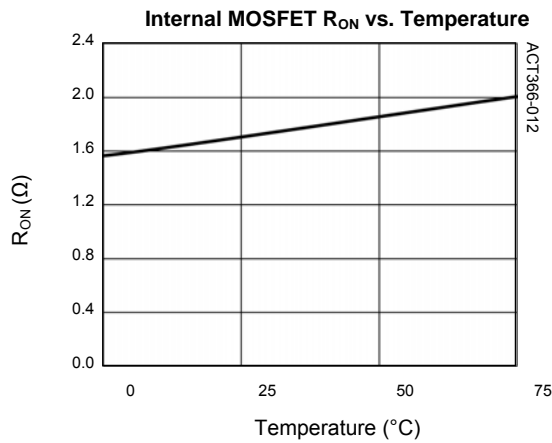
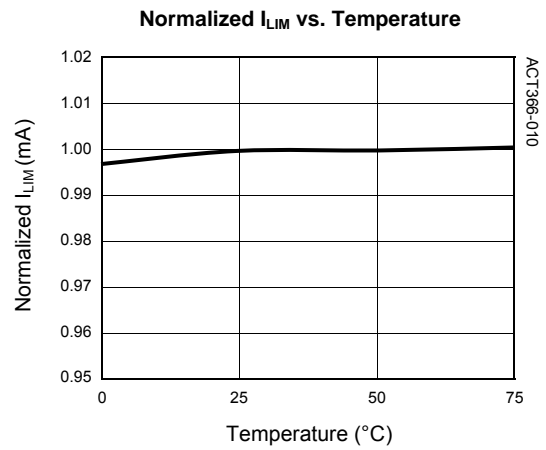
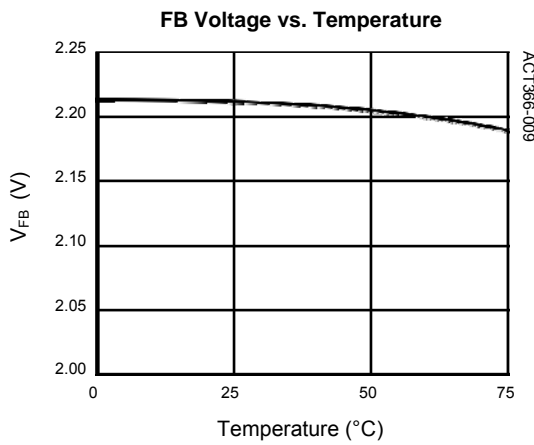
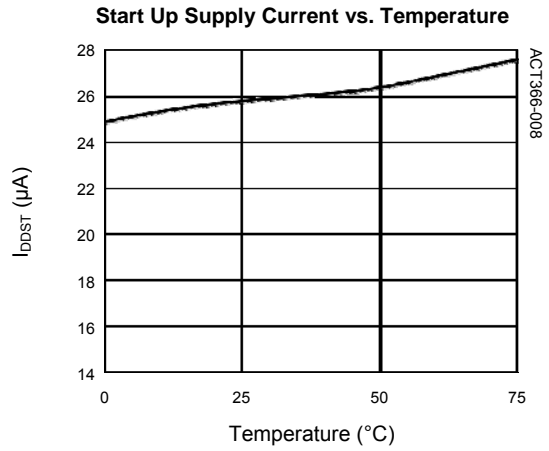
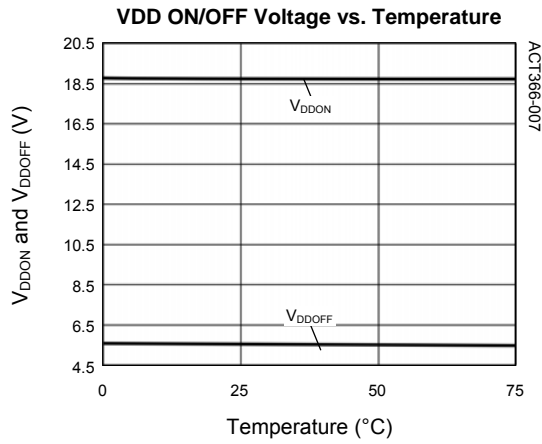

Table 2:
ACT366 Bill of Materials

ITEM	REFERENCE	DESCRIPTION	QTY	MANUFACTURER
1	C1	Capacitor, Electrolytic, 10µF/400V, 10×12mm	1	KSC
2	C2	Capacitor, Electrolytic, 15µF/400V, 10×12mm	1	KSC
2	C3	Capacitor, Ceramic, 1000pF/500V, 1206, SMD	1	POE
3	C4	Capacitor, Electrolytic, 10µF/35V, 1206, SMD	1	KSC
4	C5	Capacitor, Electrolytic, 470µF/16V, 8 ×12mm	1	KSC
5	C6	Capacitor, Electrolytic, 470µF/16V, 8 ×12mm	1	KSC
6	C9	Capacitor, Ceramic, 1000pF/50V, 0805, SMD	1	POE
7	CY1	Safety Y1, Capacitor, 1000pF/400V, Dip	1	UXT
8	D1-D4	Diode, Rectifier, 1000V/1A, 1N4007, DO-41	4	Good-Ark
9	D5, D6	Diode, Ultra Fast, FR107, 1000V/1.0A, DO-41	2	Good-Ark
10	D8	Diode, Schottky, 100V/5A, SB5100, DO-210AD	1	Good-Ark
11	L1	Common choke mode, UU9.8, 20mH, DIP	1	
12	Q1	Transistor, NPN, 700V, 1.5A, D13003, TO-220	1	Huawei
13	F1	Fuse: 1A 250V 3.6*10mm With Pigtail, ceramic tube	1	walter
14	R1	Chip Resistor, 22Ω, 0805, 5%	1	TY-OHM
15	R2	Chip Resistor, 200k, 1206, 5%	1	TY-OHM
16	R3	Chip Resistor, 390Ω, 1206, 5%	1	TY-OHM
17	R4	Chip Resistor, 10Ω, 0805, 5%	1	TY-OHM
18	R5	Chip Resistor, 59k, 0805, 1%	1	TY-OHM
19	R6	Chip Resistor, 11k, 0805, 1%	1	TY-OHM
20	R7	Chip Resistor, 10mΩ, 1206, 5%	1	TY-OHM
21	R9	Chip Resistor, 0.5Ω, 1206, 1%	1	TY-OHM
22	R10	Chip Resistor, 330k, 0805, 5%	1	TY-OHM
23	R11	Chip Resistor, 5k, 0805, 5%	1	TY-OHM
24	R12, R14	Chip Resistor, 2.2K, 0805, 5%	2	TY-OHM
25	R13	Chip Resistor, 10Ω, 0805, 5%	1	TY-OHM
26	T1	Transformer, L _p = 0.9mH±7%, EPC17	1	
27	U1	IC, ACT366YH-T, SOP-8/EP	1	Active-Semi

TYPICAL PERFORMANCE CHARACTERISTICS CONT'D

(Circuit of Figure 6, unless otherwise specified.)



PACKAGE OUTLINE

SOP-8/EP PACKAGE OUTLINE AND DIMENSIONS

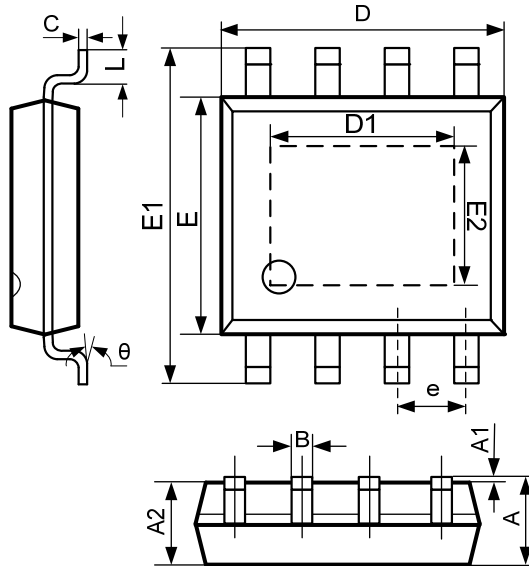

SYMBOL	DIMENSION IN MILLIMETERS		DIMENSION IN INCHES	
	MIN	MAX	MIN	MAX
A	1.350	1.700	0.053	0.067
A1	0.000	0.100	0.000	0.004
A2	1.350	1.550	0.053	0.061
B	0.330	0.510	0.013	0.020
C	0.190	0.250	0.007	0.010
D	4.700	5.100	0.185	0.201
D1	3.202	3.402	0.126	0.134
E	3.800	4.000	0.150	0.157
E1	5.800	6.300	0.228	0.248
E2	2.313	2.513	0.091	0.099
e	1.270 TYP		0.050 TYP	
L	0.400	1.270	0.016	0.050
theta	0°	8°	0°	8°

Active-Semi, Inc. reserves the right to modify the circuitry or specifications without notice. Users should evaluate each product to make sure that it is suitable for their applications. Active-Semi products are not intended or authorized for use as critical components in life-support devices or systems. Active-Semi, Inc. does not assume any liability arising out of the use of any product or circuit described in this datasheet, nor does it convey any patent license.

Active-Semi and its logo are trademarks of Active-Semi, Inc. For more information on this and other products, contact sales@active-semi.com or visit <http://www.active-semi.com>.

 is a registered trademark of Active-Semi.