

PART NAME

COMPUCAB

PART No.

SC-13101

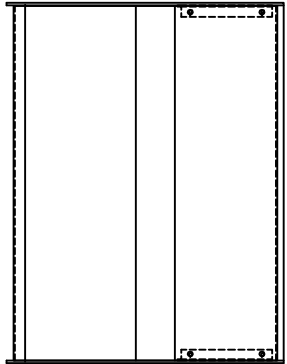

TOP VIEW

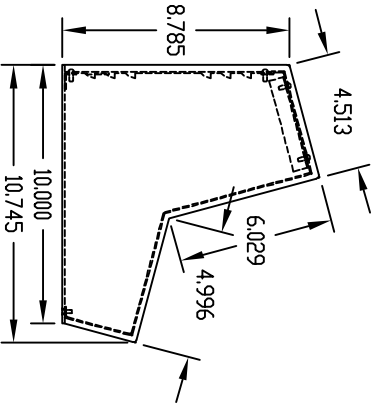

LEFT SIDE VIEW

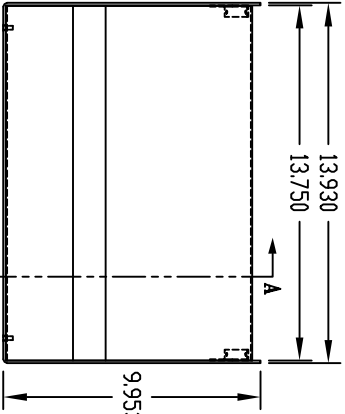

FRONT VIEW

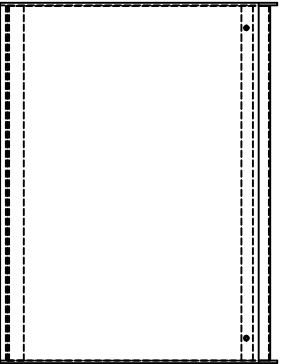

BOTTOM VIEW

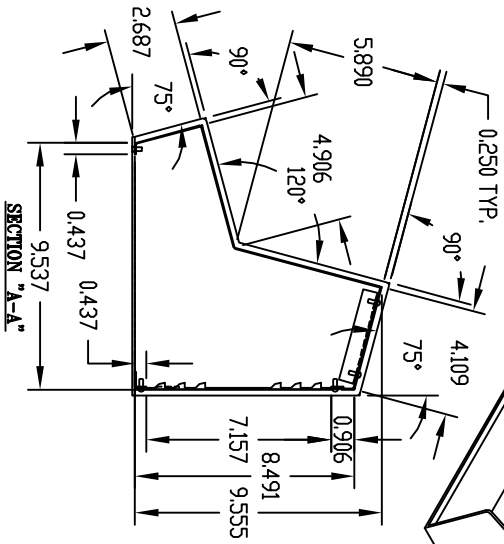
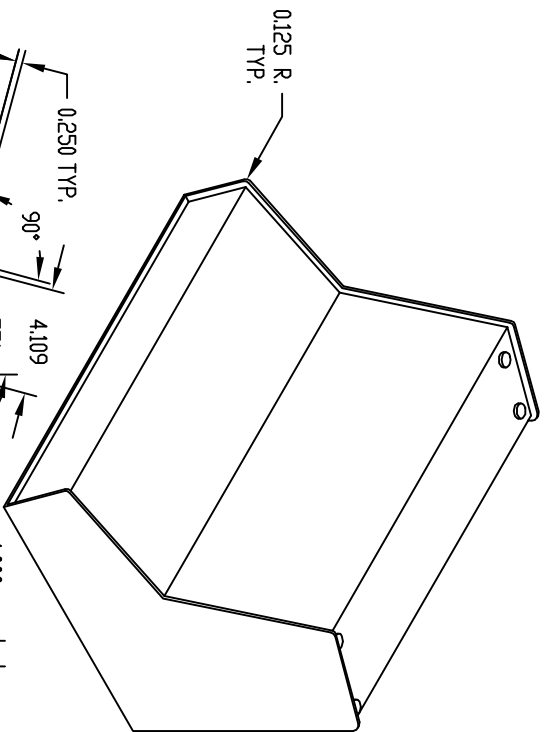

SECTION "A-A"

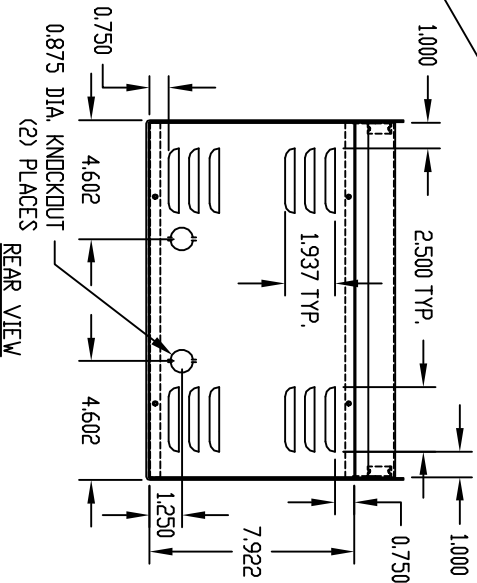

REAR VIEW

MATERIAL:

BASE _____ 0090 THK. ALUMINUM
 COVER & BACK PANEL _____ 0050 THK. ALUMINUM

FINISH:

BASE _____ BLACK TEXTURED
 COVER & BACK PANEL _____ WHITE (PREPAINTED)
 FEET _____ BLACK

ASSEMBLED WITH TEN (10) #6-32 x 3/8 LG. SCREWS.
 SUPPLIED WITH FOUR (4) SELF-ADHESIVE FEET.