

BODY

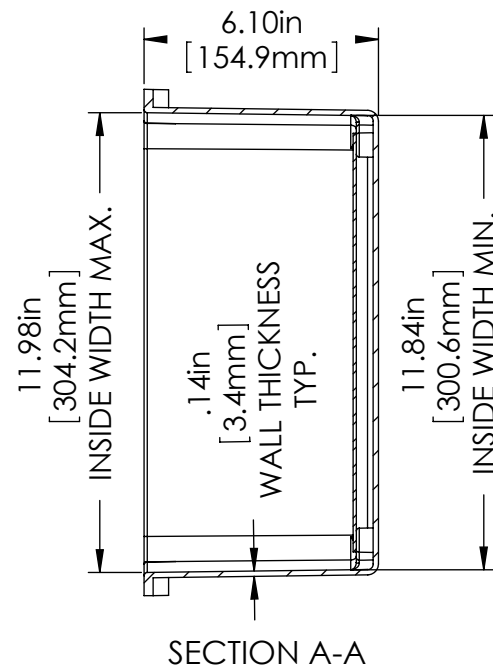

COVER

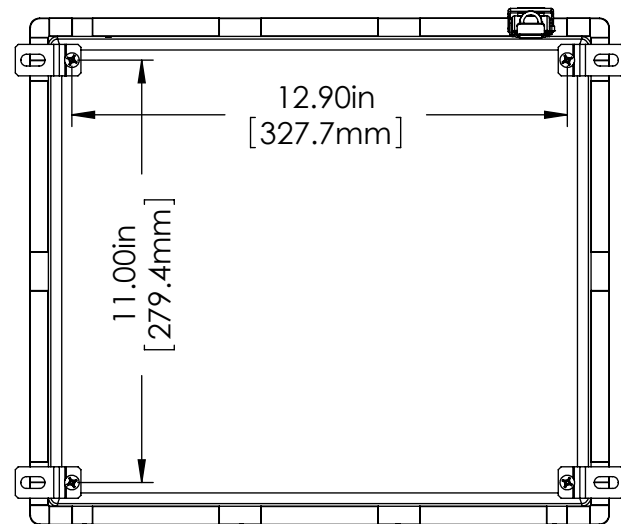
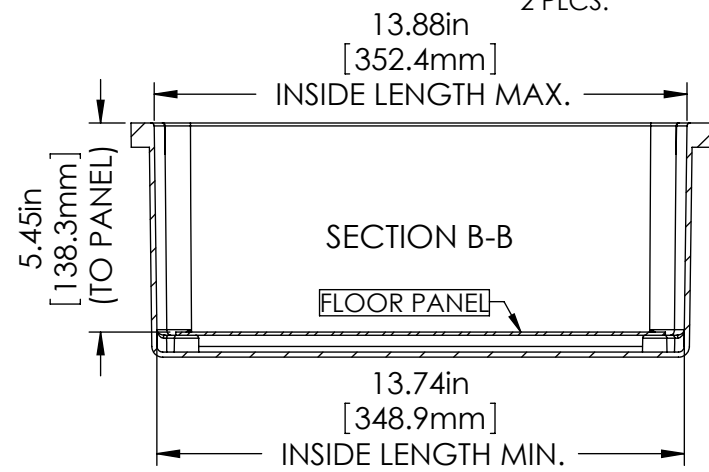
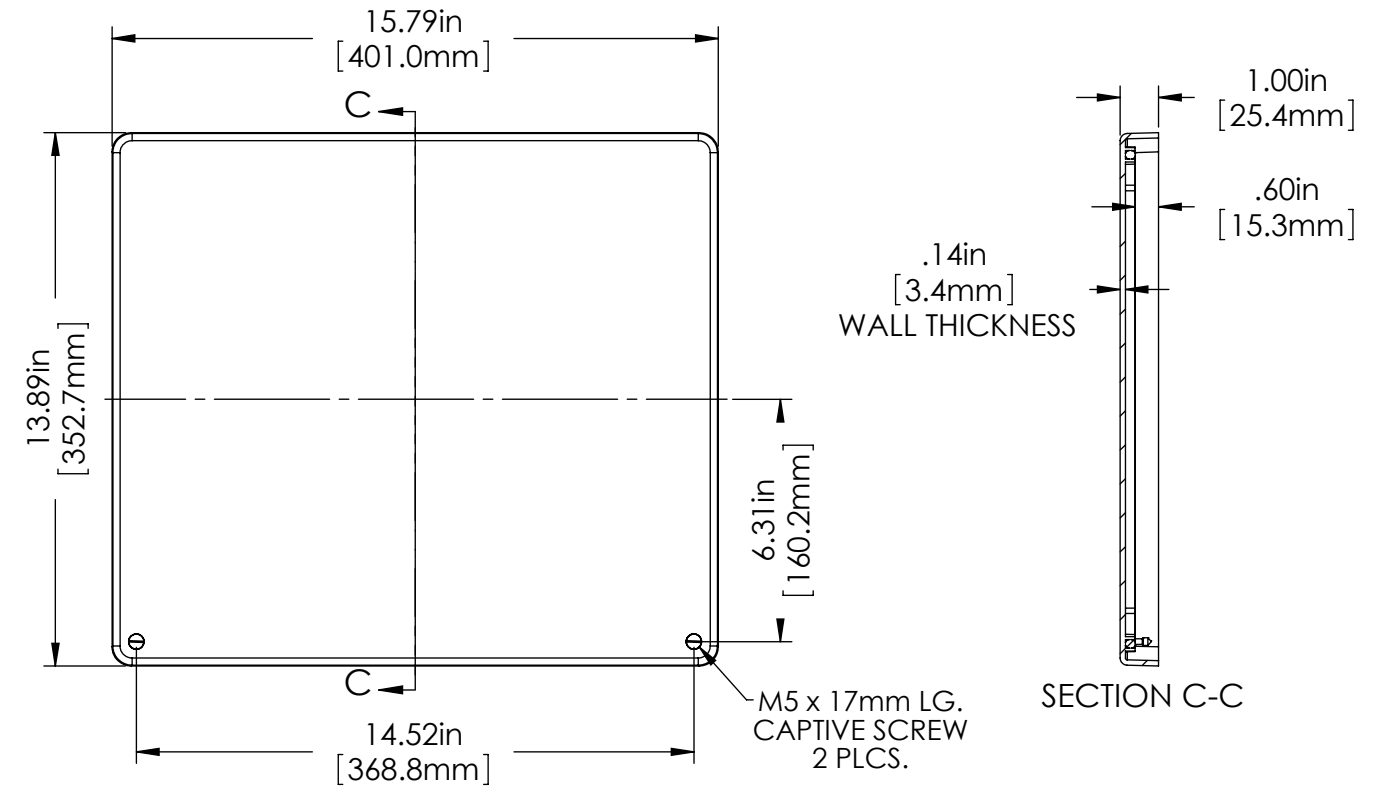

ASSEMBLY

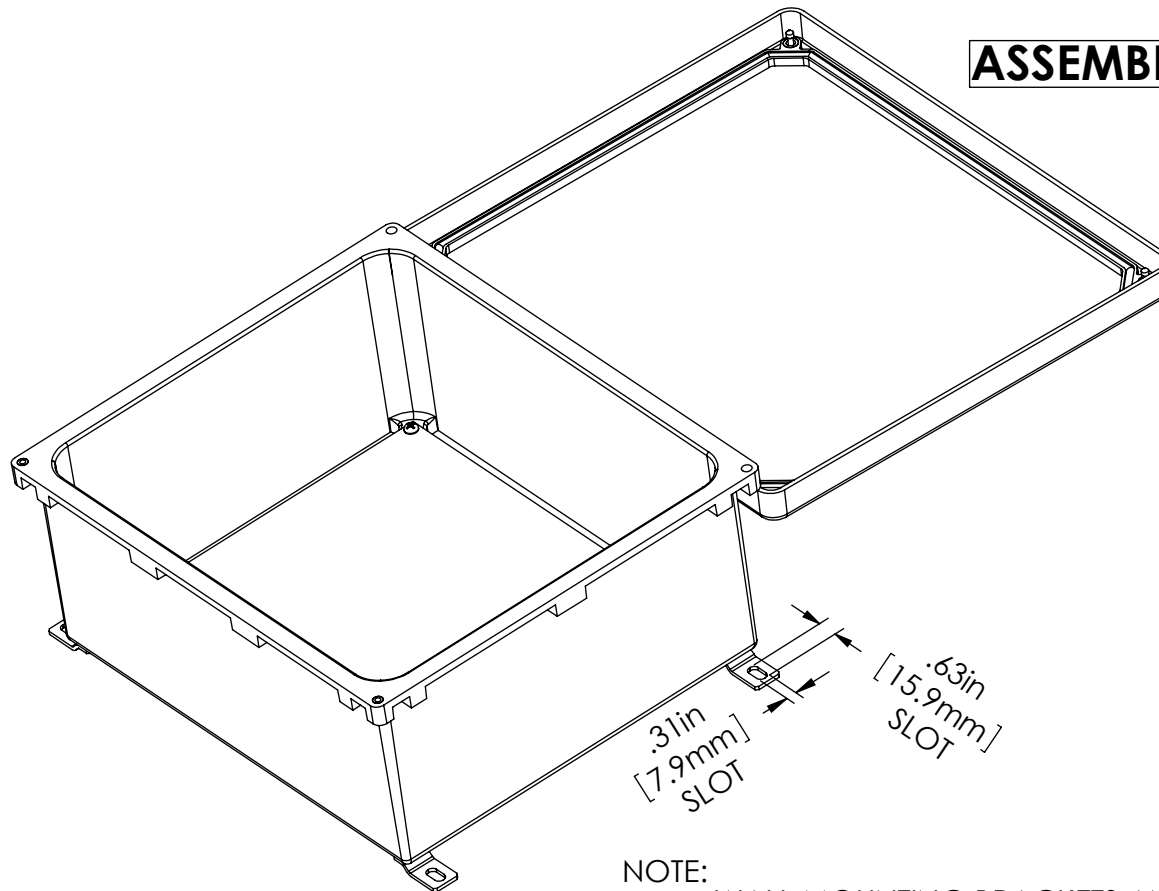

NOTE: WALL MOUNTING BRACKETS AND SCREWS SUPPLIED - UNASSEMBLED.

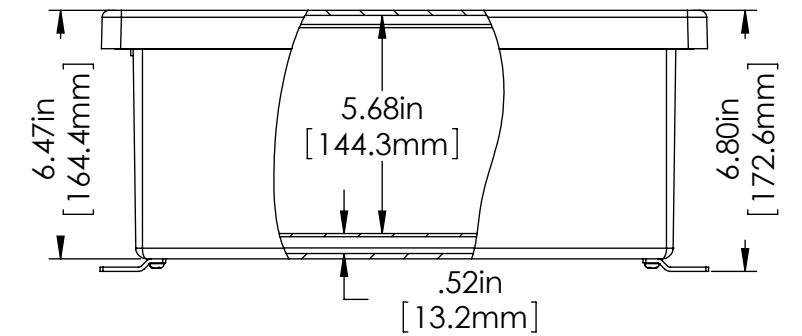

TOLERANCES: ±.02" (0.5mm) [UNLESS OTHERWISE SPECIFIED]

MATERIAL:
 BODY & COVER - FIBERGLASS REINFORCED POLYESTER (SMC)
 PANEL - 14 GA. (2mm) THK. COLD ROLLED STEEL
 MOUNTING BRACKETS - 12 GA. (2.5mm) 304 STAINLESS STEEL
 HINGE - 18 GA. (1.2mm) THK. 304 STAINLESS STEEL
 GASKET - SILICONE SPONGE

FINISH:
 BODY & COVER - LIGHT GREY
 PANEL - WHITE POLYESTER POWDER COAT
 MOUNTING BRACKETS & HINGE - NATURAL