

**BODY**

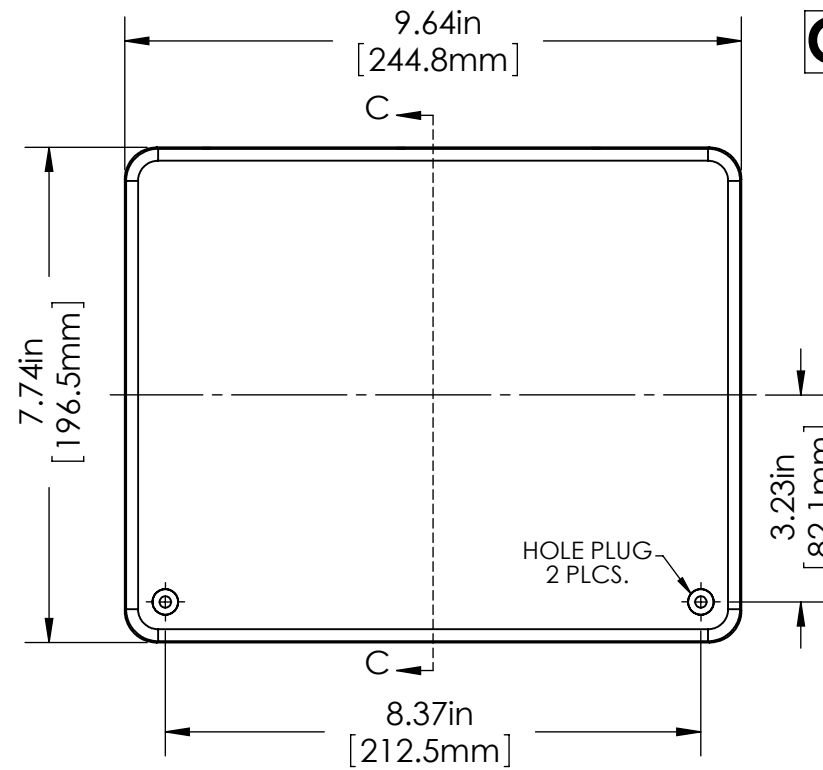

**COVER**

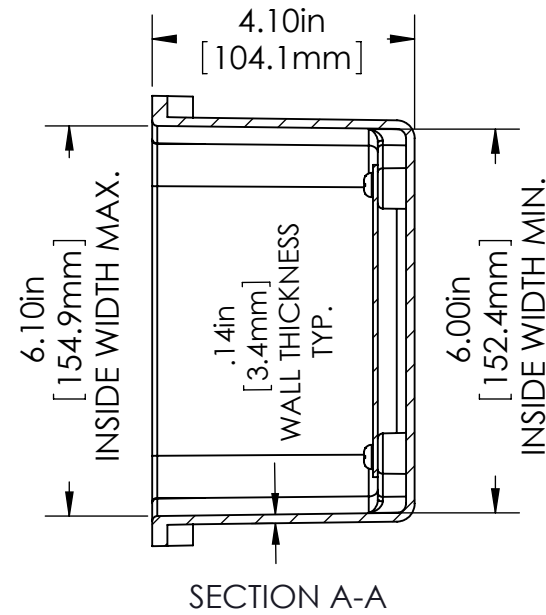
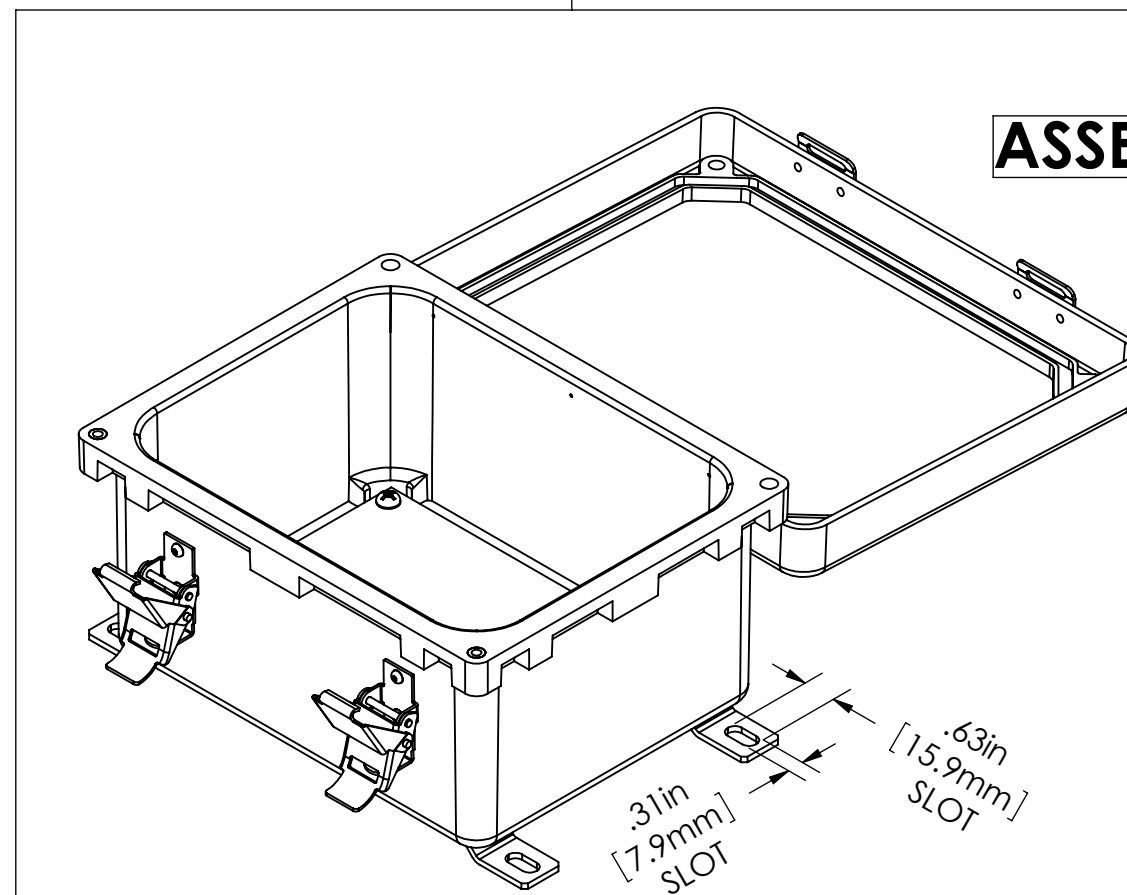
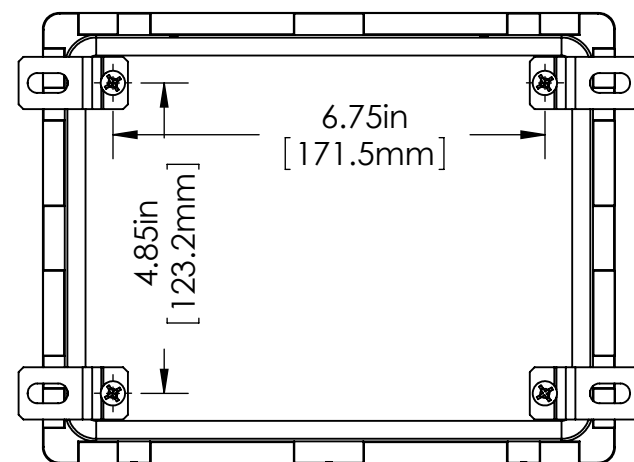
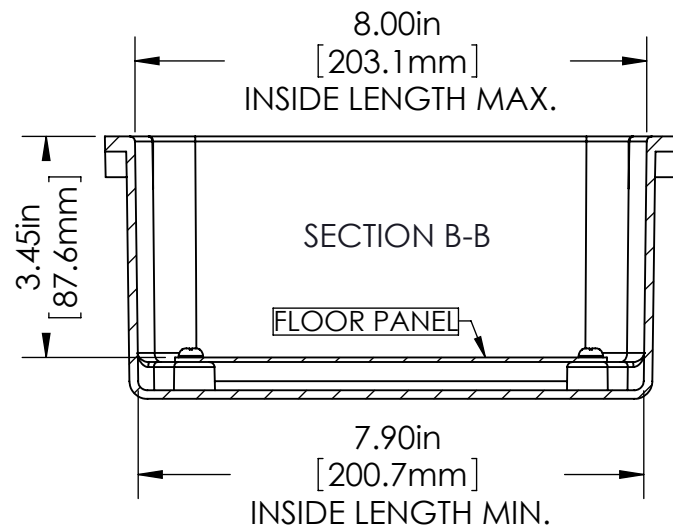
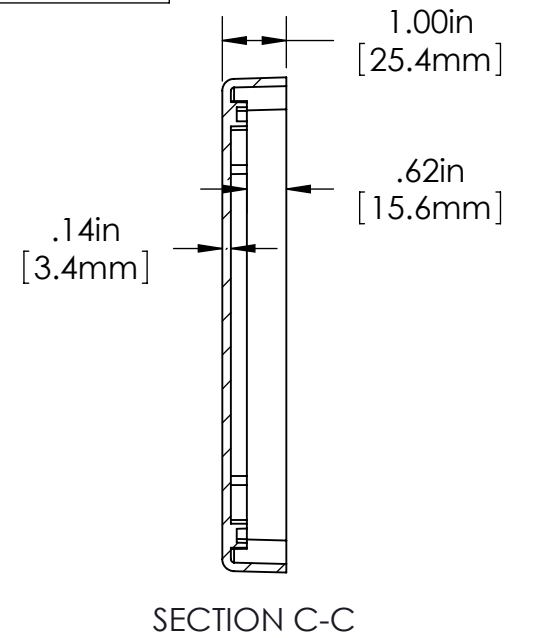

**ASSEMBLY**

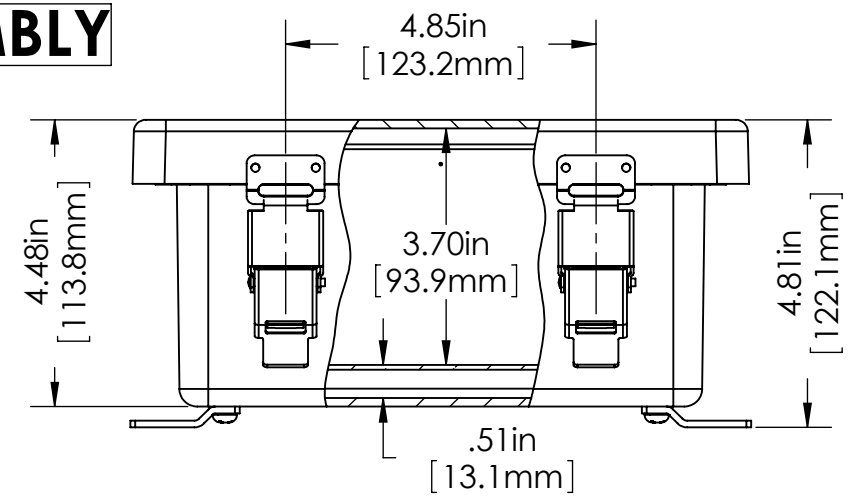

**TOLERANCES:** ±.02" (0.5mm) [UNLESS OTHERWISE SPECIFIED]

**MATERIAL:**  
 BODY & COVER - FIBERGLASS REINFORCED POLYESTER (SMC)  
 PANEL - 14 GA. (2mm) THK. COLD ROLLED STEEL  
 MOUNTING BRACKETS - 12 GA. (2.5mm) 304 STAINLESS STEEL  
 HINGE - 18 GA. (1.2mm) THK. 304 STAINLESS STEEL  
 LATCH - 17 GA. (1.3mm) THK. STAINLESS STEEL  
 GASKET - SILICONE SPONGE

**FINISH:**  
 BODY & COVER - LIGHT GREY  
 PANEL - WHITE POLYESTER POWDER COAT  
 MOUNTING BRACKETS & HINGE - NATURAL

NOTE:  
 WALL MOUNTING BRACKETS AND  
 SCREWS SUPPLIED - UNASSEMBLED.