

PART NAME

NEMA 4X ENCLOSURE

PART No.

PN-1330, PN-1330-C AND PN-1330-DG

REV. DATE

11-17-08

INDUSTRY STANDARDS:

- POLYCARBONATE (LIGHT GRAY AND CLEAR)
- UL94-HB FLAMMABILITY RATING (UL FILE #E41613)
- UV STABILIZED
- SERVICE TEMPERATURE RANGE: -40°C TO +120°C
- ABS (DARK GRAY)
- UL94-HB FLAMMABILITY RATING (UL FILE #E56070)
- SERVICE TEMPERATURE RANGE: -40°C TO +80°C

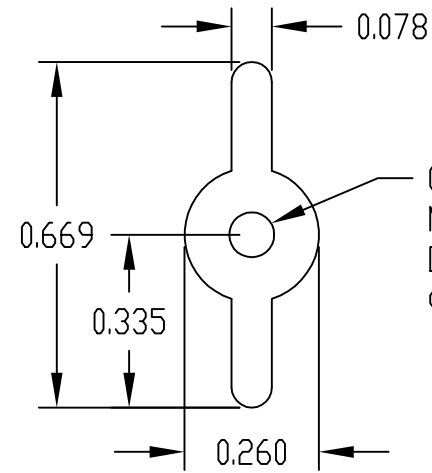

0.090 DIA. HOLE x 0.156 DEEP
MOUNTING BOSSES USE EITHER M2.5 METRIC
OR #4 STD. SHEET METAL SCREWS x 0.188 LG.
(NOT SUPPLIED)

DETAIL "C"
(2 PLACES)

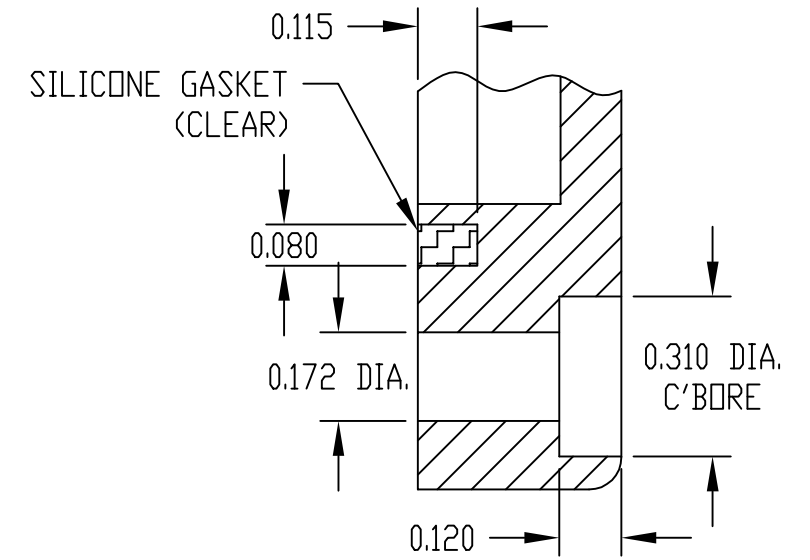

DETAIL "D"

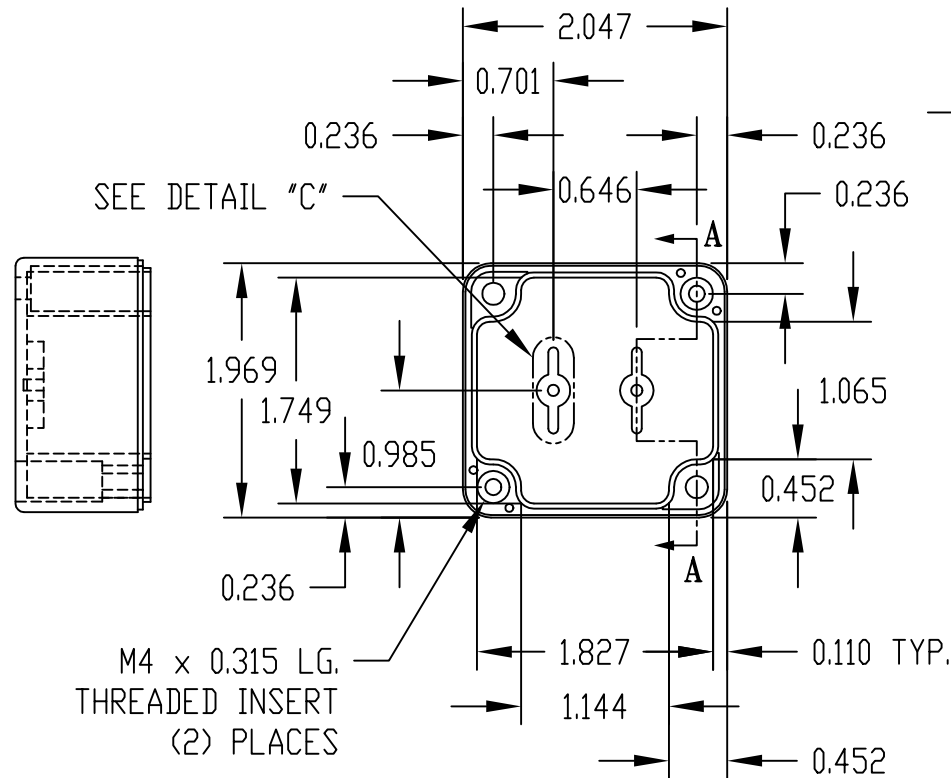

M4 x 0.315 LG. THREADED INSERT (2) PLACES

BODY

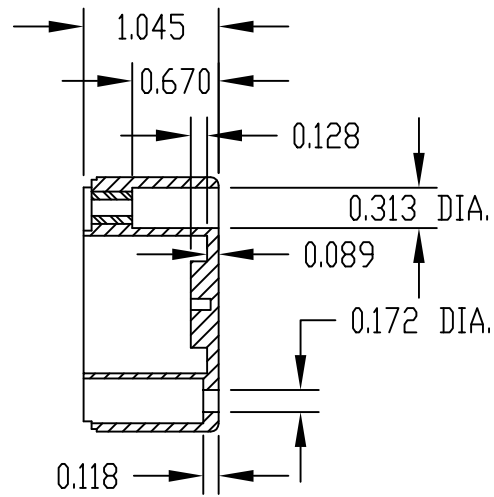

SECTION "A-A"

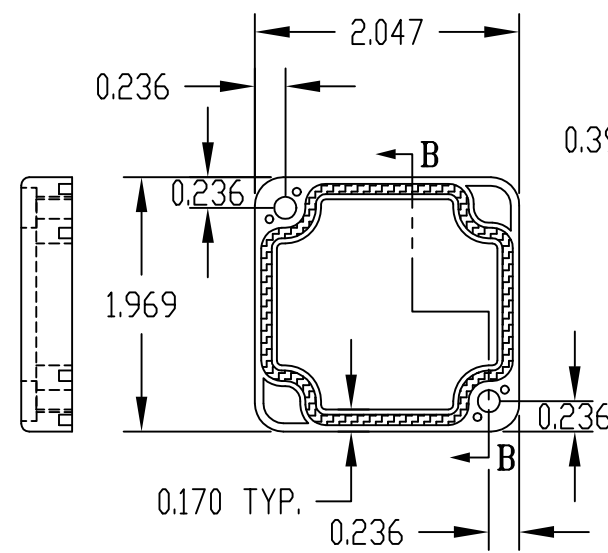

COVER

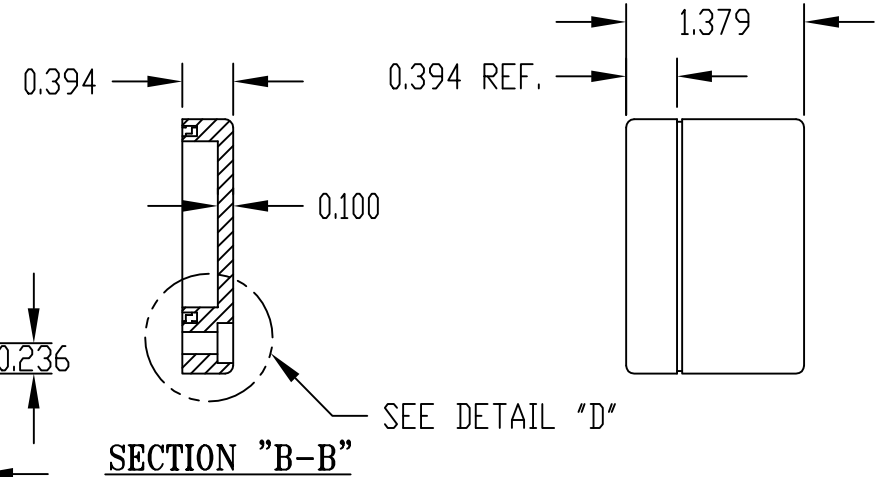

SECTION "B-B"

SEE DETAIL "D"

NOTE: ALL DIMENSIONS HAVE ±0.015 TOLERANCE UNLESS OTHERWISE SPECIFIED.

PART NUMBER	MATERIAL		FINISH		HARDWARE KIT
	BODY	COVER	BODY	COVER	
PN-1330	POLYCARBONATE		LIGHT GRAY		KIT CONTAINS (2) M4 x 20mm (0.787") LG. SCREWS FOR ASSEMBLY
PN-1330-C	POLYCARBONATE		LIGHT GRAY	CLEAR	
PN-1330-DG	HIGH-IMPACT ABS		DARK GRAY		