

PART NAME

NEMA 4X ENCLOSURE

PART No.

PN-1336, PN-1336-C AND PN-1336-DG

REV. DATE

11-17-08

INDUSTRY STANDARDS:

- POLYCARBONATE (LIGHT GRAY AND CLEAR)
- UL94-HB FLAMMABILITY RATING (UL FILE #E41613)
- UV STABILIZED
- SERVICE TEMPERATURE RANGE: -40°C TO +120°C
- ABS (DARK GRAY)
- UL94-HB FLAMMABILITY RATING (UL FILE #E56070)
- SERVICE TEMPERATURE RANGE: -40°C TO +80°C

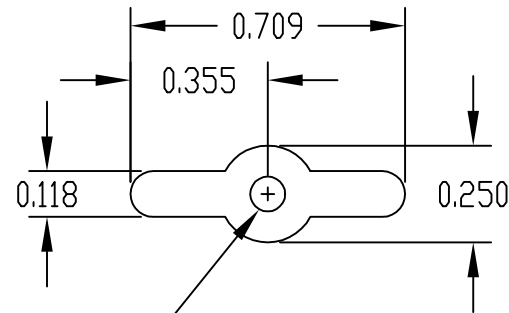

0.090 DIA. HOLE x 0.203 DEEP
MOUNTING BOSSES USE EITHER
M2.5 METRIC OR #4 STD. SHEET
METAL SCREWS x 0.188 LG.
(NOT SUPPLIED)

DETAIL "C"
(4) PLACES

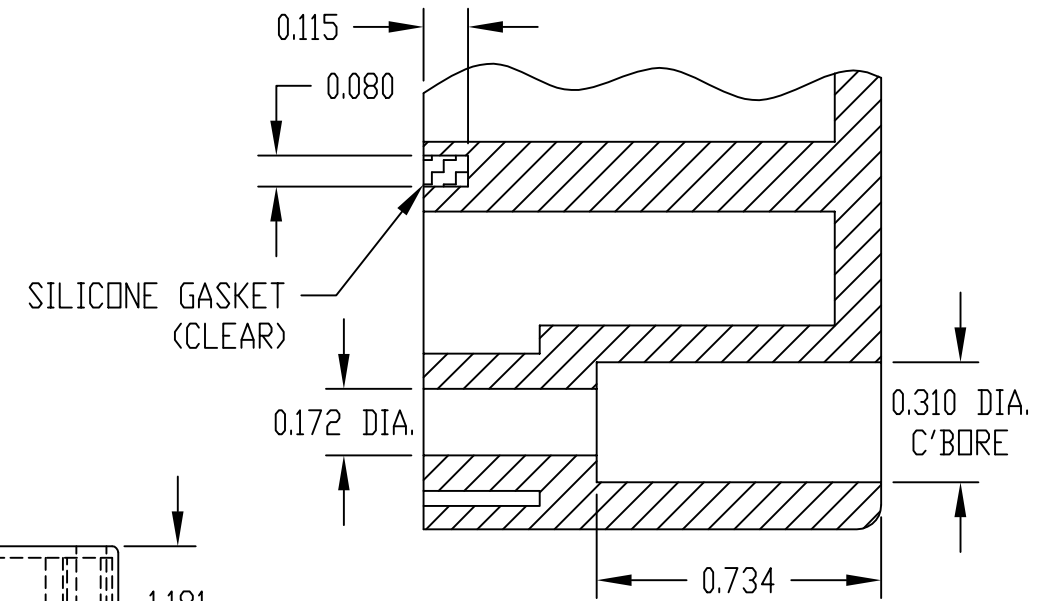

SILICONE GASKET
(CLEAR)

DETAIL "D"

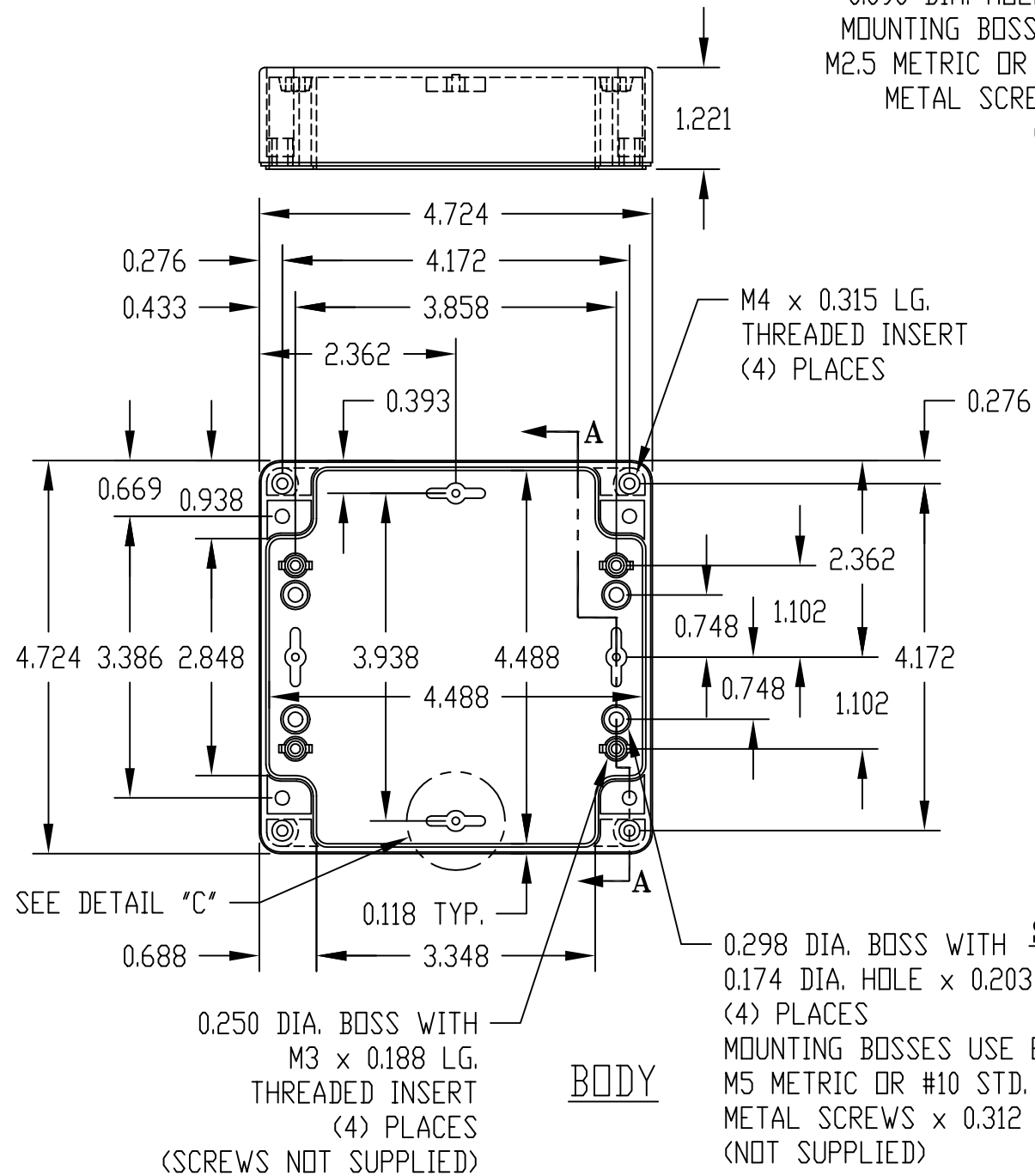

SEE DETAIL "C"

BODY

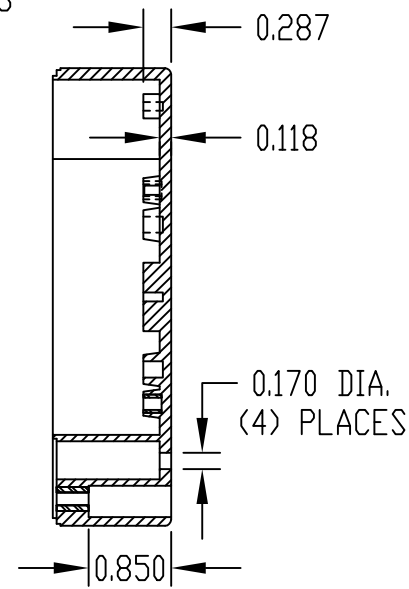

SECTION "A-A"

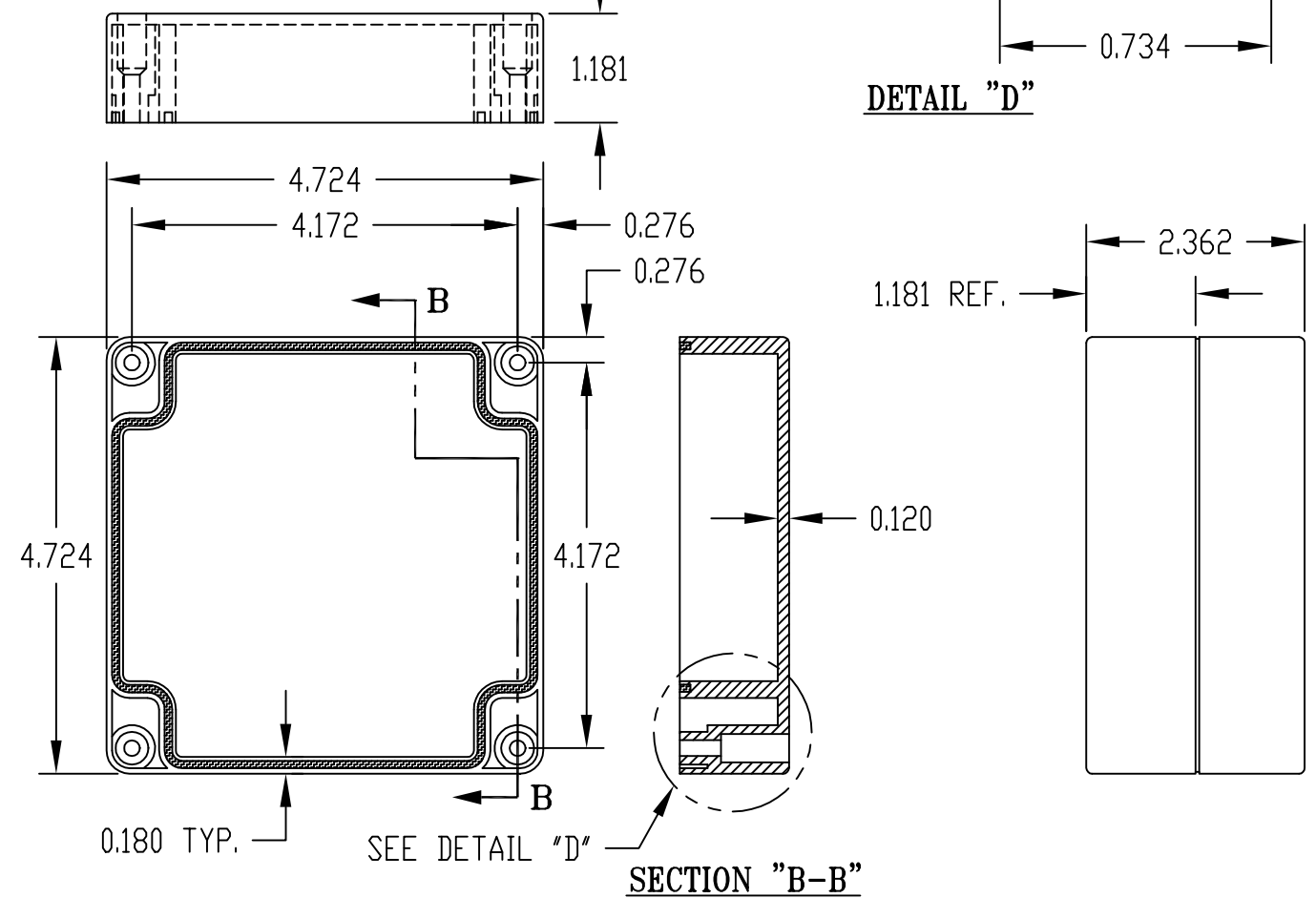

COVER

SECTION "B-B"

NOTE: ALL DIMENSIONS HAVE ±0.015 TOLERANCE UNLESS OTHERWISE SPECIFIED.

PART NUMBER	MATERIAL		FINISH		HARDWARE KIT
	BODY	COVER	BODY	COVER	
PN-1336	POLYCARBONATE		LIGHT GRAY		KIT CONTAINS (4) M4 x 20mm (0.787") LG. SCREWS FOR ASSEMBLY
PN-1336-C	POLYCARBONATE		LIGHT GRAY	CLEAR	
PN-1336-DG	HIGH-IMPACT ABS		DARK GRAY		