

PART NAME

NEMA 4X ENCLOSURE

PART No.

PN-1339, PN-1339-C AND PN-1339-DG

REV. DATE

11-17-08

INDUSTRY STANDARDS:

- POLYCARBONATE (LIGHT GRAY AND CLEAR)
- UL94-HB FLAMMABILITY RATING (UL FILE #E41613)
- UV STABILIZED
- SERVICE TEMPERATURE RANGE: -40°C TO +120°C
- ABS (DARK GRAY)
- UL94-HB FLAMMABILITY RATING (UL FILE #E56070)
- SERVICE TEMPERATURE RANGE: -40°C TO +80°C

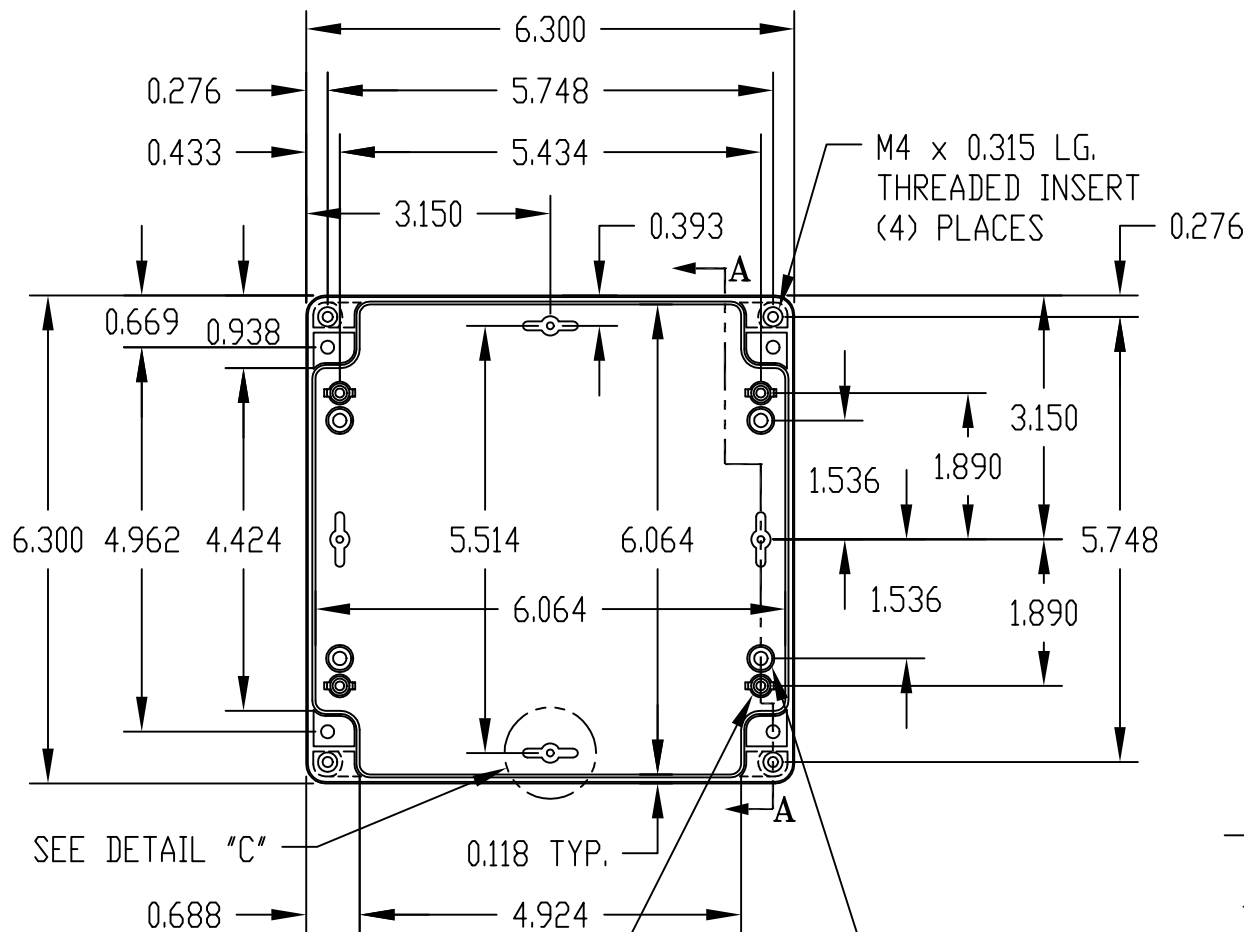
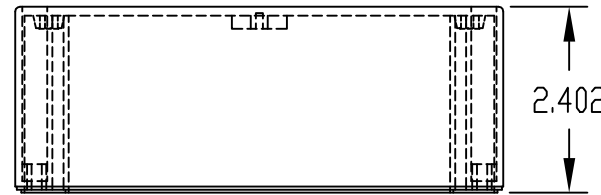

**BODY**

0.250 DIA. BOSS WITH M3 x 0.188 LG. THREADED INSERT (4) PLACES (SCREWS NOT SUPPLIED)

0.298 DIA. BOSS WITH 0.174 DIA. HOLE x 0.203 DEEP (4) PLACES MOUNTING BOSSES USE EITHER M5 METRIC OR #10 STD. SHEET METAL SCREWS x 0.312 LG. (NOT SUPPLIED)

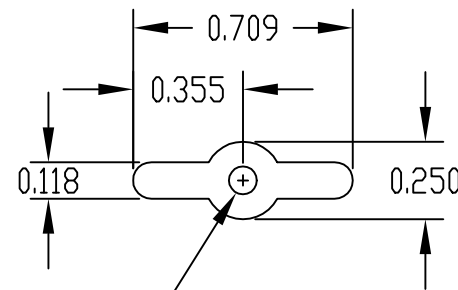

0.090 DIA. HOLE x 0.203 DEEP MOUNTING BOSSES USE EITHER M2.5 METRIC OR #4 STD. SHEET METAL SCREWS x 0.188 LG. (NOT SUPPLIED)

**DETAIL "C"**  
(4) PLACES

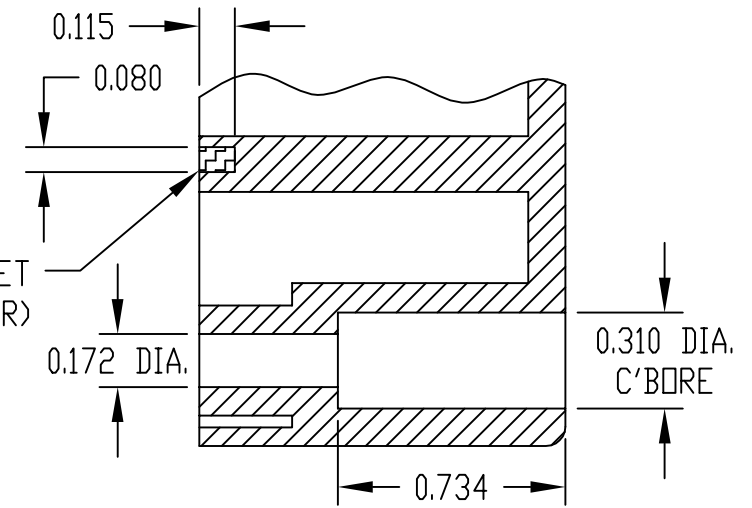

**DETAIL "D"**

SILICONE GASKET (CLEAR)

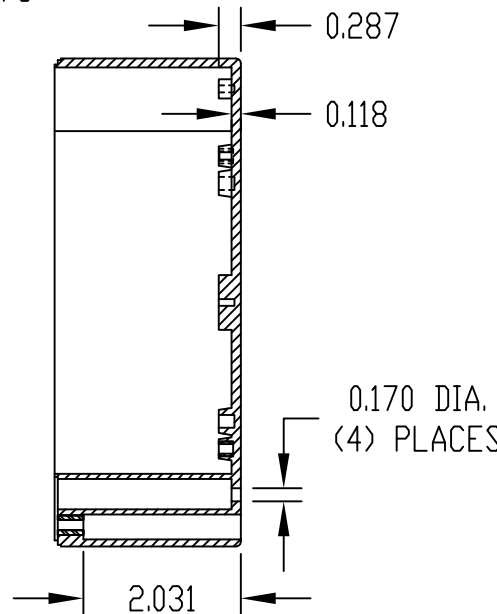

**SECTION "A-A"**

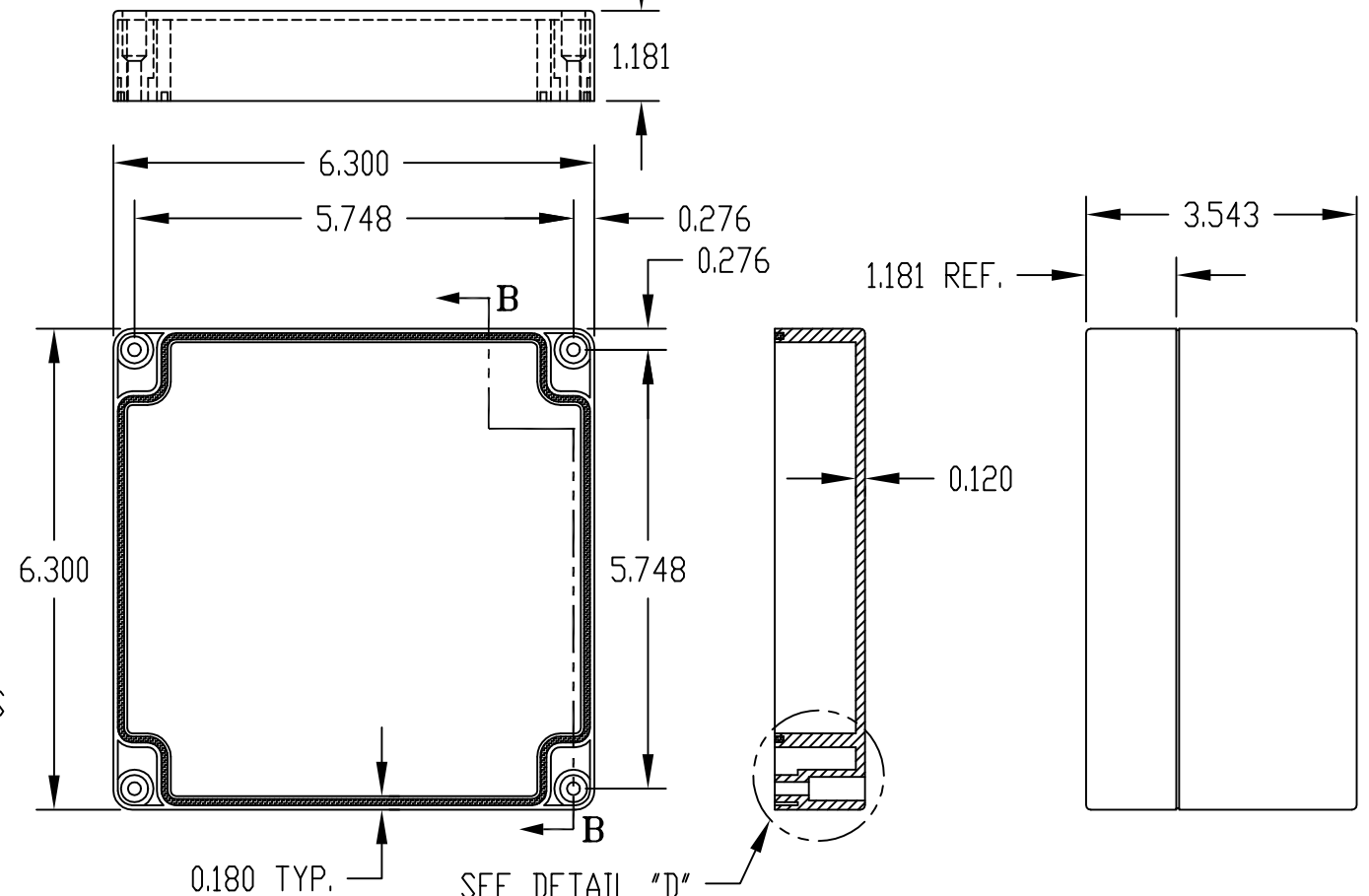

**COVER**

**SECTION "B-B"**

NOTE: ALL DIMENSIONS HAVE ±0.015 TOLERANCE UNLESS OTHERWISE SPECIFIED.

PART NUMBER	MATERIAL		FINISH		HARDWARE KIT
	BODY	COVER	BODY	COVER	
PN-1339	POLYCARBONATE		LIGHT GRAY		KIT CONTAINS (4) M4 x 20mm (0.787") LG. SCREWS FOR ASSEMBLY
PN-1339-C	POLYCARBONATE		LIGHT GRAY	CLEAR	
PN-1339-DG	HIGH-IMPACT ABS		DARK GRAY		