

PART NAME

PLASTICASE

PART No.

PC-11495

MATERIAL: BODY TOP & BOTTOM, REAR PANEL _____ ABS THERMOPLASTIC (UL94-HB RATED)
 UPPER SLOPE PANEL _____ 0.063 THK. ALUMINUM
 LOWER SLOPE PANEL _____ 0.100 THK. ALUMINUM

FINISH: BODY TOP & BOTTOM _____ LIGHT GRAY
 REAR PANEL _____ DARK GRAY
 SLOPE PANELS _____ NATURAL

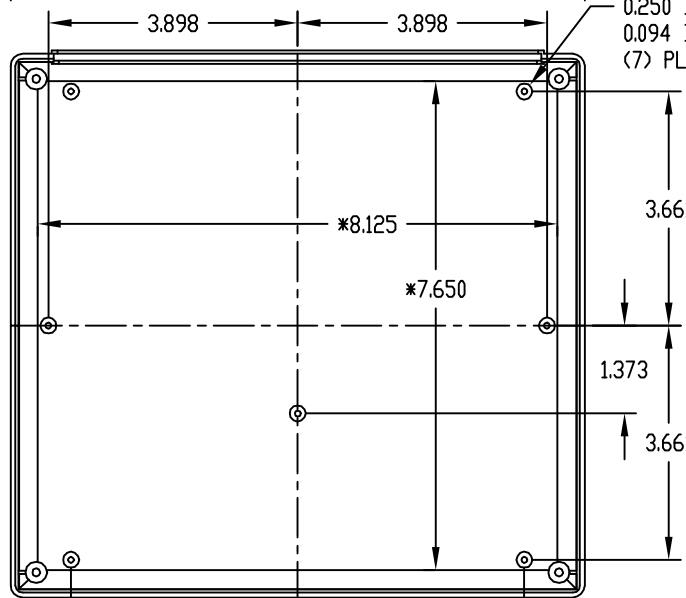
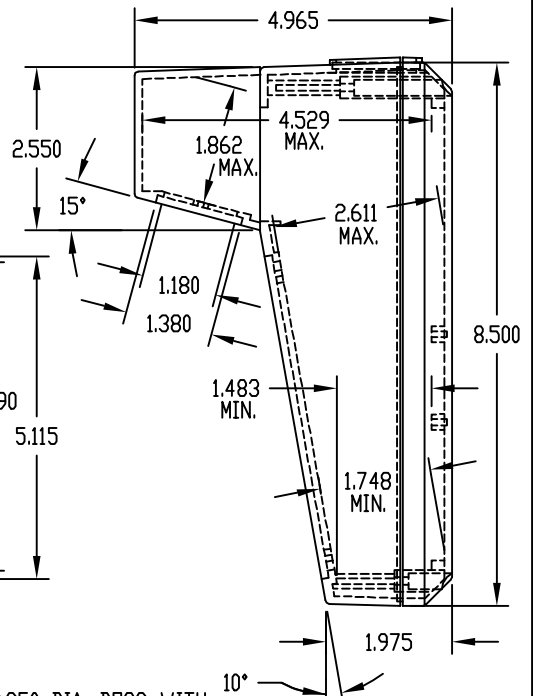
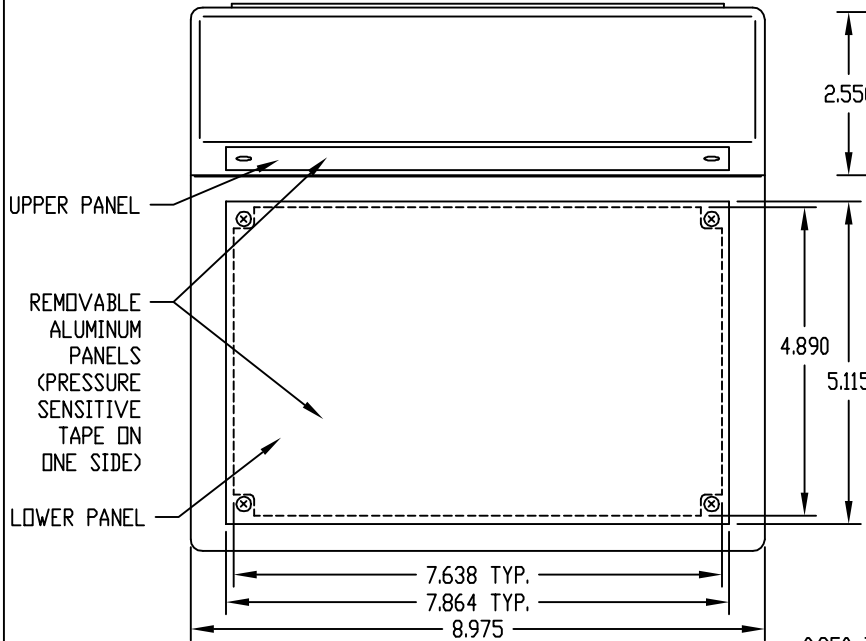

BODY BOTTOM (WITH BODY TOP REMOVED)

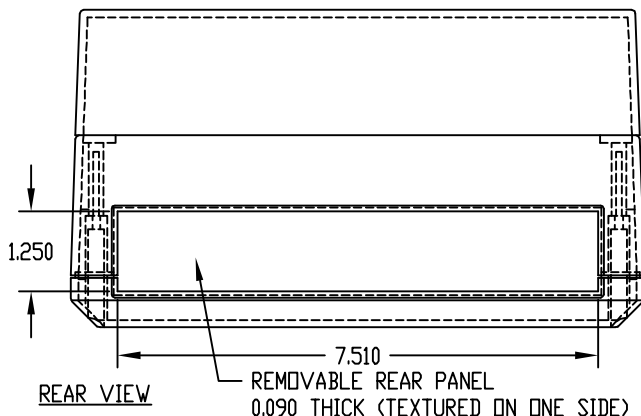

FOUR (4) M3 x 0.630" LG. SCREWS SUPPLIED FOR ASSEMBLING BODY TOP TO BOTTOM

SIX (6) M3 x 0.315" LG. CSK. SCREWS SUPPLIED FOR ASSEMBLING SLOPE PANELS TO BODY TOP

FOUR (4) RUBBER STICK-ON FEET SUPPLIED

MOUNTING BOSSES USE EITHER M2.5 METRIC OR #4 STD. SHEET METAL SCREWS x 0.188" LG. (NOT SUPPLIED)

NOTE: ALL DIMENSIONS HAVE ±0.015 TOLERANCE UNLESS OTHERWISE SPECIFIED

* THESE INSIDE DIMENSIONS ARE TAKEN FROM CLOSED END OF THE BOX