

PART NAME

PLASTICASE

PART No.

PC-11460, PC-11461 & PC-11462

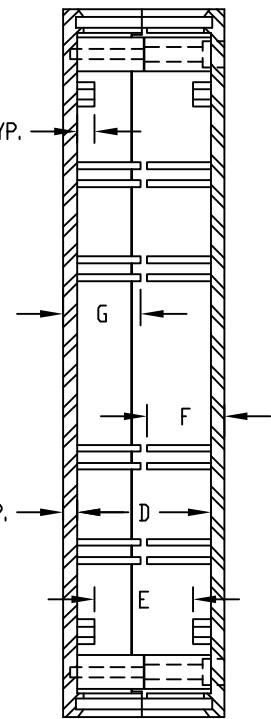
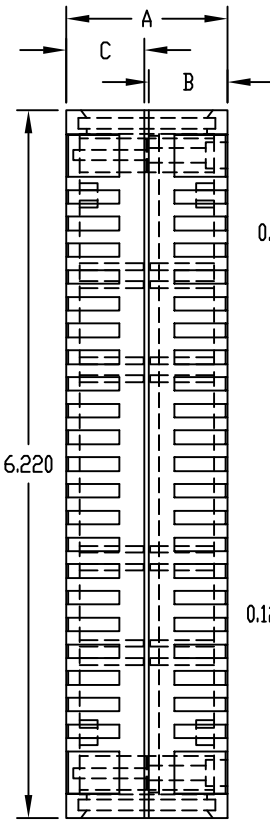
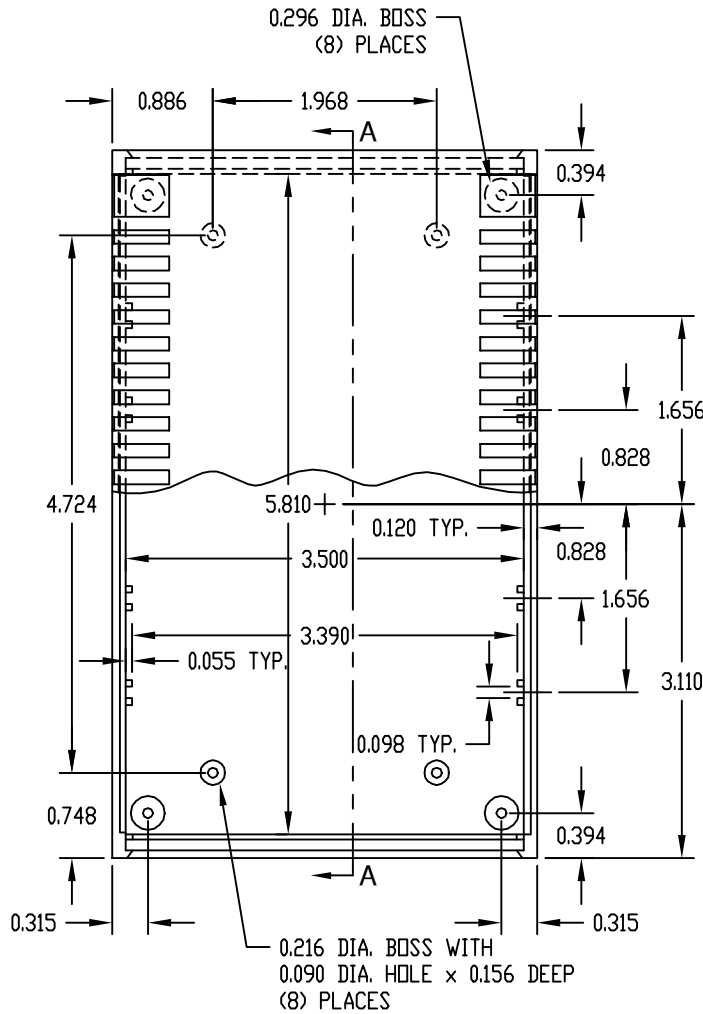

SECTION A-A

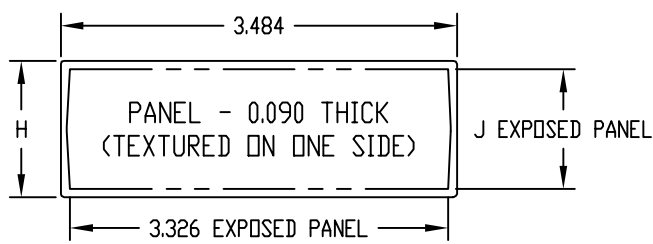
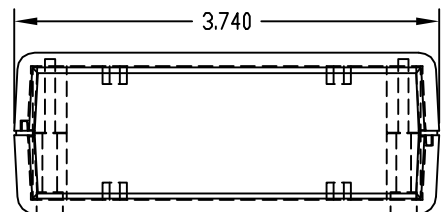

MATERIAL: ABS THERMOPLASTIC (UL 94-HB RATED)

FINISH: TOP & BOTTOM _____ LIGHT GRAY
 PANELS _____ DARK GRAY

FOR PC-11460 & PC-11461
 FOUR (4) M3 x 1.000 LG SCREWS SUPPLIED
 FOR ASSEMBLING BOTTOM TO TOP.

FOR PC-11462
 FOUR (4) M3 x 1.218 LG SCREWS SUPPLIED
 FOR ASSEMBLING BOTTOM TO TOP.

FOUR (4) RUBBER STICK-ON FEET SUPPLIED.

MOUNTING BOSSES USE EITHER M2.5 METRIC
 OR #4 STD. SHEET METAL SCREWS x 3/16 LG.
 (NOT SUPPLIED)

NOTE: ALL DIMENSIONS HAVE ±0.015 TOLERANCE
 UNLESS OTHERWISE SPECIFIED.

PART NO.	A	B	C	D	E	F	G	H	J
PC-11460	1.417	0.689	0.689	1.177	0.865	0.680	0.680	1.200	1.057
PC-11461	1.850	0.689	1.122	1.610	1.298	0.680	1.113	1.633	1.490
PC-11462	2.283	1.122	1.122	2.043	1.731	1.113	1.113	2.066	1.923