

BODY ASSEMBLY

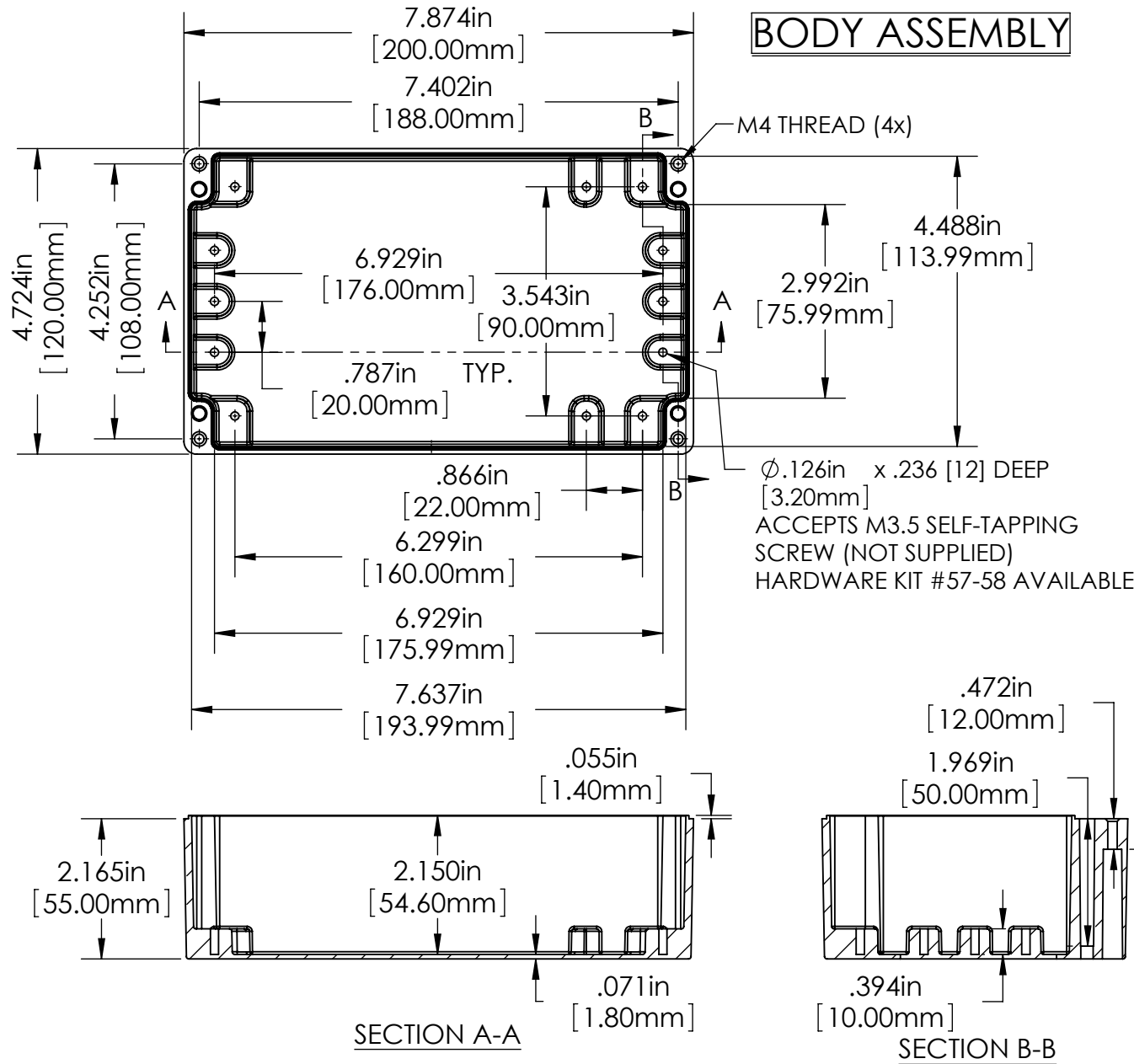

COVER

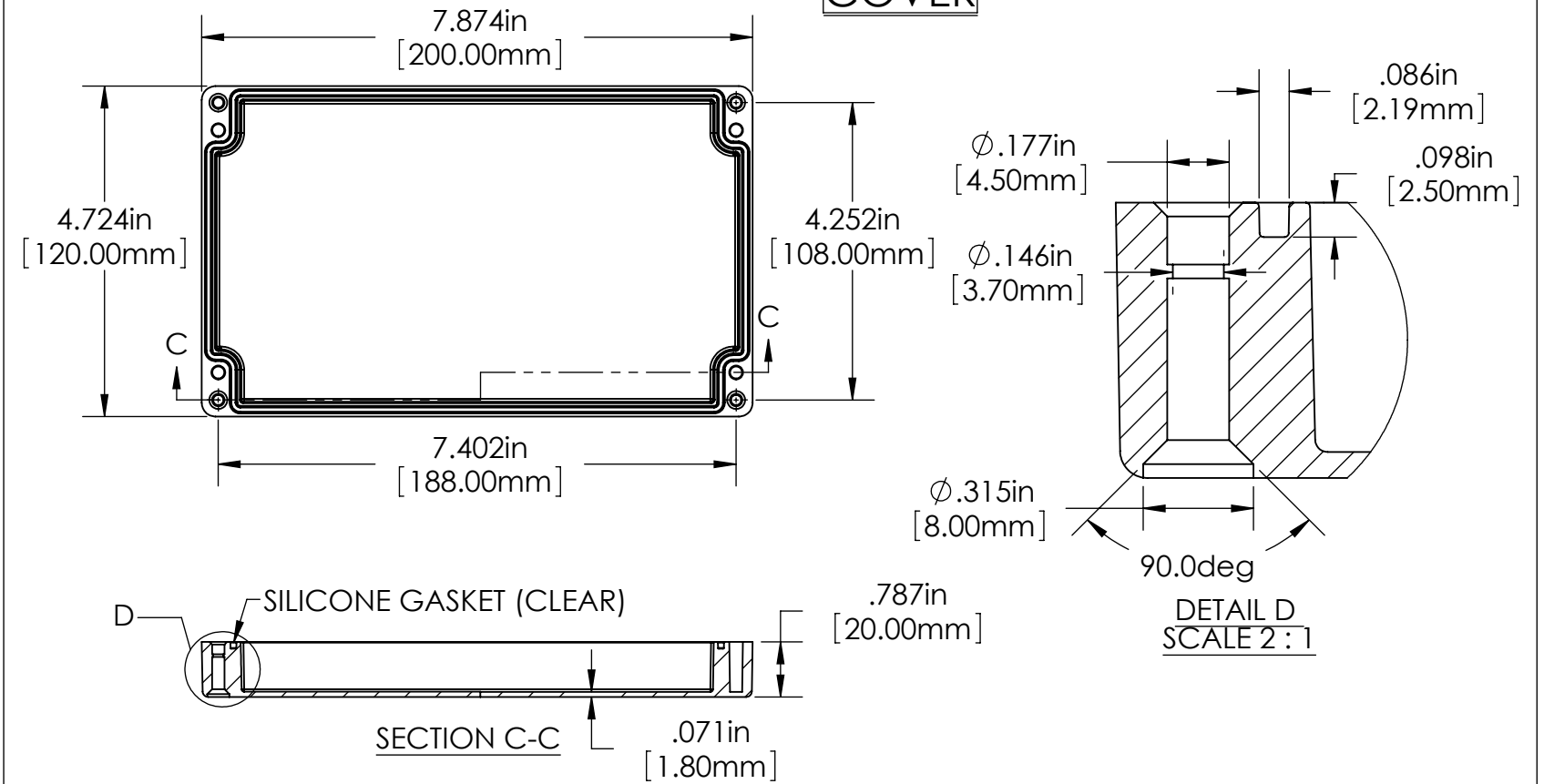

FOUR (4) M4 x 32mm (1.26") LG. FLAT HD. STAINLESS STEEL SCREWS SUPPLIED FOR ASSEMBLY OF COVER

ASSEMBLY

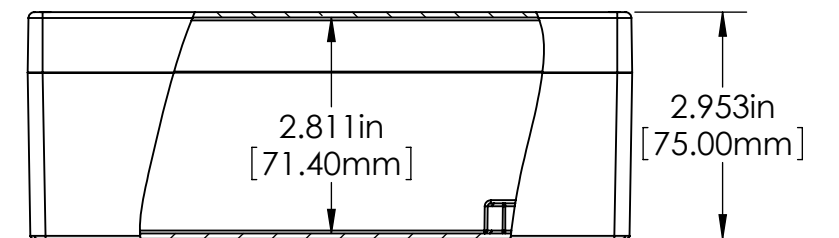
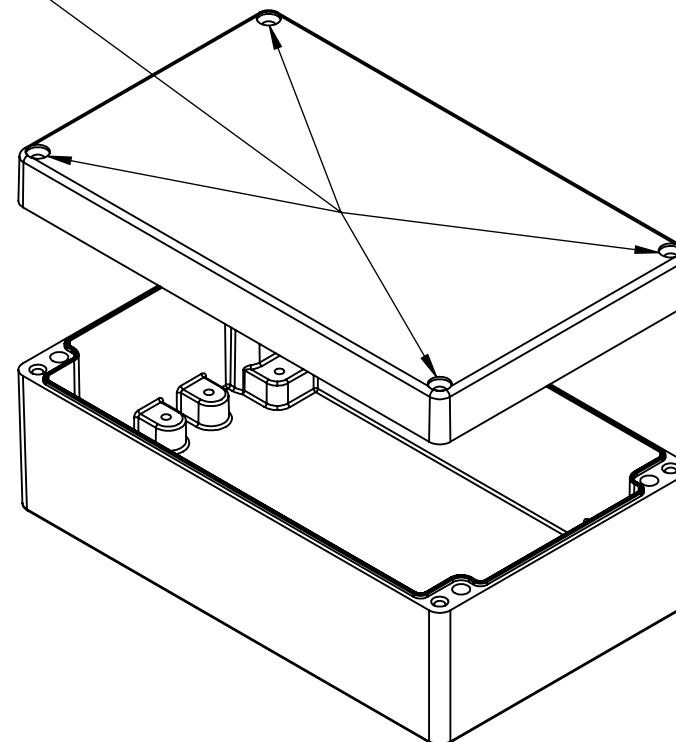
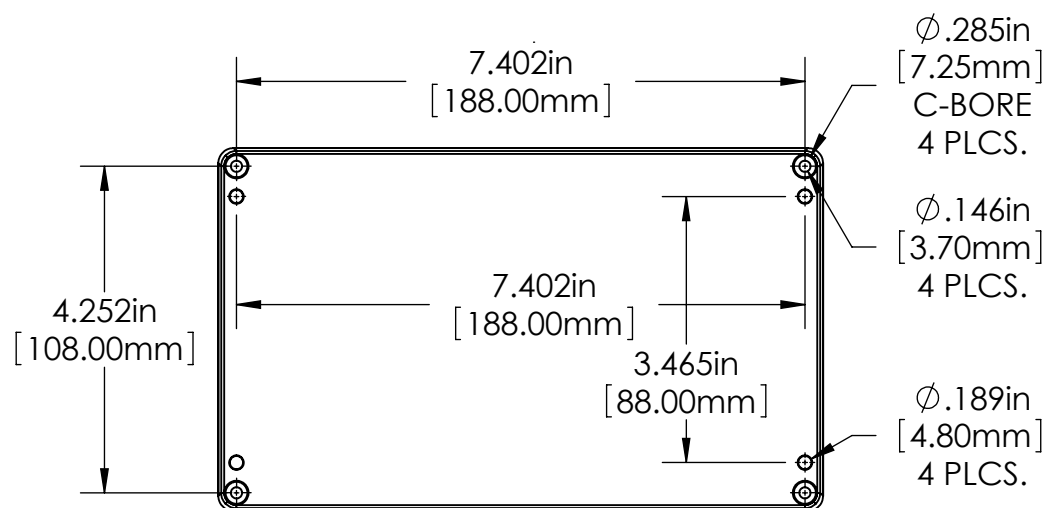

MATERIAL: ALUMINUM (ADC-12 ALLOY)
 FINISH: NATURAL
 TOLERANCES: ±.015 [±.38]