

PART NAME

PLASTICASE (STYLE D)

PART No.

PC-11480 & PC-11480-A & PC-11480-LG & PC-11480-LGA

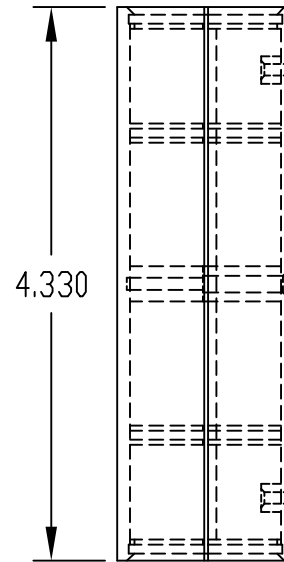
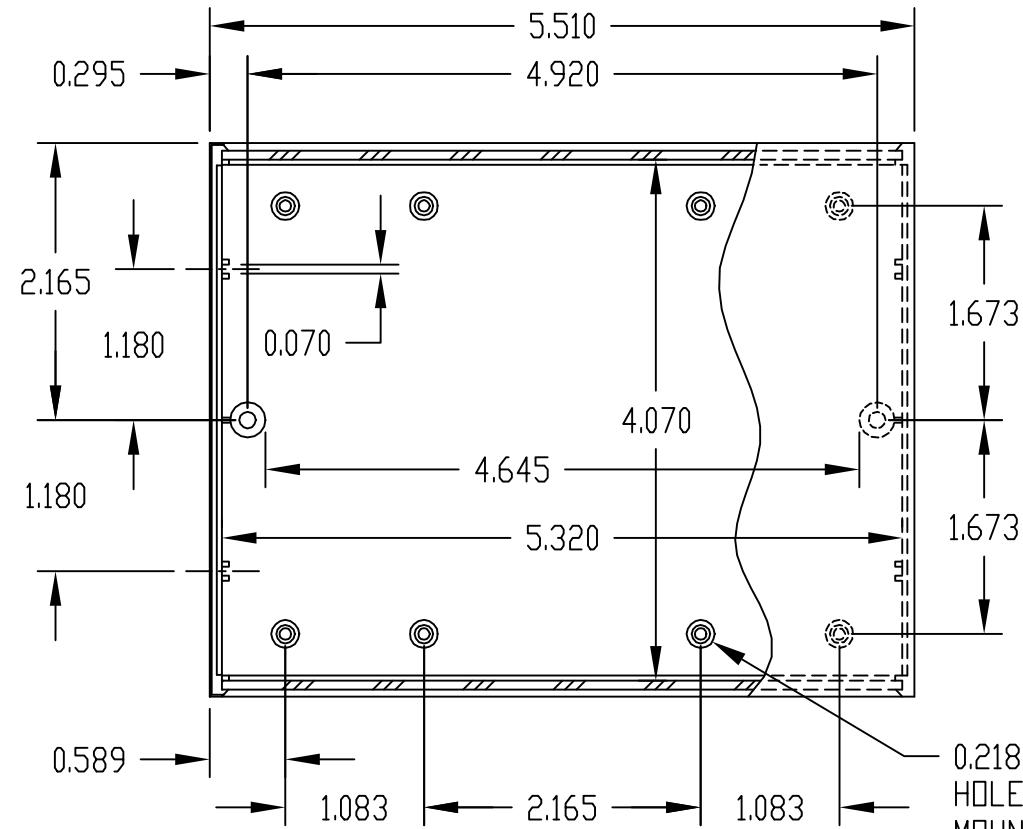

MATERIAL & FINISH:

(NO SUFFIX) UL94V-0 FLAME RETARDANT ABS
DARK GRAY PLASTIC COVERS WITH
LIGHT GRAY PLASTIC PANELS.

(SUFFIX -A) UL94V-0 FLAME RETARDANT ABS
DARK GRAY PLASTIC COVERS WITH
NATURAL FINISH ALUMINUM PANELS.

(SUFFIX -LG) HIGH-IMPACT ABS
LIGHT GRAY PLASTIC COVERS WITH
BLACK PLASTIC PANELS.

(SUFFIX -LGA) HIGH-IMPACT ABS
LIGHT GRAY PLASTIC COVERS WITH
NATURAL FINISH ALUMINUM PANELS.

TWO (2) M3 x 0.812" LG. SCREWS
SUPPLIED FOR ASSEMBLY.

NOTE: ALL DIMENSIONS HAVE ±0.015 TOLERANCE
UNLESS OTHERWISE SPECIFIED

0.218 DIA. BOSS WITH 0.090 DIA.
HOLE x 0.218 DEEP - (8) PLACES
MOUNTING BOSSES USE EITHER M2.5 METRIC
OR #4 STD. SHEET METAL SCREWS x 0.188" LG.
(NOT SUPPLIED)

