

PART NAME

EXTRUDED ALUMINUM BOX

PART No.

EX-4521 & EX-4522 & EX-4523

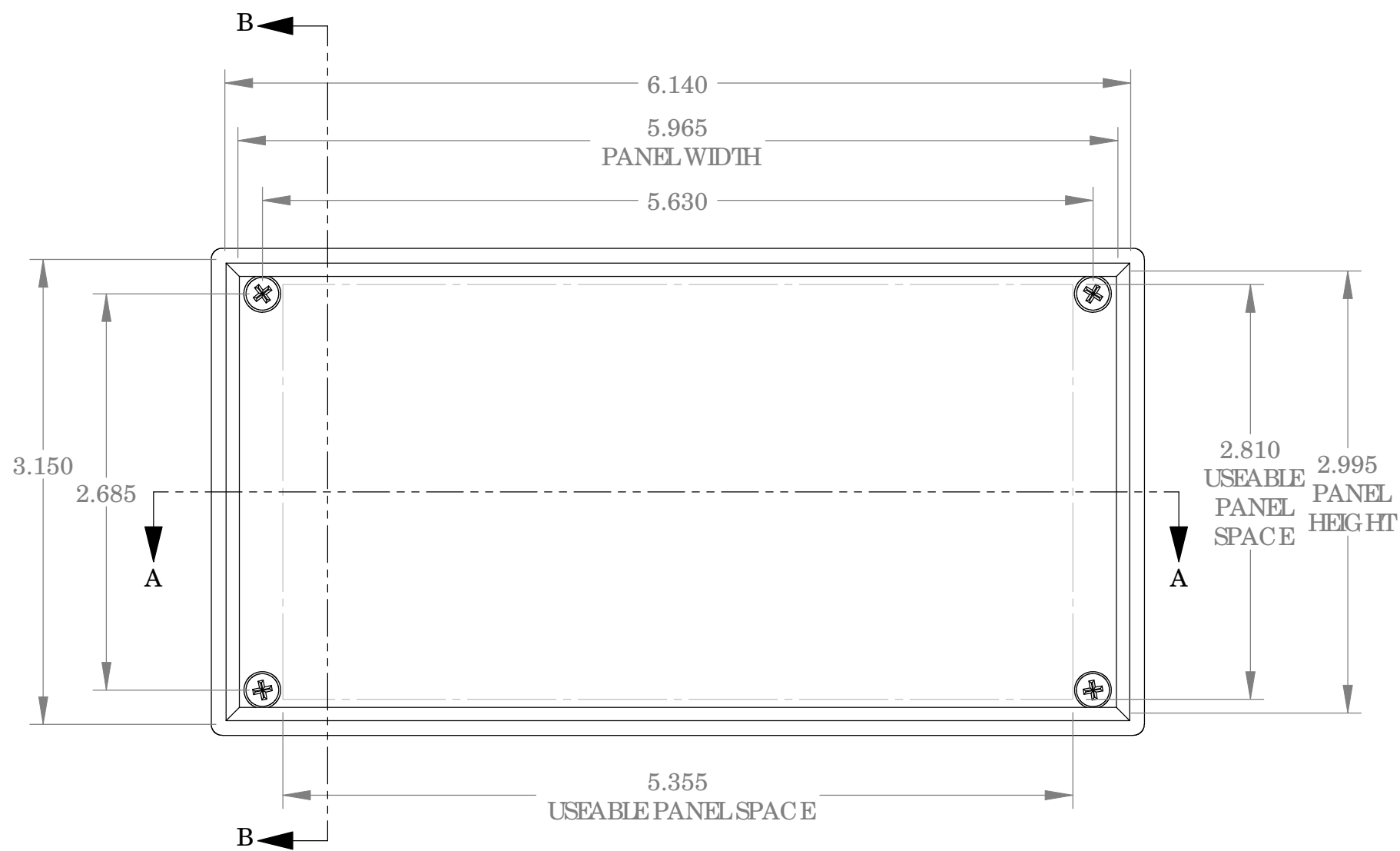
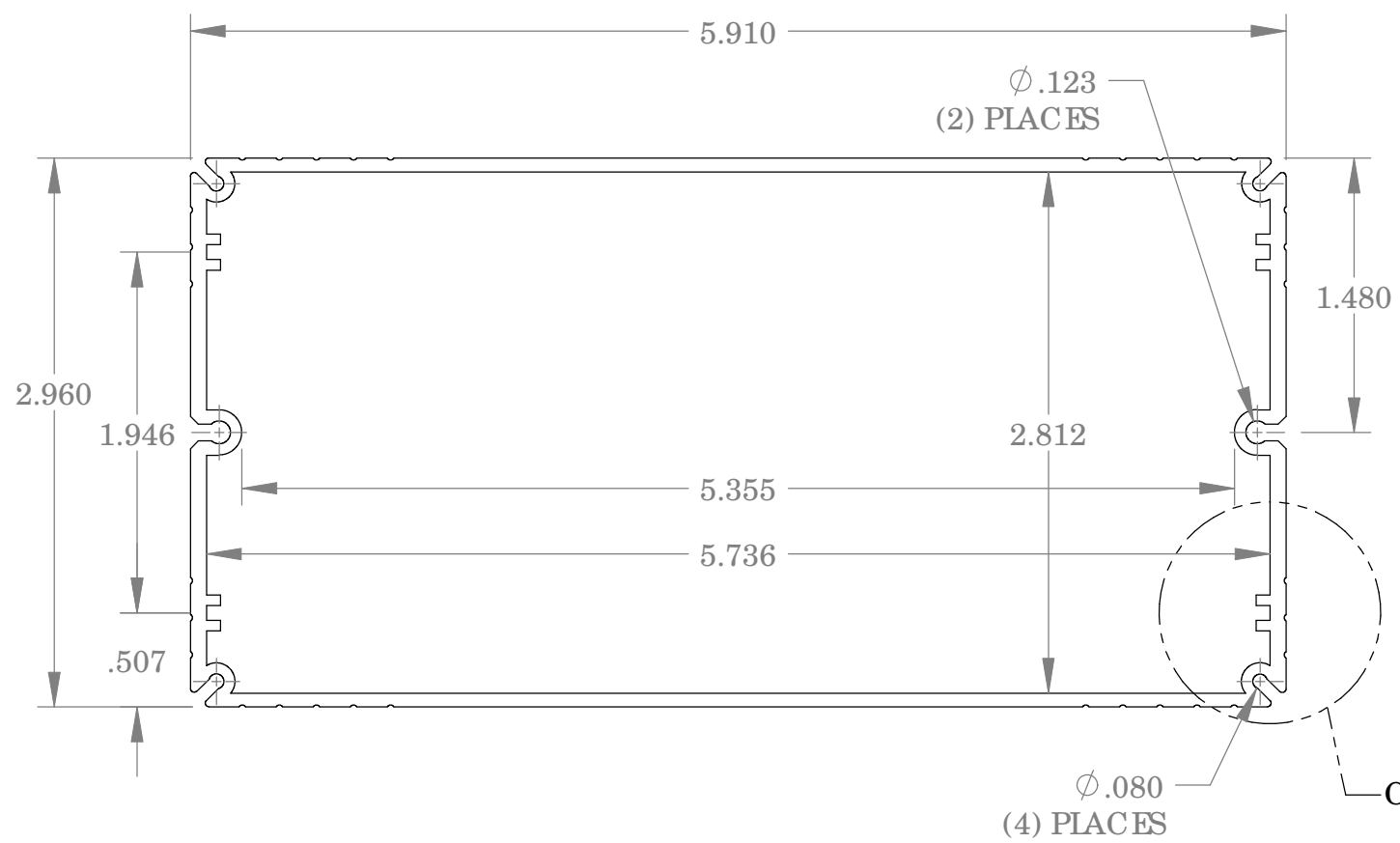
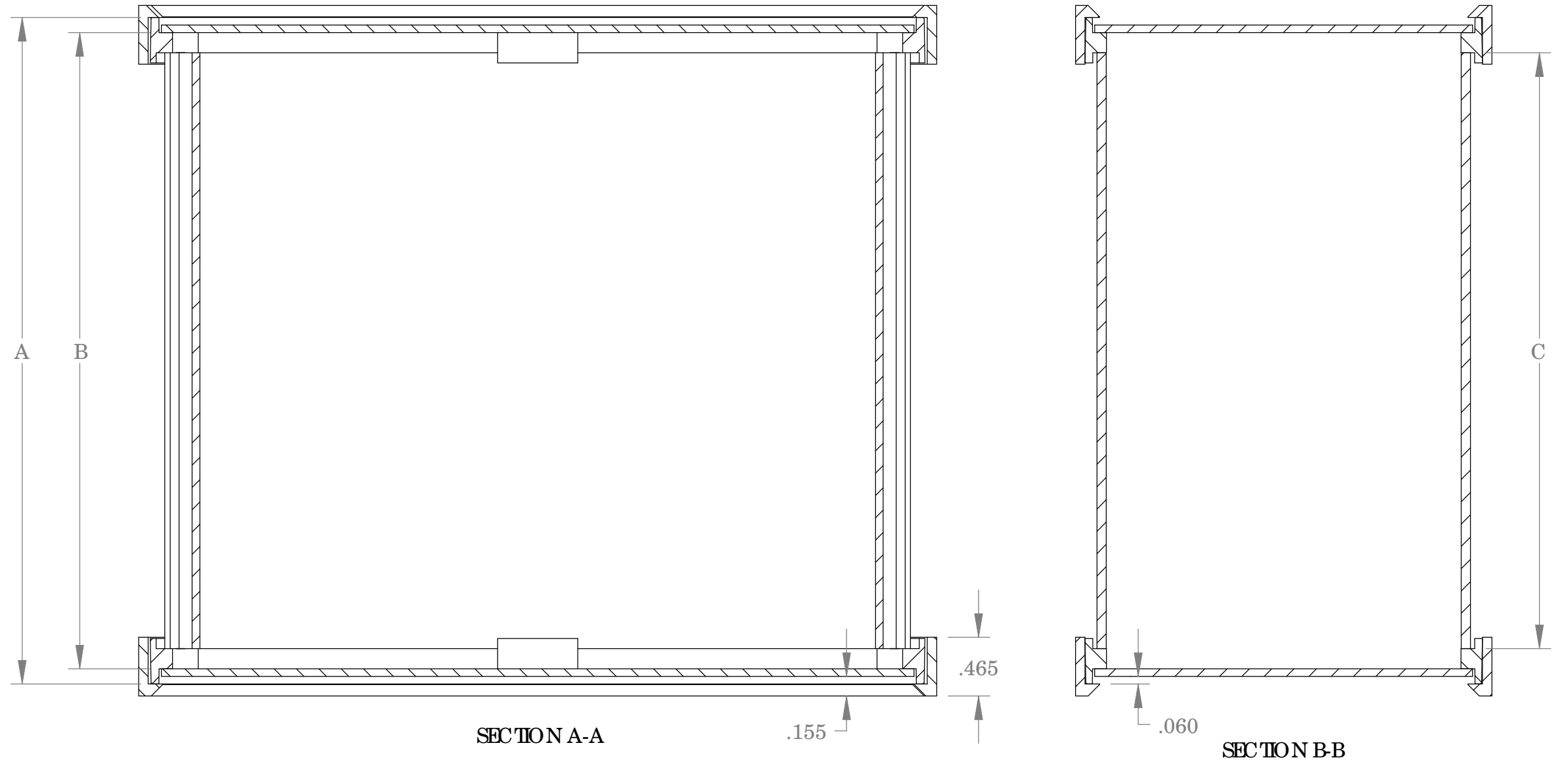
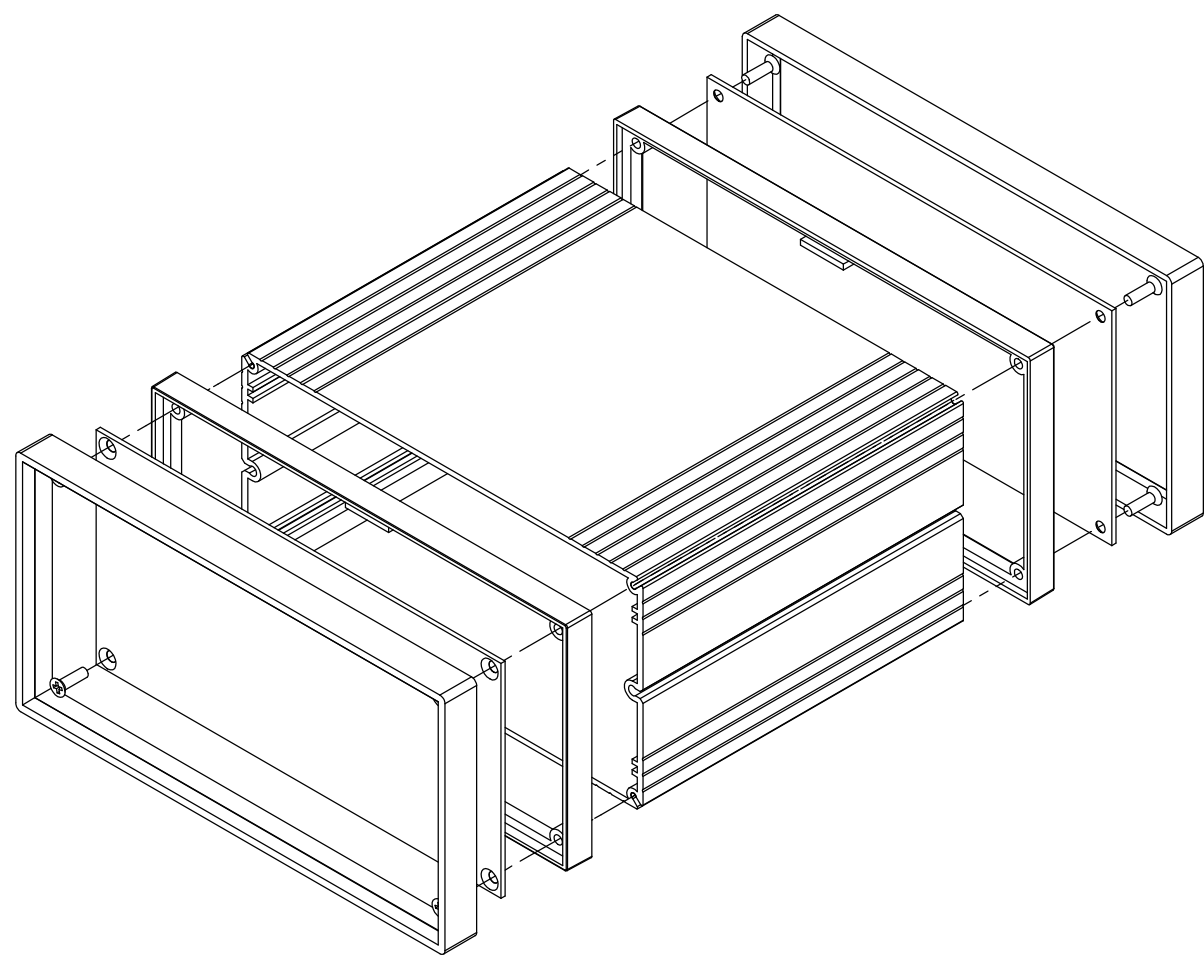

**MATERIAL:**  
 BODY - ALUMINUM  
 BEZEL - UL94V-0 ABS  
 PANEL - .060 THK ALUMINUM

**FINISH:**  
 BODY - SILVER COATING  
 BEZEL - BLACK  
 PANEL - NATURAL

**EIGHT(8) M3 x 10mm FLATHEAD SCREWS SUPPLIED TO ATTACH END PANELS AND BEZELS TO BODY (ALTERNATE SCREW # 4 x 5/8 FLATHEAD THREAD CUTTING SCREWS CAN BE SUBSTITUTED) RECOMMEND INSERTION TORQUE 6-8 in-lb.s.**

**ALL DIMENSIONS HAVE  $\pm .015$  TOLERANCE UNLESS OTHERWISE SPECIFIED**

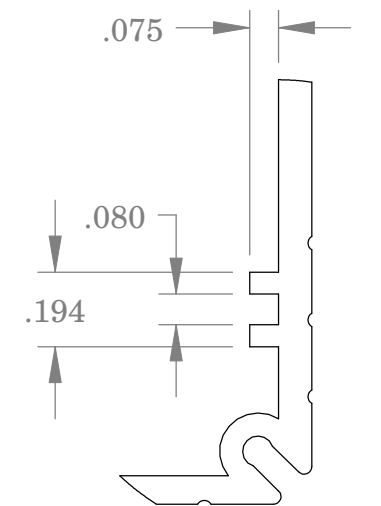

DETAIL C

PART No.	EXTERNAL		INTERNAL CLEARANCE	
	A	B	C	
EX-4521	5.38	5.14	4.82	
EX-4522	6.96	6.72	6.40	
EX-4523	9.32	9.08	8.76	