

LID

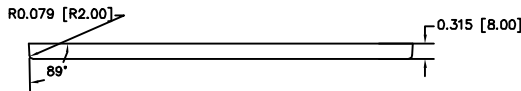

PANEL

TOLERANCES:	(DIMENSIONS)	PART NO.	DESCRIPTION
FORM AND FINISH AS SHOWN UNLESS OTHERWISE SPECIFIED	DEC. 98	PLASTIKASE, INC.	PLASTIKASE STYLE I 7.87 X 4.76 X 1.57
FORM AND FINISH AS SHOWN UNLESS OTHERWISE SPECIFIED	DEC. 98	VILLALBA, INC.	PC-11478

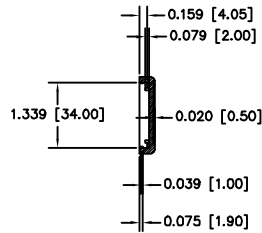
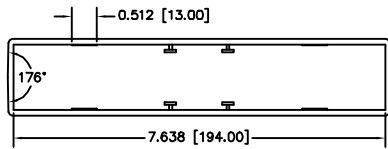
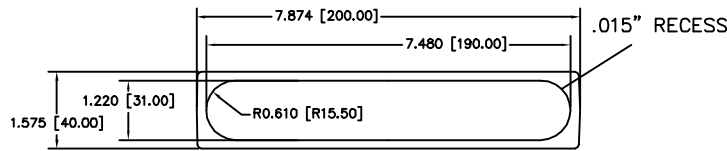
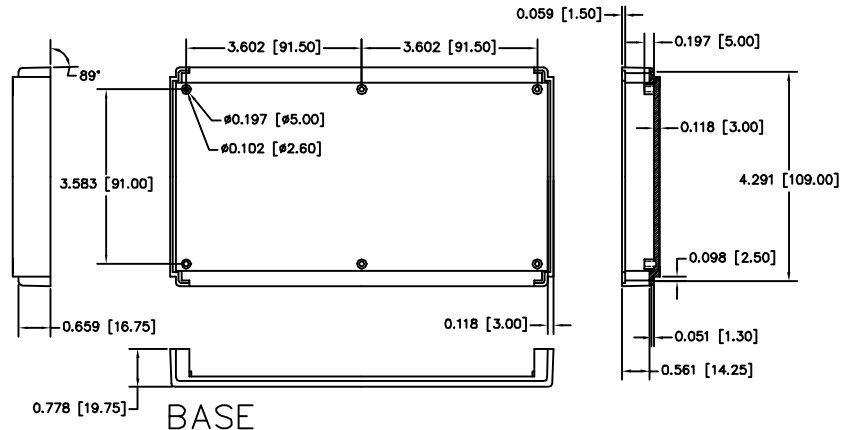
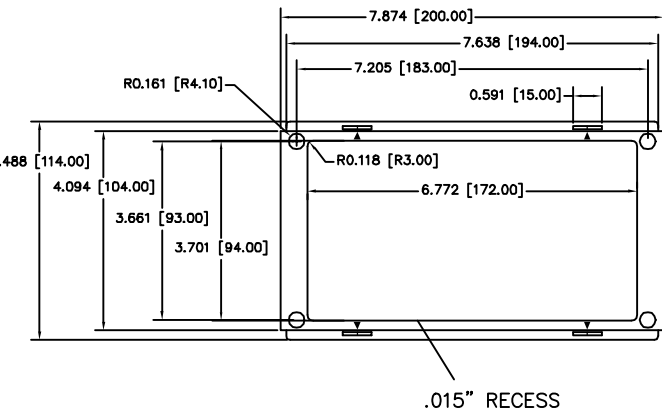

BASE

.015" RECESS

MATERIAL : HIGH IMPACT UL-94-HB ABS .  
 COLOR:  
 LID & BASE ARE MOLDED IN LIGHT GREY COLOR  
 FRONT & END PANELS  
 ARE MOLDED IN DARK GREY COLOR  
 FINISH:  
 FRONT & END PANELS ARE SMOOTH WITH TEXTURE ONLY IN THE RECESS AREA.  
 LID & BASE ARE SMOOTH WITH TEXTURE ONLY IN OUTSIDE RAISED AREA.  
 SIX (6) INTERNAL BOSSES ON BASE & LID ARE  
 AVAILABLE FOR PCB ASSEMBLY. USE M2.5 OR  
 #4 STD SHEET METAL SCREWS.  
 ALL DIMENSIONAL TOLERANCES ARE +.015  
 RUBBER FEET PART NUMBER \_\_\_\_\_ AVAILABLE AS ACCESSORY

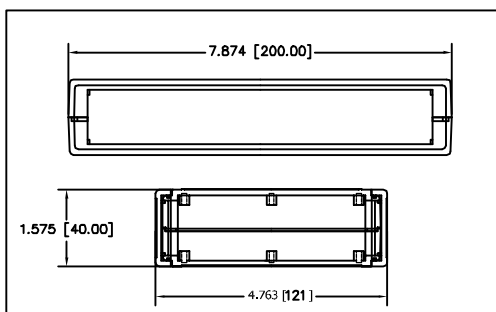

TOLERANCES:	(DIMENSIONS)	PART NO.	DESCRIPTION
FORM AND FINISH AS SHOWN UNLESS OTHERWISE SPECIFIED	DEC. 98	PLASTIKASE, INC.	PLASTIKASE STYLE I 7.87 X 4.76 X 1.57
FORM AND FINISH AS SHOWN UNLESS OTHERWISE SPECIFIED	DEC. 98	VILLALBA, INC.	PC-11478