

PART NAME	HAND HAND BOX (STYLE N)	PART No.	HH-3610-BC	REV. DATE	8-27-08
-----------	-------------------------	----------	------------	-----------	---------

MATERIAL: HIGH IMPACT ABS WITH UL94V-0 FLAMMABILITY RATING  
FINISH: TEXTURED BLACK

ALL DIMENSIONS HAVE  $\pm 0.015$  TOLERANCE  
FOUR (4) M3 x 1/2" LG. FLAT HD. STAINLESS STEEL SCREWS SUPPLIED FOR ASSEMBLY

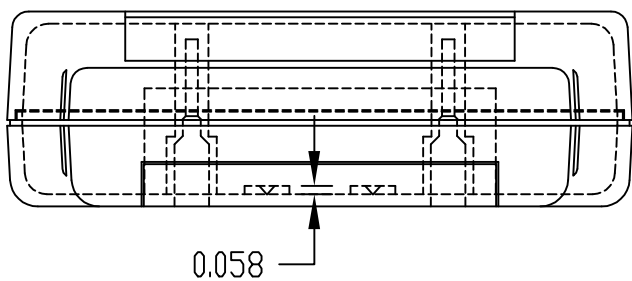
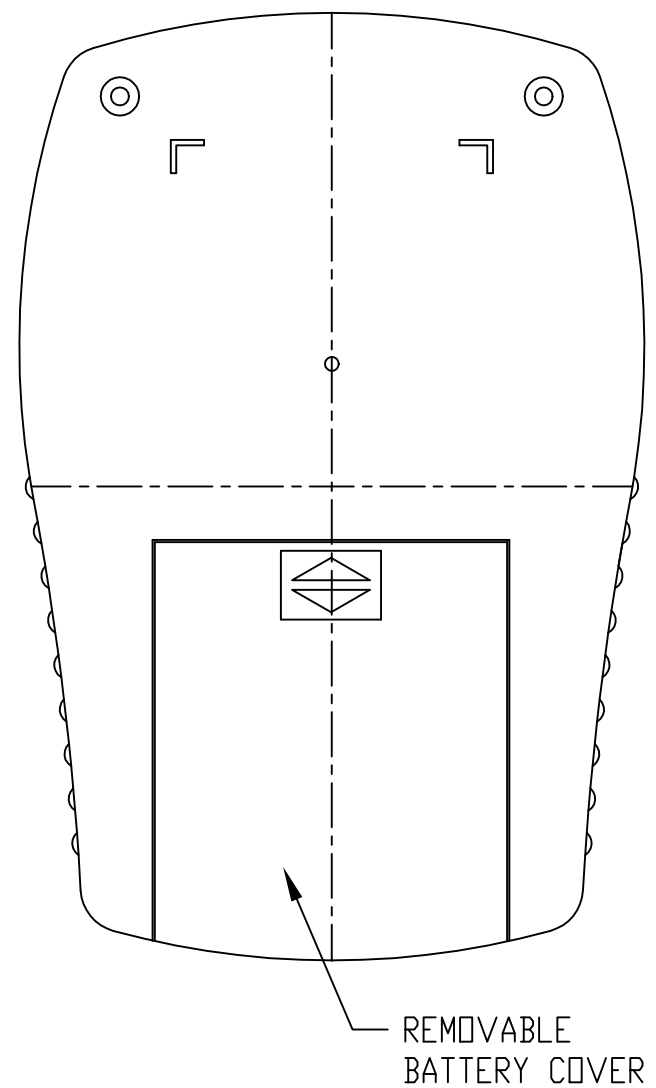
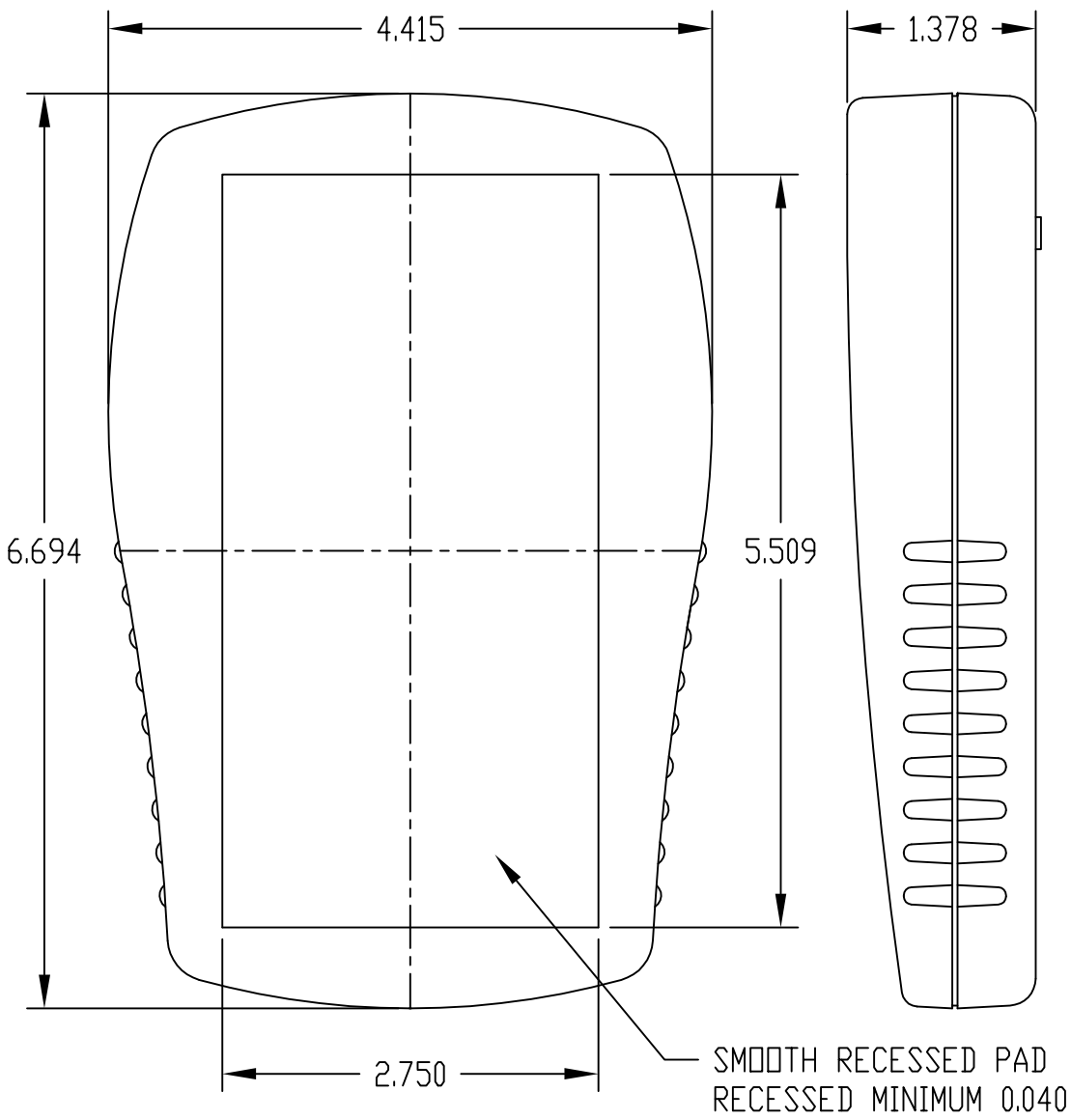

0.236 DIA. BOSS WITH 0.087 DIA. HOLE (4) PLACES

NOTE: MOUNTING BOSSES USE EITHER M2.5 METRIC OR #4 STD. SHEET METAL SCREWS x 3/16" LG. (NOT SUPPLIED)

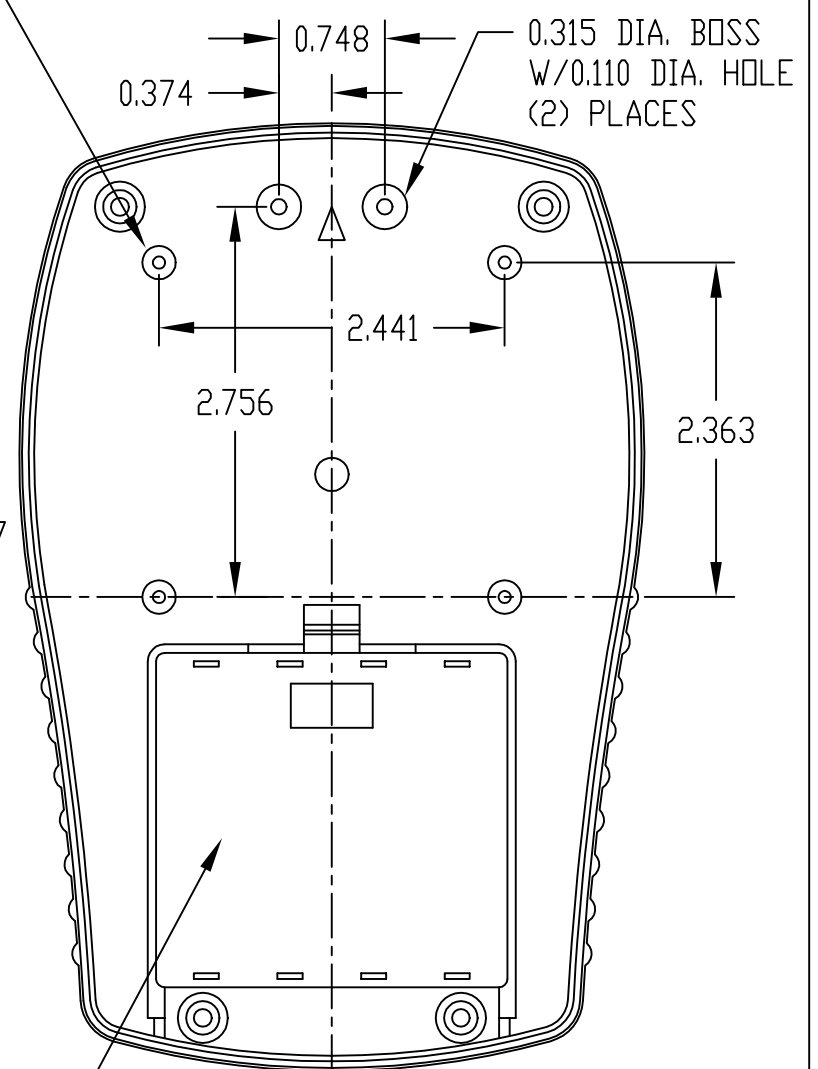
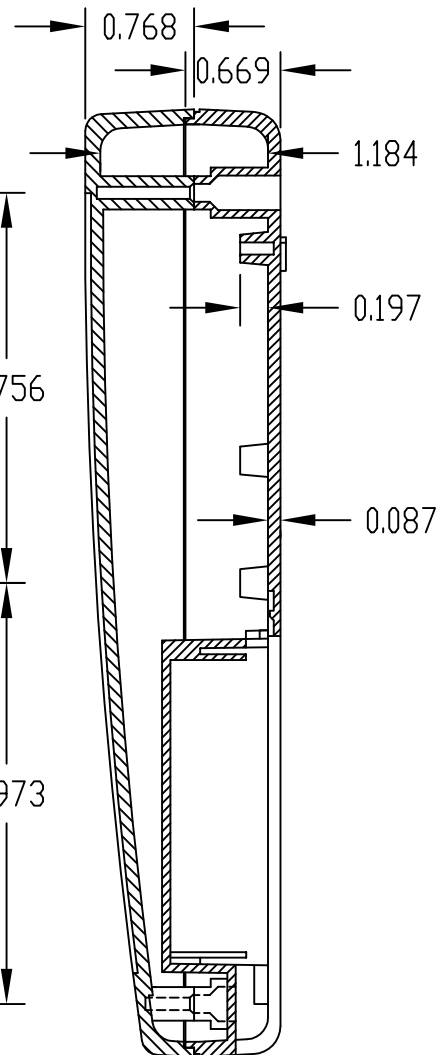
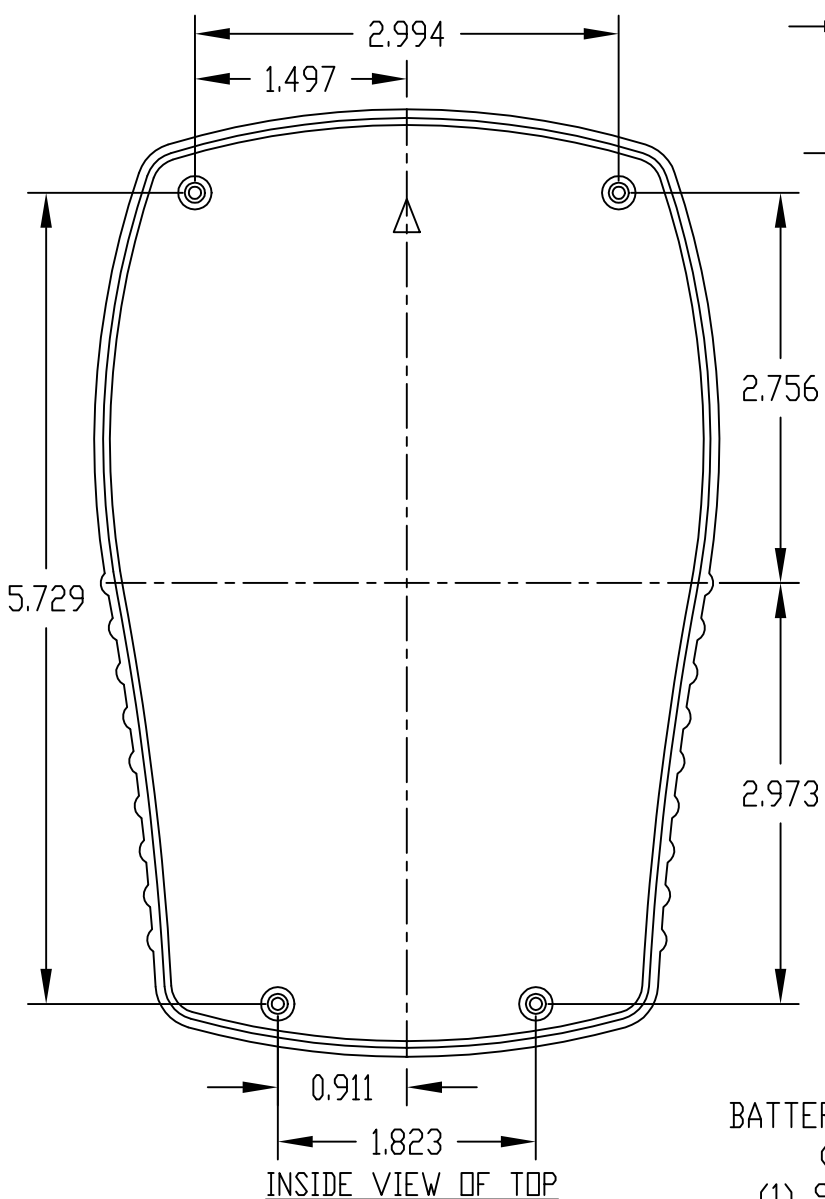

BATTERY COMPARTMENT ACCEPTS (2) OR (4) AA, (1) 9V, OR (1) 9V AND (2) AA BATTERIES