

PART  
NAME

HAND HAND BOX (STYLE L)

PART  
No.

HH-3580

REV.  
DATE

MATERIAL: HIGH IMPACT ABS WITH UL94V-0  
FLAMMABILITY RATING  
FINISH: TEXTURED BLACK

ALL DIMENSIONS HAVE  $\pm 0.015$  TOLERANCE  
FOUR (4) M3 x 1/2" LG. FLAT HD. STAINLESS  
STEEL SCREWS SUPPLIED FOR ASSEMBLY

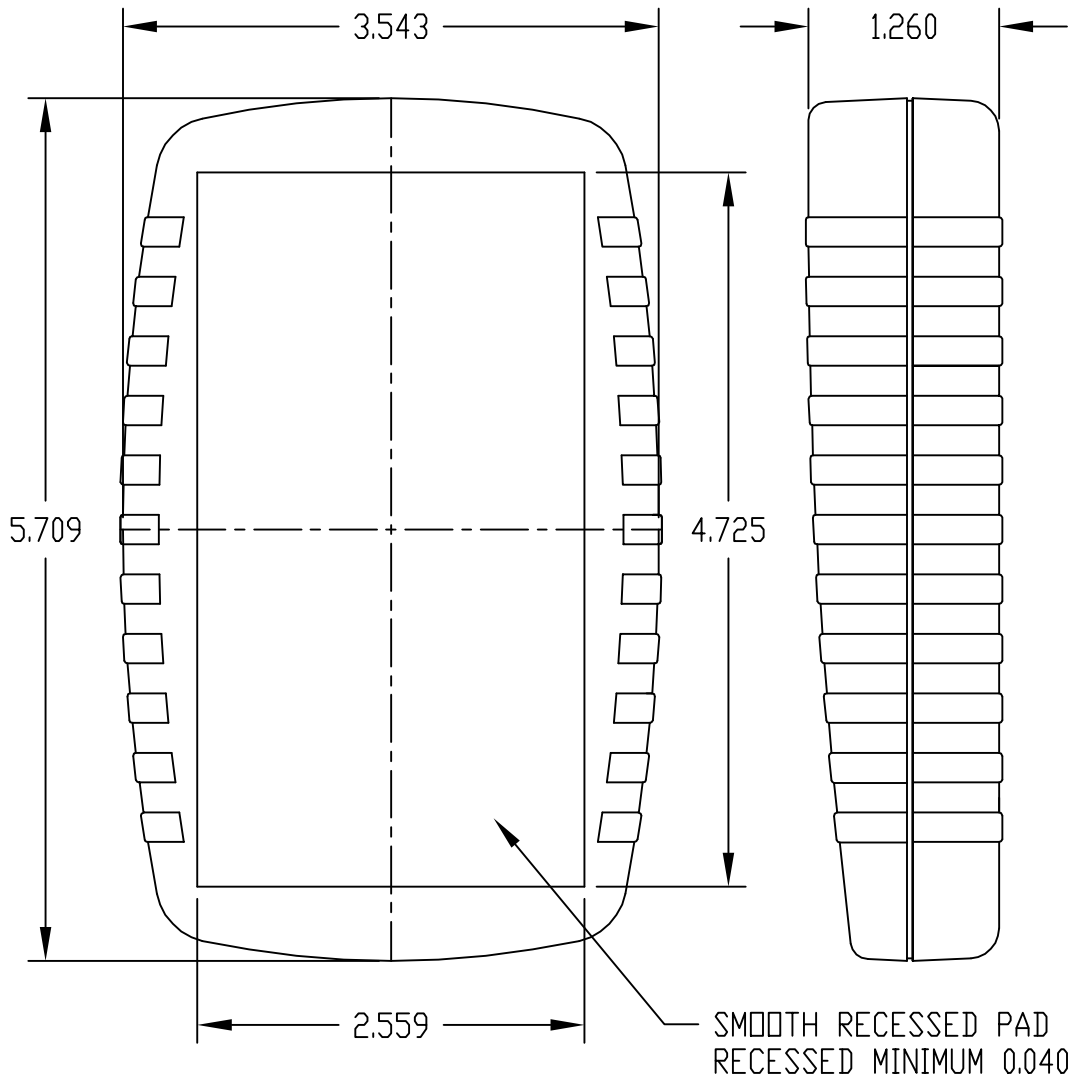

NOTE: MOUNTING BOSSES USE EITHER M2.5 METRIC  
OR #4 STD. SHEET METAL SCREWS x 3/16" LG.  
(NOT SUPPLIED)

0.236 DIA. BOSS  
WITH 0.087 DIA. HOLE  
(6) PLACES

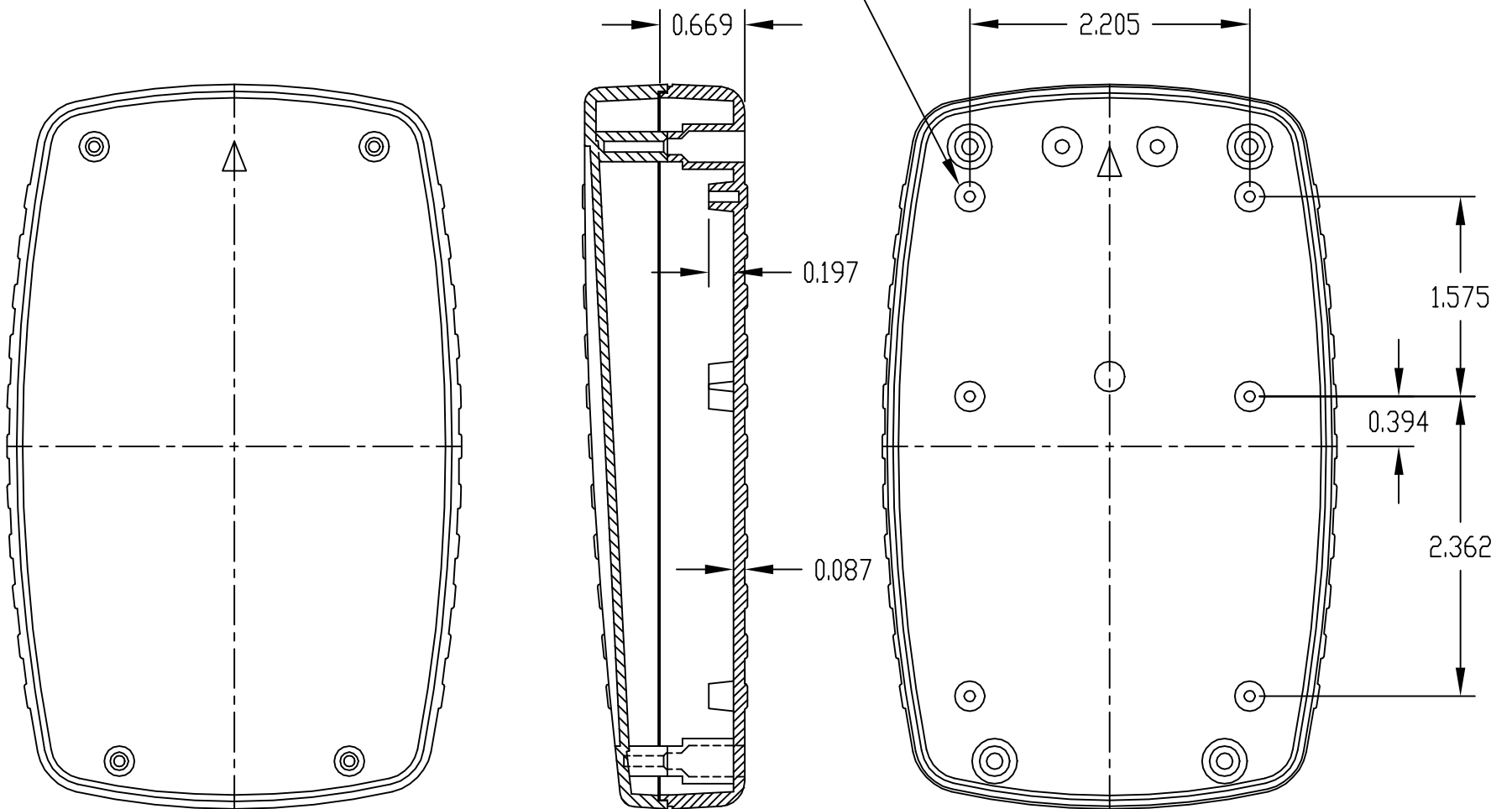

INSIDE VIEW OF TOP

INSIDE VIEW OF BOTTOM