

PART
NAME

UTILIBOX (STYLE D)

PART
No.

CU-741

MATERIAL:

BODY & COVER — HIGH-IMPACT POLYSTYRENE

TWO (2) #4 x 0.562" LG SCREWS
SUPPLIED FOR ASSEMBLY.

FINISH:

BODY & COVER — BLACK TEXTURED

NOTE: ALL DIMENSIONS HAVE ±0.010 TOLERANCE
UNLESS OTHERWISE SPECIFIED.

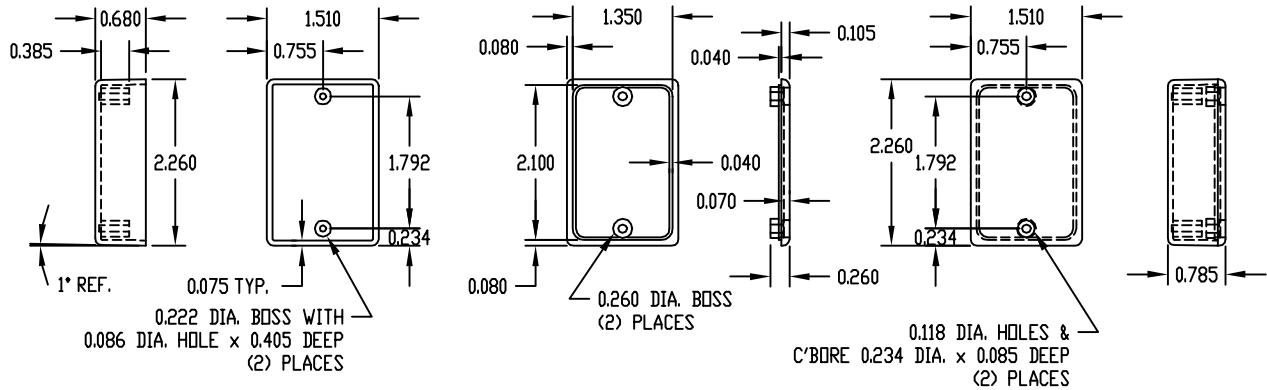

PART
NAME

UTILIBOX (STYLE D)

PART
No.

CU-741-MB

MATERIAL:

BODY & COVER — HIGH-IMPACT POLYSTYRENE

TWO (2) #4 x 0.562" LG SCREWS
SUPPLIED FOR ASSEMBLY.

FINISH:

BODY & COVER — BLACK TEXTURED

NOTE: ALL DIMENSIONS HAVE ±0.010 TOLERANCE
UNLESS OTHERWISE SPECIFIED.

