

PART NAME	CHASSIS BOTTOM PLATES	PART No.	BPA-1502 THRU BPA-1598
-----------	-----------------------	----------	------------------------

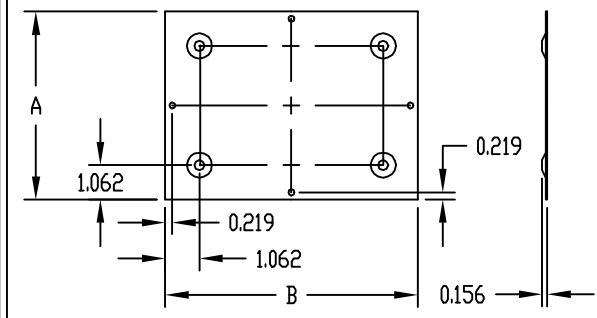

TYPE A

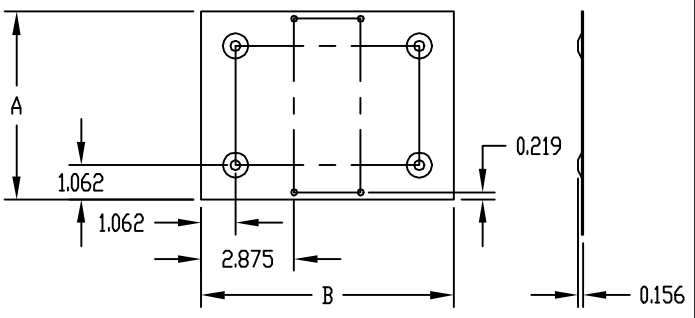

TYPE B

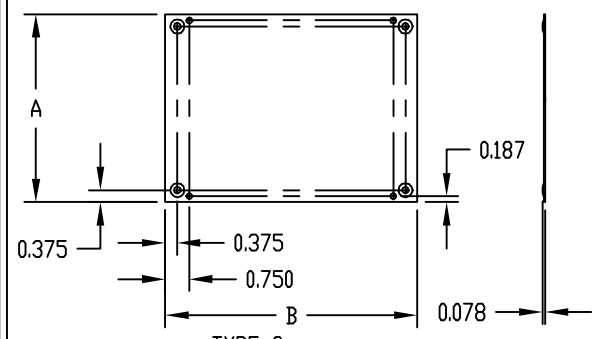

TYPE C

TYPE A AND TYPE B
(4) EMBOSSED FEET 0.781 DIA.

TYPE C
(4) EMBOSSED FEET 0.437 DIA.

MOUNTING HOLES 0.187 DIA.

MATERIAL:
"BPA" PREFIX 0.040 ALUMINUM

FINISH:
NATURAL

PART No. ALUMINUM NATURAL FINISH	A	B	TYPE	WGT. IN OZS.
BPA-1502	3.375	4.375	C	1
BPA-1504	3.875	4.875	C	2
BPA-1505	3.875	5.875	C	2
BPA-1507	4.375	7.875	C	3
BPA-1513	5.812	7.812	A	3
BPA-1514	5.812	13.812	B	5
BPA-1515	5.812	16.812	B	6
BPA-1516	6.812	14.812	B	8
BPA-1517	6.812	16.812	B	8
BPA-1518	7.812	9.812	B	4
BPA-1519	7.812	11.812	B	6
BPA-1520	7.812	16.812	B	8
BPA-1522	8.812	14.812	B	8
BPA-1523	9.812	11.812	B	8
BPA-1524	9.812	13.812	B	8
BPA-1527	11.812	11.812	A	10
BPA-1528	11.812	16.812	B	12
BPA-1529	13.812	16.812	B	15
BPA-1530	14.812	16.812	A	16
BPA-1531	16.812	16.812	A	17
BPA-1589	4.812	6.812	A	2
BPA-1590	4.875	9.375	C	2
BPA-1591	4.812	9.812	A	4
BPA-1592	6.812	6.812	A	3
BPA-1593	6.812	8.812	A	4
BPA-1594	6.812	10.812	B	4
BPA-1595	6.812	11.812	B	5
BPA-1596	6.812	12.812	B	8
BPA-1597	9.812	16.812	B	10
BPA-1598	12.812	16.812	B	14