

PNP SILICON HIGH FREQUENCY TRANSISTOR

FEATURES

- **HIGH GAIN BANDWIDTH PRODUCT:**
 $f_T = 5.5 \text{ GHz TYP}$
- **HIGH SPEED SWITCHING CHARACTERISTICS**
- **NPN COMPLIMENT AVAILABLE:** NE02133
- **HIGH INSERTION POWER GAIN:**
 $|S_{21E}|^2 = 10 \text{ dB at } 1 \text{ GHz}$

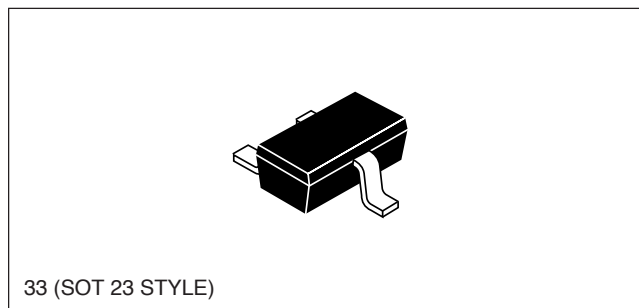

DESCRIPTION

The NE97833 PNP silicon transistor is designed for ultrahigh speed current mode switching applications and microwave amplifiers up to 3.5 GHz. The NE97833 offers excellent performance and reliability at low cost.

ELECTRICAL CHARACTERISTICS ($T_A = 25^\circ\text{C}$)

PART NUMBER EIAJ ¹ REGISTERED NUMBER PACKAGE OUTLINE			NE97833 2SA1978 33		
SYMBOLS	PARAMETERS AND CONDITIONS	UNITS	MIN	TYP	MAX
f_T	Gain Bandwidth Product at $V_{CE} = -10 \text{ V}$, $I_C = -15 \text{ mA}$	GHz	4.0	5.5	
NF	Noise Figure at $V_{CE} = -10 \text{ V}$, $I_C = -3 \text{ mA}$	dB		2.0	3.0
$ S_{21E} ^2$	Insertion Power Gain at $V_{CE} = -10 \text{ V}$, $I_C = -15 \text{ mA}$, $f = 1 \text{ GHz}$	dB	8.0	10.0	
h_{FE}	Forward Current Gain Ratio at $V_{CE} = -10 \text{ V}$, $I_C = -15 \text{ mA}$		20	40	100
I_{CBO}	Collector Cutoff Current at $V_{CB} = -10 \text{ V}$, $I_E = 0$	μA			-0.1
I_{EBO}	Emitter Cutoff Current at $V_{BE} = -2 \text{ V}$, $I_C = 0$	μA			-0.1
C_{RE}^2	Feedback Capacitance at $V_{CB} = -10 \text{ V}$, $I_E = 0 \text{ mA}$, $f = 1 \text{ MHz}$	pF		0.5	1.0
P_T	Total Power Dissipation	mW			200

Notes:

1. Electronic Industrial Association of Japan.
2. Capacitance is measured with emitter and case connected to the guard terminal at the bridge.

ABSOLUTE MAXIMUM RATINGS¹ ($T_A = 25^\circ\text{C}$)

SYMBOLS	PARAMETERS	UNITS	RATINGS
V _{CBO}	Collector to Base Voltage	V	-20
V _{CEO}	Collector to Emitter Voltage	V	-12
V _{EBO}	Emitter to Base Voltage	V	-3
I _C	Collector Current	mA	-50
T _J	Junction Temperature	°C	150
T _{STG}	Storage Temperature	°C	-65 to +200

Note:

1. Operation in excess of any one of these parameters may result in permanent damage.

TYPICAL PERFORMANCE CURVES ($T_A = 25^\circ\text{C}$)

DC CURRENT GAINS vs. COLLECTOR CURRENT

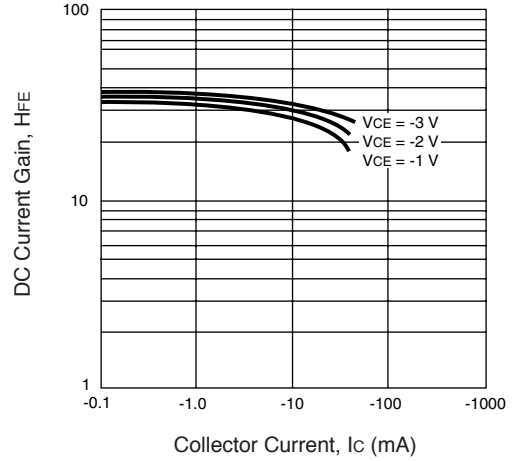

DC POWER DERATING CURVES

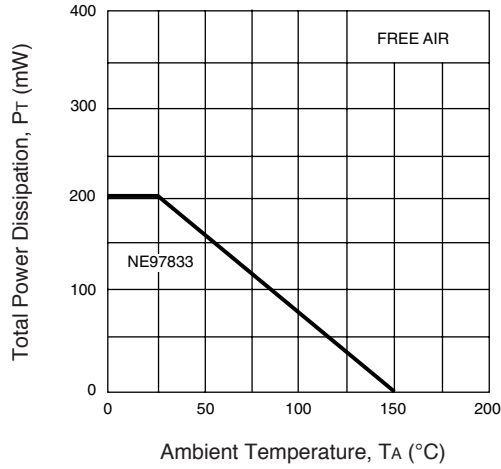

INSERTION GAIN vs. FREQUENCY

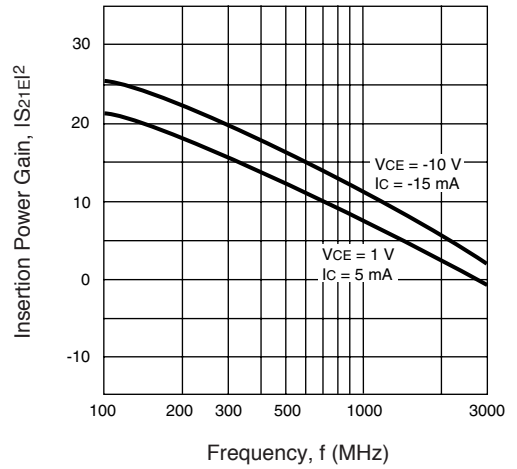

GAIN BANDWIDTH vs. COLLECTOR CURRENT

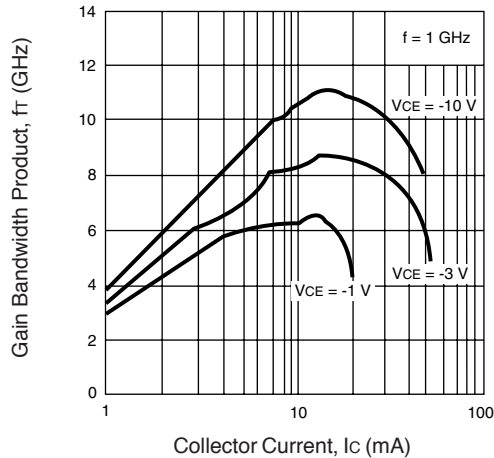

INSERTION GAIN vs. COLLECTOR CURRENT

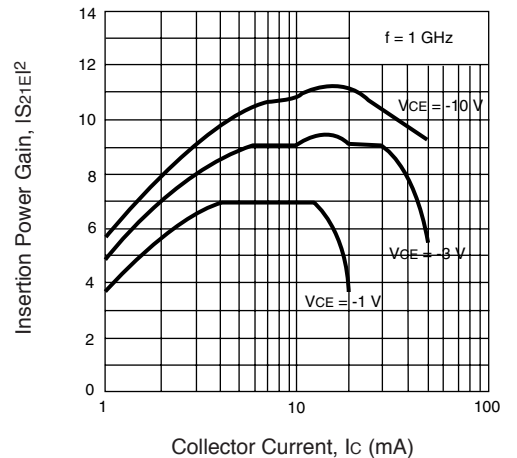

TYPICAL PERFORMANCE CURVES ($T_A = 25^\circ\text{C}$)

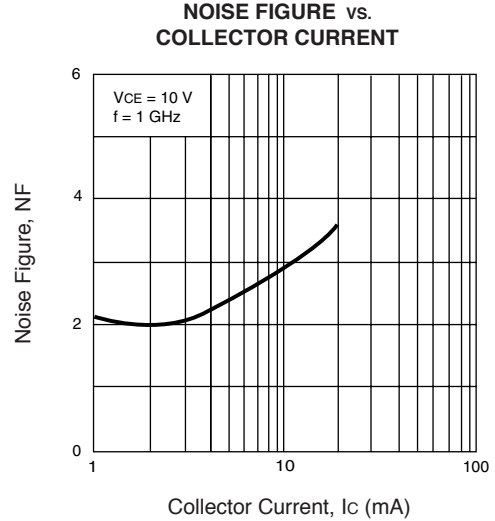
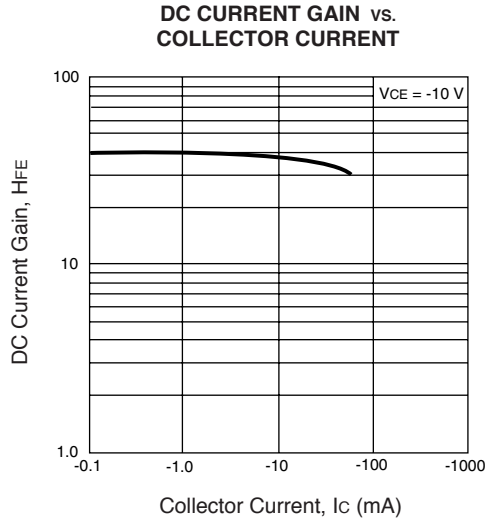

SWITCHING CHARACTERISTICS

UNITS	PARAMETERS	UNITS	$V_{IN} = 1\text{ V}$
			TYP
t_{ON} (delay)	Turn-on Delay Time	ns	1.10
t_r	Rise Time	ns	0.77
t_{OFF} (delay)	Turn-off Delay Time	ns	0.40
t_f	Fall Time	ns	0.79

SWITCHING TIME MEASUREMENT CIRCUIT

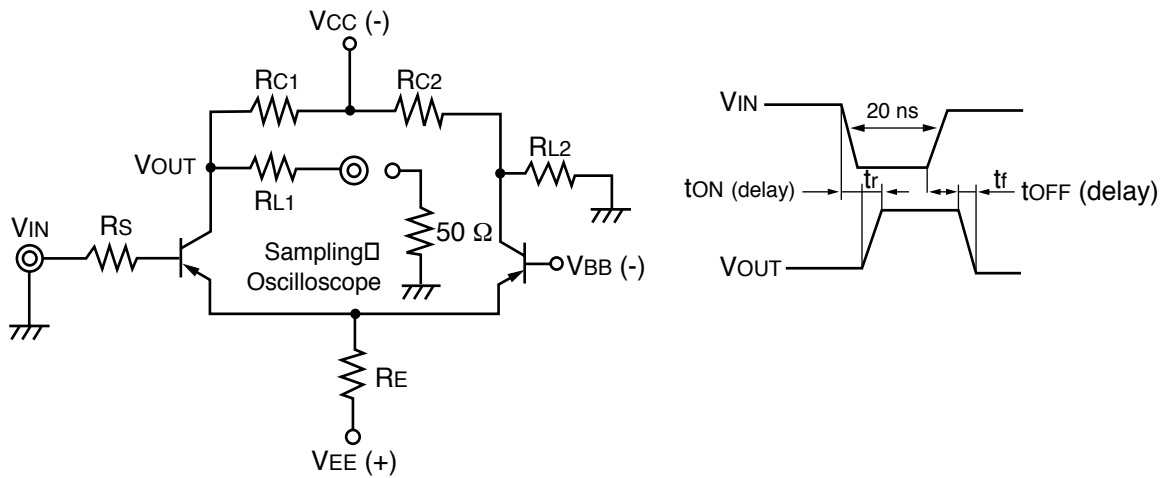

$V_{IN} = 1\text{ v}, V_{BB} = -0.5\text{ V}, R_{C1} = R_{C2}$						
R_S (Ω)	R_C (Ω)	R_{L1} (Ω)	R_{L2} (Ω)	R_E (Ω)	V_{EE} (V)	V_{CC} (V)
160	1 K	200	250	2.7 K	27	26.3

TYPICAL SCATTERING PARAMETERS (T_A = 25°C)

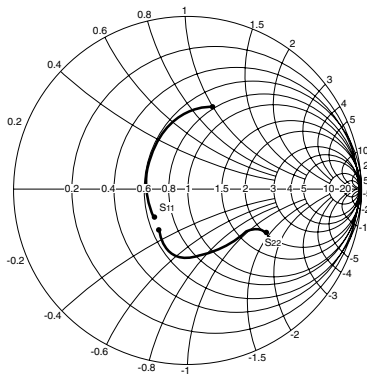

NE97833
VCE = -8 V, Ic = -10 mA

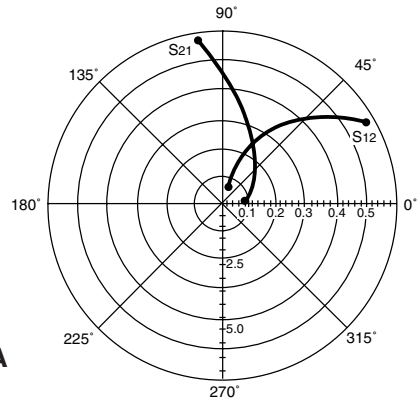

VCE = -5 V, Ic = -10 mA

FREQUENCY (GHz)	S11		S21		S12		S22		K	MAG ¹ (dB)
	MAG	ANG	MAG	ANG	MAG	ANG	MAG	ANG		
0.50	0.274	-149.2	6.102	96.9	0.063	68.1	0.493	-30.9	0.97	19.9
0.80	0.273	-177.0	4.037	82.0	0.093	70.1	0.432	-32.2	1.07	14.7
1.00	0.278	169.8	3.303	74.5	0.114	70.3	0.412	-34.5	1.09	12.8
1.50	0.308	144.6	2.311	58.7	0.170	68.1	0.381	-44.8	1.08	9.6
2.00	0.352	125.0	1.808	45.3	0.229	63.9	0.362	-59.4	1.03	7.8
2.50	0.402	109.1	1.496	33.5	0.288	58.3	0.359	-75.9	0.99	7.2
3.00	0.449	96.4	1.281	23.6	0.345	52.4	0.364	-91.0	0.95	5.7
4.00	0.506	79.7	1.023	9.1	0.458	40.7	0.350	-113.5	0.91	3.5
5.00	0.527	71.1	0.908	-1.8	0.574	27.4	0.246	-138.8	0.92	2.0

VCE = -8 V, Ic = -10 mA

0.50	0.252	-140.2	6.426	98.5	0.060	68.7	0.523	-29.0	0.95	20.3
0.80	0.240	-171.6	4.270	83.5	0.089	70.6	0.463	-30.1	1.05	15.4
1.00	0.243	173.7	3.496	76.0	0.109	70.9	0.443	-32.3	1.08	13.4
1.50	0.272	145.9	2.445	60.5	0.162	60.5	0.515	-43.9	1.11	9.8
2.00	0.316	125.3	1.911	47.2	0.219	65.0	0.393	-55.2	1.02	8.4
2.50	0.369	109.0	1.582	35.6	0.276	59.8	0.388	-70.6	0.98	7.6
3.00	0.418	96.4	1.353	25.5	0.333	54.2	0.392	-85.0	0.94	6.1
4.00	0.479	79.9	1.076	10.7	0.445	42.9	0.379	-106.3	0.90	3.8
5.00	0.503	71.7	0.950	-0.4	0.563	30.2	0.278	-127.3	0.90	2.3

VCE = -10 V, Ic = -15 mA

0.50	0.555	-80.8	4.097	116.8	0.076	55.1	0.697	-28.4	0.65	17.3
0.80	0.399	-121.8	3.325	94.8	0.094	53.5	0.600	-32.6	0.89	15.5
1.00	0.348	-143.5	2.864	84.2	0.106	55.4	0.564	-35.2	1.00	14.3
1.50	0.314	173.5	2.107	64.5	0.140	69.0	0.411	-39.4	1.07	10.2
2.00	0.342	142.8	1.669	49.0	0.186	62.8	0.494	-56.1	1.08	7.8
2.50	0.393	120.2	1.382	36.0	0.241	61.5	0.490	-70.2	1.00	7.4
3.00	0.446	103.4	1.179	25.6	0.302	57.9	0.496	-83.7	0.93	5.9
4.00	0.515	81.7	0.934	11.9	0.433	47.8	0.484	-105.8	0.87	3.3
5.00	0.529	69.6	0.844	3.0	0.575	34.3	0.382	-128.7	0.90	1.7

VCE = -10 V, Ic = -3 mA

0.50	0.214	-153.1	6.846	96.2	0.058	73.2	0.506	-27.0	0.99	20.7
0.80	0.215	179.7	4.489	82.4	0.087	74.0	0.456	-27.9	1.06	15.6
1.00	0.221	166.8	3.664	75.4	0.108	73.7	0.439	-30.1	1.07	13.7
1.50	0.254	141.5	2.554	60.6	0.163	70.6	0.441	-41.8	1.05	10.6
2.00	0.300	122.3	1.992	47.7	0.220	66.0	0.393	-52.7	1.01	8.9
2.50	0.352	107.1	1.648	36.2	0.276	60.4	0.387	-68.0	0.97	7.8
3.00	0.402	95.0	1.410	26.3	0.331	54.6	0.389	-82.1	0.94	6.3
4.00	0.463	79.5	1.121	11.3	0.440	43.4	0.377	-102.6	0.89	4.1
5.00	0.489	72.1	0.984	-0.2	0.555	31.0	0.277	-121.3	0.89	2.5

Note:

1. Gain Calculation:

$$MAG = \frac{|S_{21}|}{|S_{12}|} (K \pm \sqrt{K^2 - 1}). \text{ When } K \leq 1, \text{ MAG is undefined and MSG values are used. } MSG = \frac{|S_{21}|}{|S_{12}|}, K = \frac{1 + |\Delta|^2 - |S_{11}|^2 - |S_{22}|^2}{2 |S_{12}| |S_{21}|}, \Delta = S_{11} S_{22} - S_{21} S_{12}$$

MAG = Maximum Available Gain
MSG = Maximum Stable Gain

OUTLINE DIMENSIONS (Units in mm)

PACKAGE OUTLINE 33
(SOT-23)

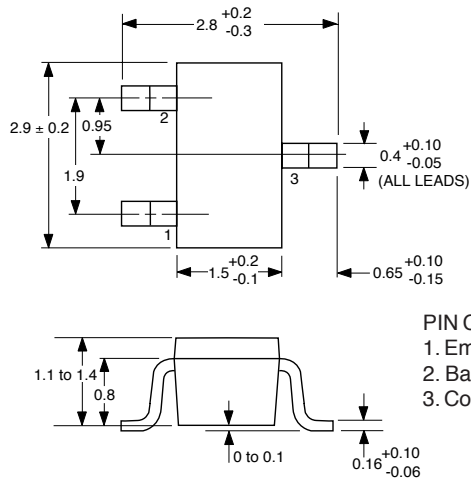

OUTLINE 33
RECOMMENDED P.C.B. LAYOUT

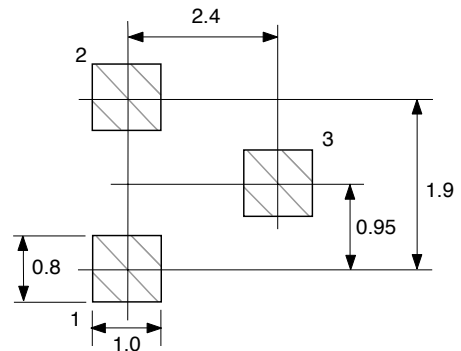

ORDERING INFORMATION

PART NUMBER	QUANTITY	PACKAGING
NE97833-T1B-A	3000	Tape & Reel

EXCLUSIVE NORTH AMERICAN AGENT FOR RF, MICROWAVE & OPTOELECTRONIC SEMICONDUCTORS

CEL CALIFORNIA EASTERN LABORATORIES • Headquarters • 4590 Patrick Henry Drive • Santa Clara, CA 95054-1817 • (408) 988-3500 • Telex 34-6393 • FAX (408) 988-0279
 24-Hour Fax-On-Demand: 800-390-3232 (U.S. and Canada only) • Internet: <http://WWW.CEL.COM>

DATA SUBJECT TO CHANGE WITHOUT NOTICE

PRINTED IN USA ON RECYCLED PAPER -7/98