

# NX7537BF-AA

## Data Sheet

LASER DIODE

R08DS0006EJ0400

Rev.4.00

1 550 nm InGaAsP MQW-FP LASER DIODE COAXIAL MODULE FOR OTDR APPLICATION

Feb 28, 2011

### DESCRIPTION

The NX7537BF-AA is a 1 550 nm Multiple Quantum Well (MQW) structured Fabry-Perot (FP) laser diode coaxial module with single mode fiber. This module is specified to operate under pulsed condition and designed for light source of Optical Time Domain Reflectometer (OTDR).

### FEATURES

- High output power       $P_r = 120 \text{ mW MIN. @ } I_{FP} = 1\,000 \text{ mA}^{*1}$
- Long wavelength       $\lambda_c = 1\,550 \text{ nm}$

\*1 Pulse Conditions: Pulse width (PW) = 10  $\mu\text{s}$ , Duty = 1%



The mark <R> shows major revised points.

The revised points can be easily searched by copying an "<R>" in the PDF file and specifying it in the "Find what:" field.

<R> **PACKAGE DIMENSIONS (UNIT: mm)**

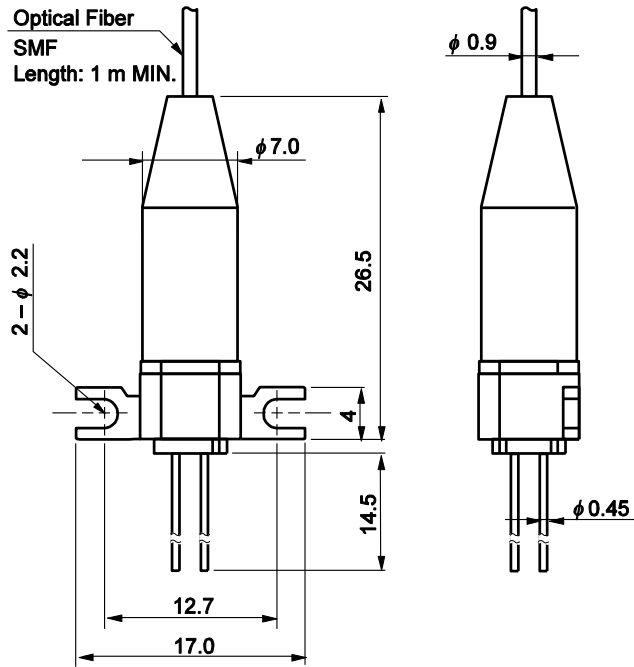

**PIN CONNECTIONS**

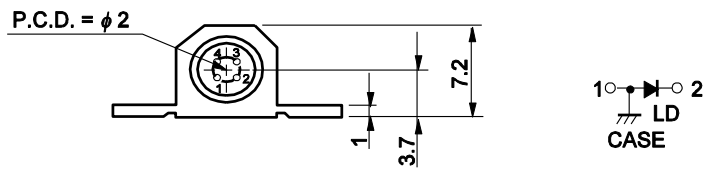

## OPTICAL FIBER CHARACTERISTICS

Parameter	Specification	Unit
Mode Field Diameter	9.3±0.5	μm
Cladding Diameter	125±2	μm
Maximum Cladding Noncircularity	2	%
Maximum Core/Cladding Concentricity	1.6	%
Outer Diameter	0.9±0.1	mm
Cut-off Wavelength	1 140 to 1 280	nm
Minimum Fiber Bending Radius	30	mm
Fiber Length	1 000 MIN.	mm

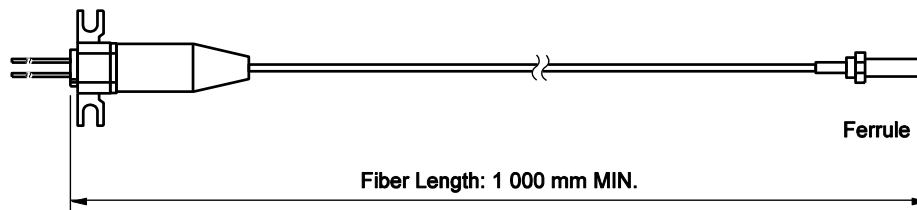

## ORDERING INFORMATION

Part Number	Flange Type	Pf (MIN.)
NX7537BF-AA	flat mount flange	120

## ABSOLUTE MAXIMUM RATINGS (T<sub>c</sub> = 25°C, unless otherwise specified)

Parameter	Symbol	Ratings	Unit
Pulsed Forward Current <sup>*1</sup>	I <sub>FP</sub>	1.2	A
Reverse Voltage	V <sub>R</sub>	2.0	V
Operating Case Temperature	T <sub>c</sub>	-20 to +60	°C
Storage Temperature	T <sub>stg</sub>	-40 to +85	°C
Lead Soldering Temperature	T <sub>slid</sub>	350 (3 sec.)	°C
Relative Humidity (noncondensing)	RH	85	%

\*1 Pulse Condition: Pulse Width (PW) = 10 μs, Duty = 1%

## ELECTRO-OPTICAL CHARACTERISTICS (T<sub>c</sub> = 25°C)

Parameter	Symbol	Conditions	MIN.	TYP.	MAX.	Unit
Forward Voltage	V <sub>FP</sub>	I <sub>FP</sub> = 1 000 mA, PW = 10 μs, Duty = 1%		2.5	4.0	V
Threshold Current	I <sub>th</sub>			45	75	mA
Optical Output Power from Fiber	P <sub>f</sub>	I <sub>FP</sub> = 1 000 mA, PW = 10 μs, Duty = 1%	120	145		mW
Center Wavelength	λ <sub>c</sub>	RMS (-20 dB), I <sub>FP</sub> = 1 000 mA, PW = 10 μs, Duty = 1%	1 530	1 550	1 570	nm
Spectral Width	σ	RMS (-20 dB), I <sub>FP</sub> = 1 000 mA, PW = 10 μs, Duty = 1%		7.5	10.0	nm
Rise Time	t <sub>r</sub>	10-90%			2.0	ns
Fall Time	t <sub>f</sub>	90-10%			2.0	ns

## ELECTRO-OPTICAL CHARACTERISTICS (T<sub>c</sub> = 0 to +60°C)

Parameter	Symbol	Conditions	MIN.	TYP.	MAX.	Unit
Threshold Current	I <sub>th</sub>				100	mA
Optical Output Power from Fiber	P <sub>f</sub>	I <sub>FP</sub> = 1000 mA, PW = 10 μs, Duty = 1%	60			mW
Center Wavelength	λ <sub>c</sub>	RMS (-20 dB), I <sub>FP</sub> = 1 000 mA, PW = 10 μs, Duty = 1%	1 520		1 585	nm
Temperature Dependency of Center Wavelength	Δλ/ΔT			0.35		nm/°C
Spectral Width	σ	RMS (-20 dB), I <sub>FP</sub> = 1 000 mA, PW = 10 μs, Duty = 1%			10	nm

**TYPICAL CHARACTERISTICS (T<sub>c</sub> = 25°C, unless otherwise specified)**

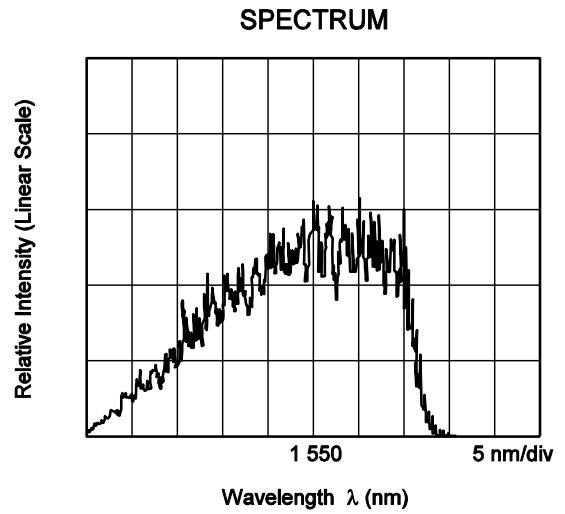
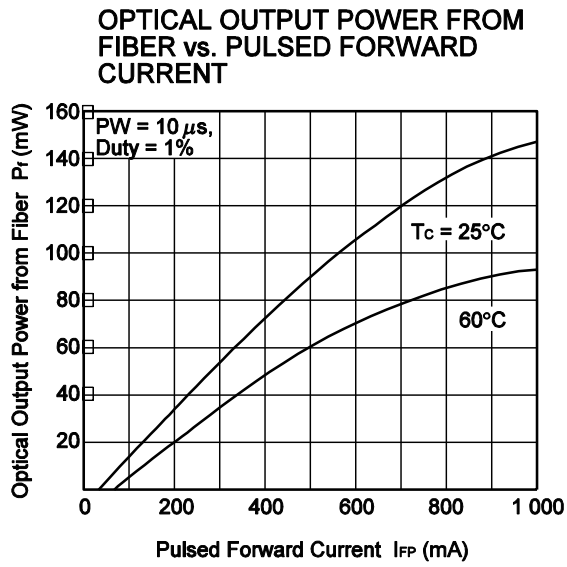

**Remark** The graphs indicate nominal characteristics.

## REFERENCE

Document Name	Document No.
Opto-Electronics Devices Pamphlet <sup>*1</sup>	PX10160E

\*1 Published by the former NEC Electronics Corporation.

**SAFETY INFORMATION ON THIS PRODUCT**



**SEMICONDUCTOR LASER**



<p><b>Warning</b> Laser Beam</p>	<p>A laser beam is emitted from this diode during operation. The laser beam, visible or invisible, directly or indirectly, may cause injury to the eye or loss of eyesight.</p> <ul style="list-style-type: none"> <li>• Do not look directly into the laser beam.</li> <li>• Avoid exposure to the laser beam, any reflected or collimated beam.</li> </ul>
<p><b>Caution</b> GaAs Products</p>	<p>This product uses gallium arsenide (GaAs). GaAs vapor and powder are hazardous to human health if inhaled or ingested, so please observe the following points.</p> <ul style="list-style-type: none"> <li>• Follow related laws and ordinances when disposing of the product. If there are no applicable laws and/or ordinances, dispose of the product as recommended below.             <ol style="list-style-type: none"> <li>1. Commission a disposal company able to (with a license to) collect, transport and dispose of materials that contain arsenic and other such industrial waste materials.</li> <li>2. Exclude the product from general industrial waste and household garbage, and ensure that the product is controlled (as industrial waste subject to special control) up until final disposal.</li> </ol> </li> <li>• Do not burn, destroy, cut, crush, or chemically dissolve the product.</li> <li>• Do not lick the product or in any way allow it to enter the mouth.</li> </ul>
<p><b>Caution</b> Optical Fiber</p>	<p>A glass-fiber is attached on the product. Handle with care.</p> <ul style="list-style-type: none"> <li>• When the fiber is broken or damaged, handle carefully to avoid injury from the damaged part or fragments.</li> </ul>

<b>Revision History</b>	<b>NX7537BF-AA Data Sheet</b>
-------------------------	-------------------------------

Rev.	Date	Description	
		Page	Summary
-	Jul 2006	-	Previous No. : PL10605EJ02V0DS
3.00	Sep 19, 2010	p.1	Modification of photograph
		p.2, 3	Modification of <b>PACKAGE DIMENSIONS</b>
4.00	Feb 28, 2011	p.2	Modification of <b>PACKAGE DIMENSIONS</b> : MMF -> SMF

All trademarks and registered trademarks are the property of their respective owners.