

NX8601BF-AA

Data Sheet

LASER DIODE

R08DS0109EJ0100

Rev.1.00

1 625 nm InGaAsP MQW-DFB LASER DIODE COAXIAL MODULE FOR OTDR APPLICATION

Apr 19, 2013

DESCRIPTION

The NX8601BF-AA is a 1 625 nm Multiple Quantum Well (MQW) structured Distributed Feed-Back (DFB) pulsed laser diode coaxial module with single mode fiber. This module is specified to operate under pulsed condition and designed for light source of Optical Time Domain Reflectometer (OTDR).

FEATURES

- Distributed Feed-Back (DFB) pulsed laser diode
- High output power $P_f = 80 \text{ mW}$ @ $I_{FP} = 450 \text{ mA}$, $PW = 10 \mu\text{s}$, Duty = 1%
- Wavelength $\lambda_p = 1 \text{ 625 nm}$
- Single mode fiber pigtail



PACKAGE DIMENSIONS (UNIT: mm)

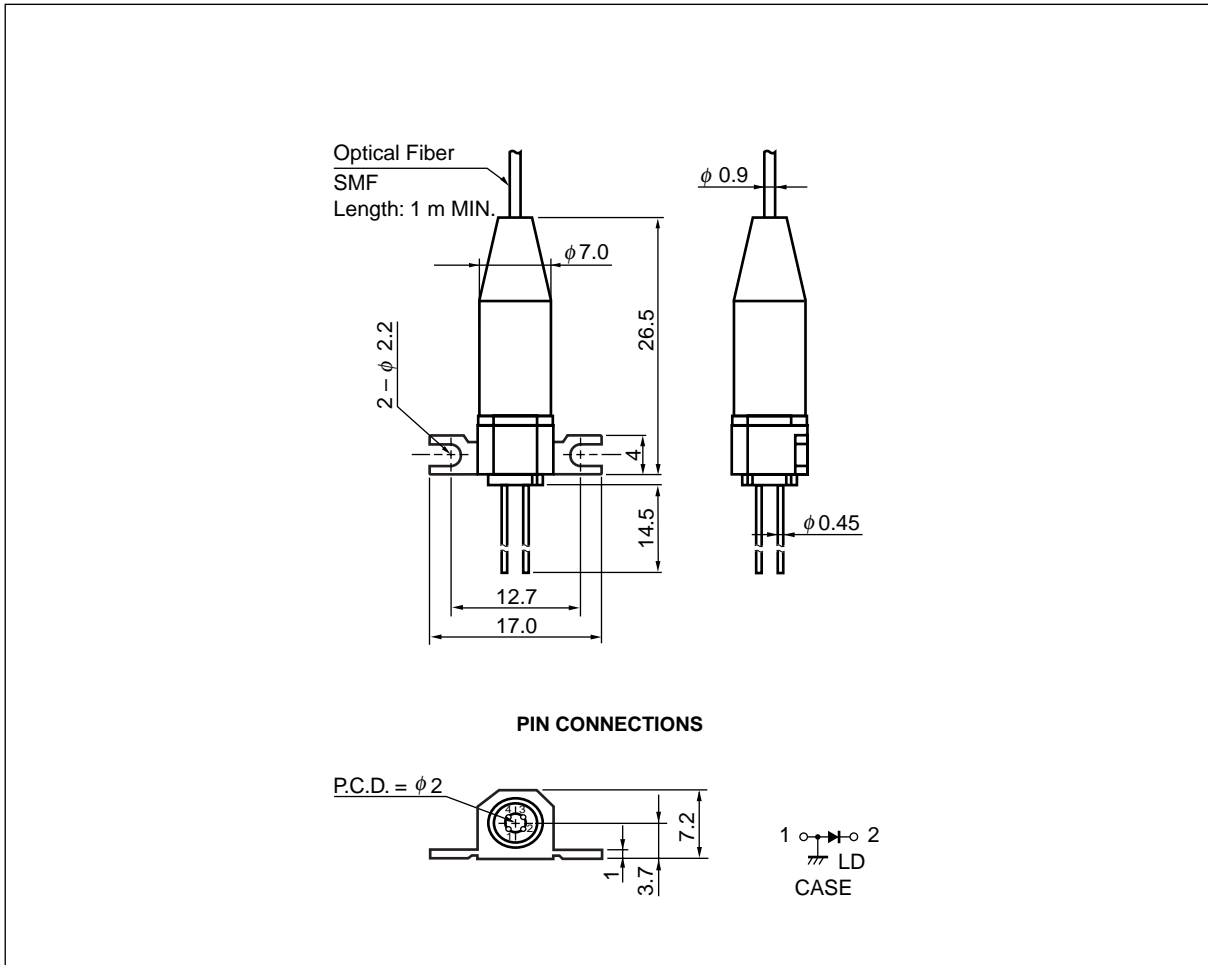

OPTICAL FIBER CHARACTERISTICS

Parameter	Specification	Unit
Mode Field Diameter	9.3 \pm 0.5	μ m
Cladding Diameter	125 \pm 2	μ m
Maximum Cladding Non-circularity	2	%
Maximum Core/Cladding Concentricity	1.6	%
Outer Diameter	0.9 \pm 0.1	mm
Minimum Fiber Bending Radius	30	mm
Fiber Length	1 000 MIN.	mm

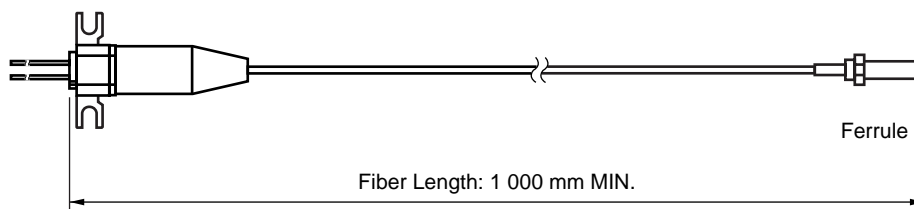

ORDERING INFORMATION

Part Number	Flange Type
NX8601BF-AA-AZ	flat mount flange

ABSOLUTE MAXIMUM RATINGS ($T_A = 25^\circ\text{C}$, unless otherwise specified)

Parameter	Symbol	Ratings	Unit
Pulsed Forward Current ^{*1}	I_{FP}	600	mA
Reverse Voltage	V_R	2.0	V
Operating Case Temperature	T_C	0 to +60	$^\circ\text{C}$
Storage Temperature	T_{stg}	-40 to +85	$^\circ\text{C}$
Lead Soldering Temperature	T_{sld}	350 (3 sec.)	$^\circ\text{C}$
Relative Humidity (noncondensing)	RH	85	%

Note: *1 Pulse Condition: Pulse Width (PW) = 10 μs , Duty = 1%

ELECTRO-OPTICAL CHARACTERISTICS ($T_C = 25^\circ\text{C}$, unless otherwise specified)

Parameter	Symbol	Conditions	MIN.	TYP.	MAX.	Unit
Forward Voltage	V_{FP}	$I_{FP} = 450\text{ mA}$, $PW = 10\ \mu\text{s}$, Duty = 1%		-	3.0	V
Threshold Current	I_{th}	CW		20	60	mA
Optical Output Power from Fiber	P_f	$I_{FP} = 450\text{ mA}$, $PW = 10\ \mu\text{s}$, Duty = 1%	50	80	-	mW
		$I_{FP} = 450\text{ mA}$, $PW = 10\ \mu\text{s}$, Duty = 1% $T_C = 0\text{ to }+60^\circ\text{C}$	25	-	-	
Center Wavelength	λ_p	$I_{FP} = 450\text{ mA}$, $PW = 10\ \mu\text{s}$, Duty = 1%	1 620	1 625	1 630	nm

SAFETY INFORMATION ON THIS PRODUCT

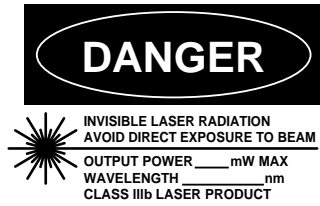

SEMICONDUCTOR LASER

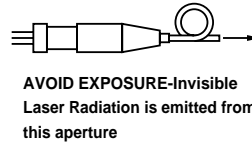

<p>Warning Laser Beam</p>	<p>A laser beam is emitted from this diode during operation. The laser beam, visible or invisible, directly or indirectly, may cause injury to the eye or loss of eyesight.</p> <ul style="list-style-type: none"> • Do not look directly into the laser beam. • Avoid exposure to the laser beam, any reflected or collimated beam.
<p>Caution GaAs Products</p>	<p>This product uses gallium arsenide (GaAs). GaAs vapor and powder are hazardous to human health if inhaled or ingested, so please observe the following points.</p> <ul style="list-style-type: none"> • Follow related laws and ordinances when disposing of the product. If there are no applicable laws and/or ordinances, dispose of the product as recommended below. <ol style="list-style-type: none"> 1. Commission a disposal company able to (with a license to) collect, transport and dispose of materials that contain arsenic and other such industrial waste materials. 2. Exclude the product from general industrial waste and household garbage, and ensure that the product is controlled (as industrial waste subject to special control) up until final disposal. • Do not burn, destroy, cut, crush, or chemically dissolve the product. • Do not lick the product or in any way allow it to enter the mouth.
<p>Caution Optical Fiber</p>	<p>A glass-fiber is attached on the product. Handle with care.</p> <ul style="list-style-type: none"> • When the fiber is broken or damaged, handle carefully to avoid injury from the damaged part or fragments.

Revision History	NX8601BF-AA Data Sheet
-------------------------	-------------------------------

Rev.	Date	Description	
		Page	Summary
1.00	Apr 19, 2013	-	First edition issued

All trademarks and registered trademarks are the property of their respective owners.