

PS9309L, PS9309L2

Preliminary Data Sheet

Specifications in this document are tentative and subject to change.

–NEPOC Series–

March 3, 2011

Low Input Current TOTEM POLE OUTPUT TYPE HIGH CMR, IPM DRIVER, 6-PIN SDIP PHOTOCOUPLER

DESCRIPTION

The PS9309L and PS9309L2 are optical coupled high-speed, totem pole output (active high output type) isolators containing a GaAlAs LED on the input side and a photodiode and a signal processing circuit on the output side on one chip.

The PS9309L and PS9309L2 are specified high CMR and pulse width distortion with operating temperature. It is suitable for IPM drive.

The PS9309L is lead bending type (Gull-wing) for surface mounting.

The PS9309L2 is lead bending type for long creepage distance (Gull-wing) for surface mount.

FEATURES

- High common mode transient immunity ($CM_H, CM_L = \pm 15 \text{ kV}/\mu\text{s}$ MIN.)
- Half size of 8-pin DIP
- Pulse width distortion ($t_{PLH} - t_{PHL} = 220 \text{ ns}$ MAX.)
- High isolation voltage ($BV = 5\,000 \text{ V}_{r.m.s.}$)
- Totem pole output (Active High Output Type)
- Embossed tape product : PS9309L-E3 : 2 000 pcs/reel
 : PS9309L2-E3: 2 000 pcs/reel
- Pb-Free product

APPLICATIONS

- IPM Driver
- General purpose inverter

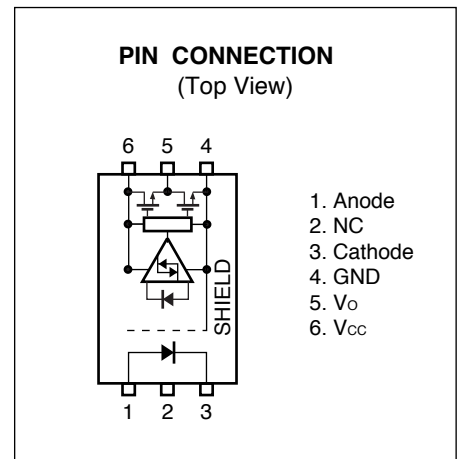

TRUTH TABLE

LED	Output
ON	H
OFF	L

PACKAGE DIMENSIONS (UNIT: mm)

Lead Bending Type (Gull-wing) For Surface Mount

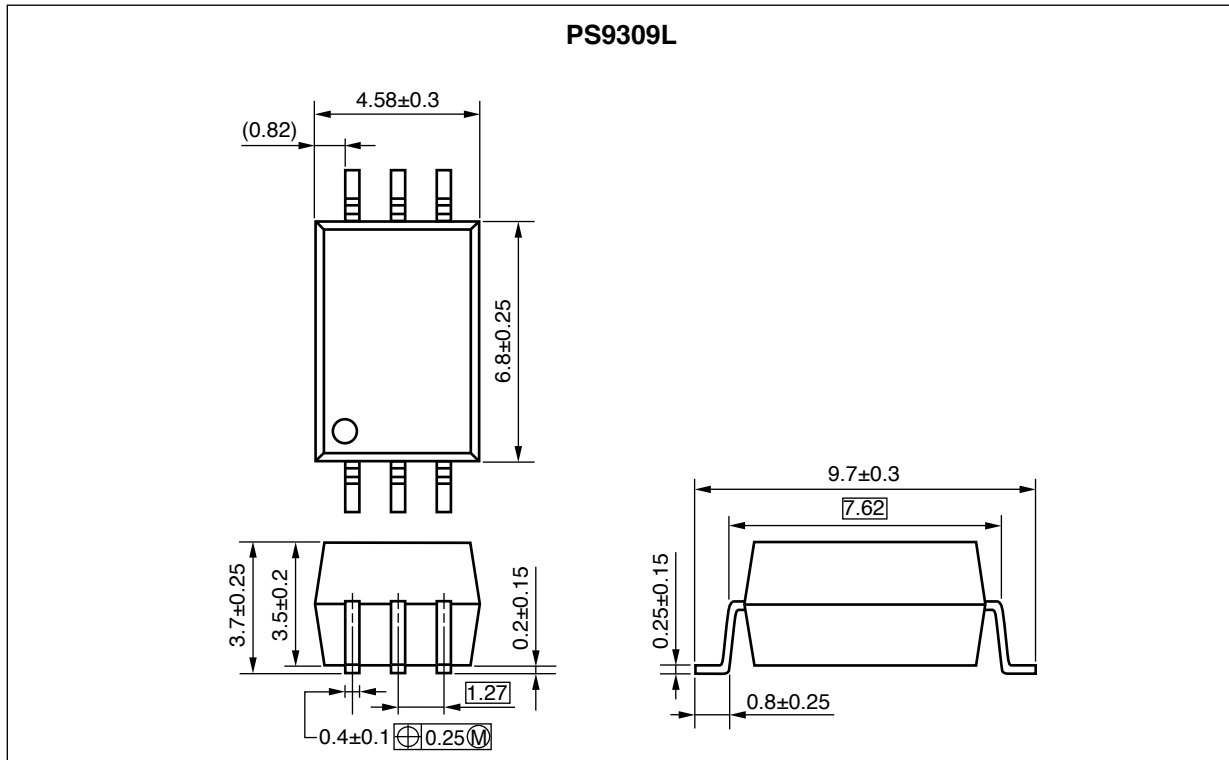

Lead Bending Type (Gull-wing) For Long Creepage Distance (Surface Mount)

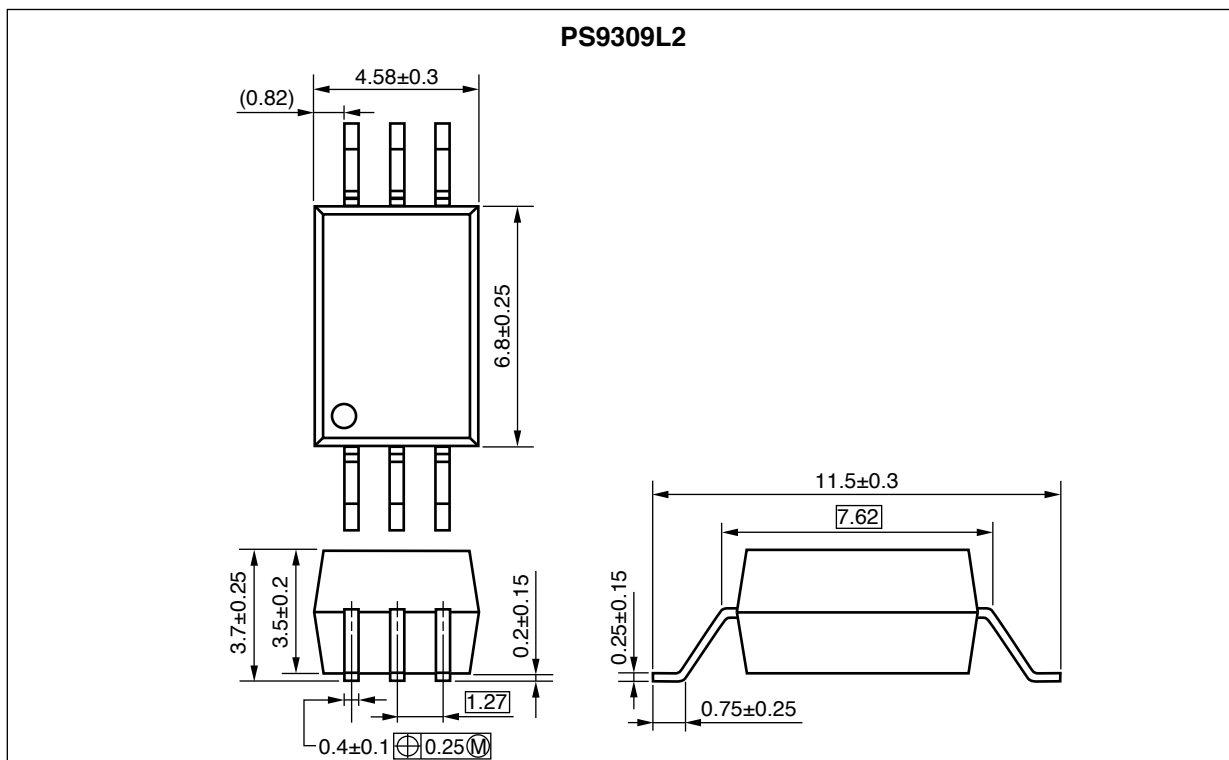

PHOTOCOUPLER CONSTRUCTION

Parameter	PS9309L	PS9309L2
Air Distance (MIN.)	7 mm	8 mm
Outer Creepage Distance (MIN.)	7 mm	8 mm
Isolation Distance (MIN.)	0.4 mm	0.4 mm

MARKING EXAMPLE

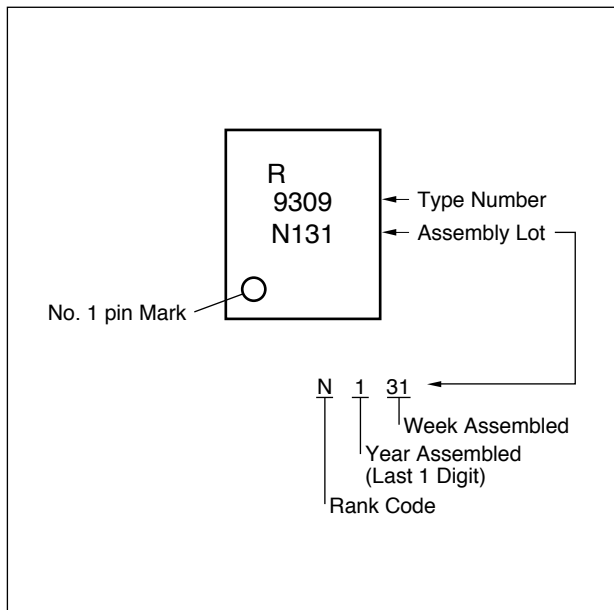

ORDERING INFORMATION

Part Number	Order Number	Solder Plating Specification	Packing Style	Application Part Number ^{*1}
PS9309L	PS9309L-AX	Pb-Free (Ni/Pd/Au)	20 pcs (Tape 20 pcs cut)	PS9309L
PS9309L-E3	PS9309L-E3-AX		Embossed Tape 2 000 pcs/reel	
PS9309L2	PS9309L2-AX		20 pcs (Tape 20 pcs cut)	PS9309L2
PS9309L2-E3	PS9309L2-E3-AX		Embossed Tape 2 000 pcs/reel	
PS9309L-V	PS9309L-V-AX		20 pcs (Tape 20 pcs cut)	PS9309L
PS9309L-V-E3	PS9309L-V-E3-AX		Embossed Tape 2 000 pcs/reel	
PS9309L2-V	PS9309L2-V-AX		20 pcs (Tape 20 pcs cut)	PS9309L2
PS9309L2-V-E3	PS9309L2-V-E3-AX		Embossed Tape 2 000 pcs/reel	

Note: *1. For the application of the Safety Standard, following part number should be used.

ABSOLUTE MAXIMUM RATINGS (T_A = 25°C, unless otherwise specified)

Parameter		Symbol	Ratings	Unit
Diode	Forward Current	I _F	20	mA
	Reverse Voltage	V _R	5	V
Detector	Supply Voltage	V _{CC}	-0.5 to +20	V
	Output Voltage	V _O	-0.5 to +20	V
	Output Current	I _O	25	mA
	Power Dissipation ^{*2}	P _C	210	mW
Isolation Voltage ^{*4}		BV	5 000	Vr.m.s.
Operating Ambient Temperature		T _A	-40 to +110	°C
Storage Temperature		T _{stg}	-55 to +125	°C

Notes: *1. Reduced to 0.5 mW/°C at T_A = 70°C or more.

*2. Reduced to 3.88 mW/°C at T_A = 70°C or more

*3. AC voltage for 1 minute at T_A = 25°C, RH = 60% between input and output.

Pins 1-3 shorted together, 4-6 shorted together.

RECOMMENDED OPERATING CONDITIONS

Parameter	Symbol	MIN.	TYP.	MAX.	Unit
Supply Voltage	V _{CC}	4.5	15	20	V
Output Voltage	V _O	0		20	V
Forward Current (ON)	I _{F (ON)}	4		10	mA
Forward Voltage (OFF)	V _{F (OFF)}	0		0.8	V

ELECTRICAL CHARACTERISTICS

($T_A = -40$ to $+110^\circ\text{C}$, $V_{CC} = 4.5$ to 20 V, unless otherwise specified)

Parameter		Symbol	Conditions	MIN.	TYP. ^{*1}	MAX.	Unit
Diode	Forward Voltage	V_F	$I_F = 10$ mA, $T_A = 25^\circ\text{C}$	1.3	1.55	1.8	V
	Reverse Current	I_R	$V_R = 3$ V, $T_A = 25^\circ\text{C}$			10	μA
	Input Capacitance	C_t	$V_F = 0$ V, $f = 1$ MHz, $T_A = 25^\circ\text{C}$		30		pF
Detector	High Level Output Voltage	V_{OH}	$V_{CC} = 4.5$ V, $I_O = -2.6$ mA, $I_F = 4$ mA	2.7			V
			$V_{CC} = 20$ V, $I_O = -2.6$ mA, $I_F = 4$ mA	17.4			
	Low Level Output Voltage ^{*2}	V_{OL}	$I_O = 3.5$ mA, $I_F = 0$ mA		0.2	0.6	V
	High Level Supply Current	I_{CCH}	$V_{CC} = 4.5$ V, $I_F = 4$ mA			3	mA
			$V_{CC} = 20$ V, $I_F = 4$ mA			3	
	Low Level Supply Current	I_{CCL}	$V_{CC} = 4.5$ V, $I_F = 0$ mA			3	mA
			$V_{CC} = 20$ V, $I_F = 0$ mA			3	
	High Level Output Short Circuit Current	I_{OSH}	$V_{CC} = 20$ V, $V_O = \text{GND}$, $I_F = 4$ mA	-7	-40		mA
Low Level Output Short Circuit Current	I_{OSL}	$V_{CC} = V_O = 20$ V, $V_F = 0$ V	7	40		mA	
Coupled	Threshold Input Current	I_{FLH}	$V_{CC} = 20$ V, $V_O > 2.7$ V, $I_O = -2.6$ mA			3	mA
	Isolation Resistance	R_{I-O}	$V_{I-O} = 500$ V _{DC} , RH = 60%, $T_A = 25^\circ\text{C}$	10^{12}			Ω
	Isolation Capacitance	C_{I-O}	$V = 0$ V, $f = 1$ MHz, $T_A = 25^\circ\text{C}$		0.6		pF
	Propagation Delay Time (H \rightarrow L) ^{*3}	t_{PHL}	$V_{CC} = 20$ V, $C_L = 15$ pF, $I_F = 4 \rightarrow 0$ mA, $V_{THHL} = 1.3$ V			250	ns
	Propagation Delay Time (L \rightarrow H) ^{*3}	t_{PLH}	$V_{CC} = 20$ V, $C_L = 15$ pF, $I_F = 0 \rightarrow 4$ mA, $V_{THLH} = 1.3$ V			250	ns
	Pulse Width Distortion (PWD)	$\Delta t_{PLH} - t_{PHL}$	$V_{CC} = 20$ V, $C_L = 15$ pF, $I_F = 4 \rightarrow 0$ mA			220	ns
	Maximum Propagation Delays						
	Rise Time (10-90%) ^{*3}	t_r	$V_{CC} = 20$ V, $C_L = 15$ pF, $I_F = 0 \rightarrow 4$ mA		30		ns
	Fall Time (90-10%) ^{*3}	t_f	$V_{CC} = 20$ V, $C_L = 15$ pF, $I_F = 4 \rightarrow 0$ mA		30		ns
	Common Mode Transient Immunity at High Level Output ^{*4}	CM_H	$V_{CC} = 5$ V, $T_A = 25^\circ\text{C}$, $I_F = 4$ mA, $\Delta V_{CM} = 1.0$ kV	15			kV/ μs
	Common Mode Transient Immunity at Low Level Output ^{*4}	CM_L	$V_{CC} = 5$ V, $T_A = 25^\circ\text{C}$, $I_F = 0$ mA, $\Delta V_{CM} = 1.0$ kV	15			kV/ μs

Notes: *1. Typical values at $T_A = 25^\circ\text{C}$

*2. Because V_O of 2.4 V may be output when the LED current is not input and when output supply of $V_{CC} = 4.5$ V or less, it is important to confirm the characteristics (operation with the power supply on and off) during design, before using this device.

***3. Test circuit for propagation delay time**

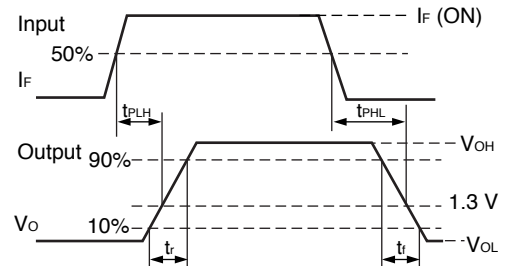
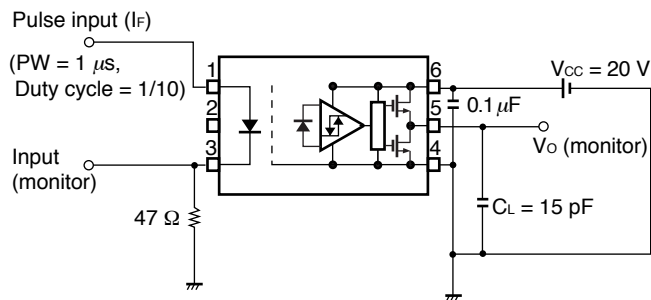

Remark C_L includes probe and stray wiring capacitance.

***4. Test circuit for common mode transient immunity**

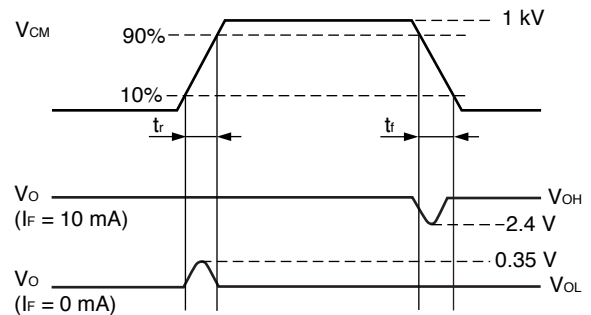
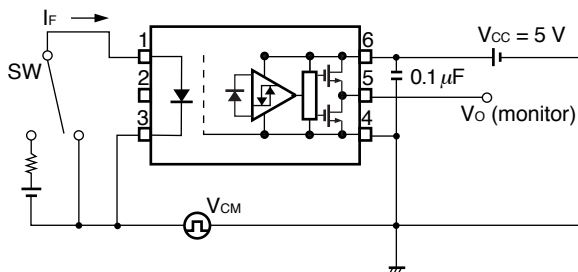

Remark C_L includes probe and stray wiring capacitance.

USAGE CAUTIONS

1. This product is weak for static electricity by designed with high-speed integrated circuit so protect against static electricity when handling.
2. By-pass capacitor of more than $0.1 \mu F$ is used between V_{CC} and GND near device. Also, ensure that the distance between the leads of the photocoupler and capacitor is no more than 10 mm.
3. Pin 2 (which is an NC*1 pin) can either be connected directly to the GND pin on the LED side or left open.
 Unconnected pins should not be used as a bypass for signals or for any other similar purpose because this may degrade the internal noise environment of the device.
 Note: *1. NC: Non-Connection (No Connection).
4. Avoid storage at a high temperature and high humidity.

TAPING SPECIFICATIONS (UNIT: mm)

Outline and Dimensions (Tape)

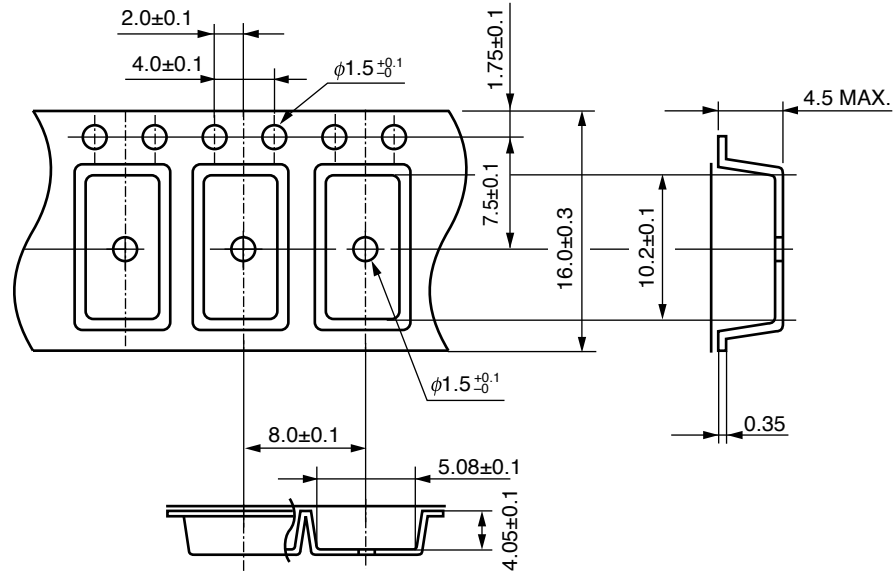

Tape Direction

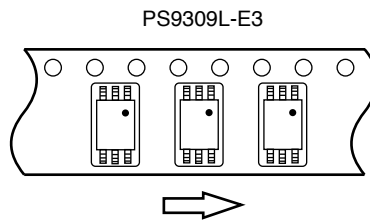

Outline and Dimensions (Reel)

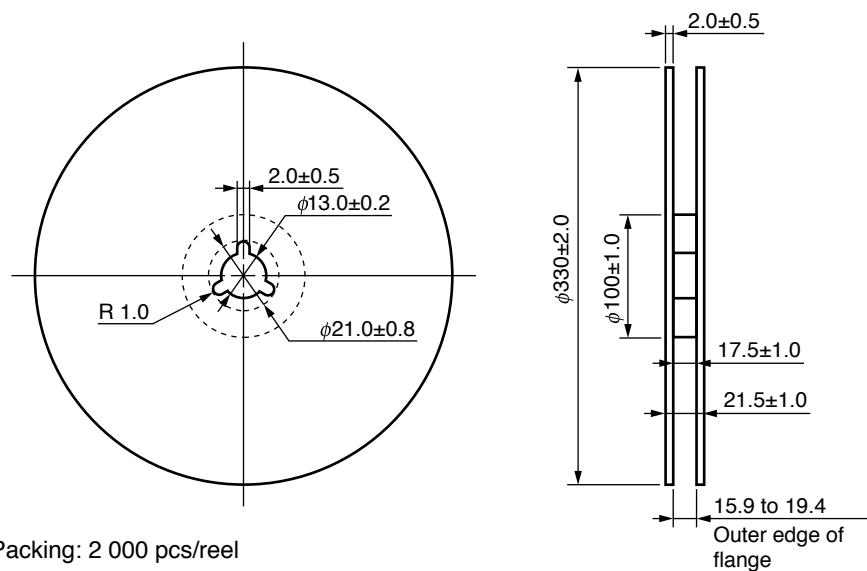

Outline and Dimensions (Tape)

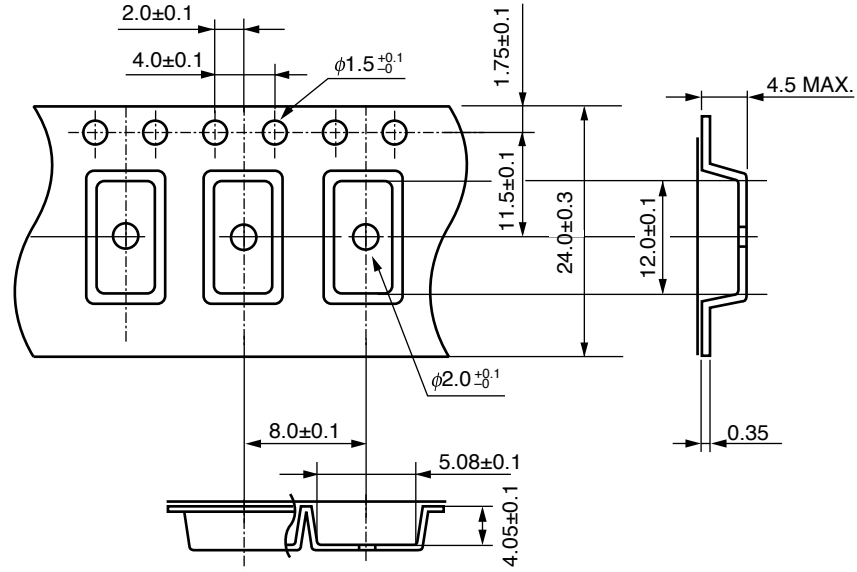

Tape Direction

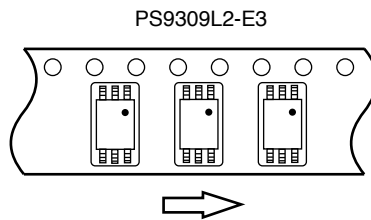

Outline and Dimensions (Reel)

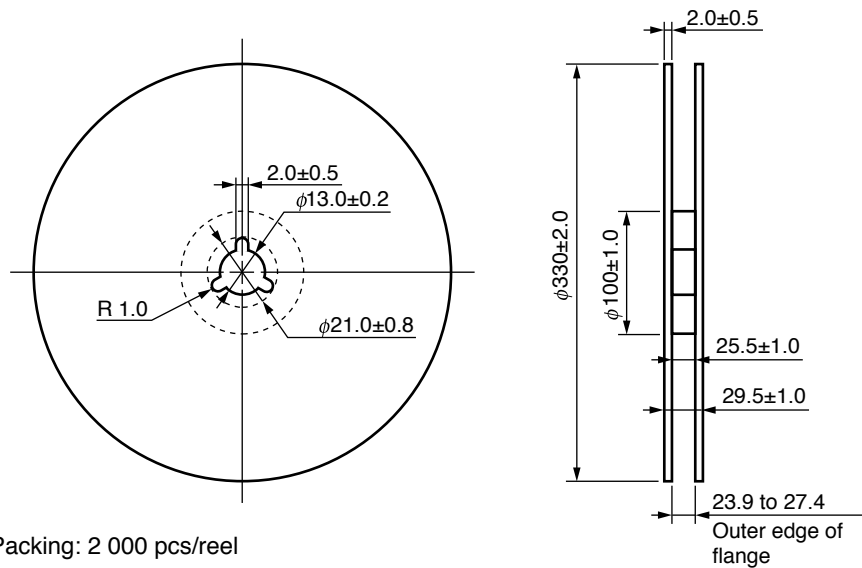

Caution	GaAs Products	<p>This product uses gallium arsenide (GaAs). GaAs vapor and powder are hazardous to human health if inhaled or ingested, so please observe the following points.</p> <ul style="list-style-type: none">• Follow related laws and ordinances when disposing of the product. If there are no applicable laws and/or ordinances, dispose of the product as recommended below. <ol style="list-style-type: none">1. Commission a disposal company able to (with a license to) collect, transport and dispose of materials that contain arsenic and other such industrial waste materials.2. Exclude the product from general industrial waste and household garbage, and ensure that the product is controlled (as industrial waste subject to special control) up until final disposal. <ul style="list-style-type: none">• Do not burn, destroy, cut, crush, or chemically dissolve the product.• Do not lick the product or in any way allow it to enter the mouth.
----------------	---------------	---