

D2E133-DM47-23

AC centrifugal fan

forward curved, dual inlet
with housing (flange)



ebm-papst Mulfingen GmbH & Co. KG

Bachmühle 2 · D-74673 Mulfingen

Phone +49 7938 81-0

Fax +49 7938 81-110

info1@de.ebmpapst.com

www.ebmpapst.com

Limited partnership · Headquarters Mulfingen
County court Stuttgart · HRA 590344

General partner Elektrobau Mulfingen GmbH · Headquarters Mulfingen
County court Stuttgart · HRB 590142



Nominal data

Type	D2E133-DM47-23		
Motor	M2E068-DF		
Phase		1~	1~
Nominal voltage	VAC	230	230
Frequency	Hz	50	60
Type of data definition		ml	ml
Valid for approval / standard		CE	CE
Speed	min ⁻¹	1650	2200
Power input	W	175	185
Current draw	A	0.78	0.82
Motor capacitor	µF	3	3
Capacitor voltage	VDB	450	450
Min. back pressure	Pa	100	250
Min. ambient temperature	°C	-25	-25
Max. ambient temperature	°C	40	40

ml = max. load · me = max. efficiency · fa = running at free air · cs = customer specs · cu = customer unit
Subject to alterations

Data according to ErP directive

Installation category	A
Efficiency category	Static
Variable speed drive	No
Specific ratio*	1.00

* Specific ratio = $1 + p_s / 100\,000\text{ Pa}$

	Actual	Request 2013	Request 2015
Overall efficiency η_{es}	25.5	25.3	32.3
Efficiency grade N	37.2	37	44
Power input P_e	kW	0.14	
Air flow q_v	m ³ /h	495	
Pressure increase p_{fs}	Pa	270	
Speed n	min ⁻¹	2295	

Data established at point of optimum efficiency



AC centrifugal fan

forward curved, dual inlet
with housing (flange)

Technical features

Mass	4. kg
Size	133 mm
Surface of rotor	Partially cast in aluminium
Material of impeller	Sheet steel, hot-galvanised
Housing material	Sheet steel, hot-galvanised
Motor suspension	Motor mounted via brackets on one side
Direction of rotation	Clockwise, seen on rotor
Type of protection	IP 44; Depending on installation and position
Insulation class	"B"
Humidity class	F0
Max. permissible ambient motor temp. (transp./ storage)	+ 80 °C
Min. permissible ambient motor temp. (transp./storage)	- 40 °C
Mounting position	Any
Condensate discharge holes	None
Operation mode	S1
Motor bearing	Ball bearing
Touch current acc. IEC 60990 (measuring network Fig. 4, TN system)	< 0.75 mA
Motor protection	Thermal overload protector (TOP) wired internally
Cable exit	Axial
Protection class	I (if protective earth is connected by customer)
Product conforming to standard	EN 60335-1; CE
Approval	CCC; GOST



D2E133-DM47-23

AC centrifugal fan

forward curved, dual inlet
with housing (flange)

Product drawing

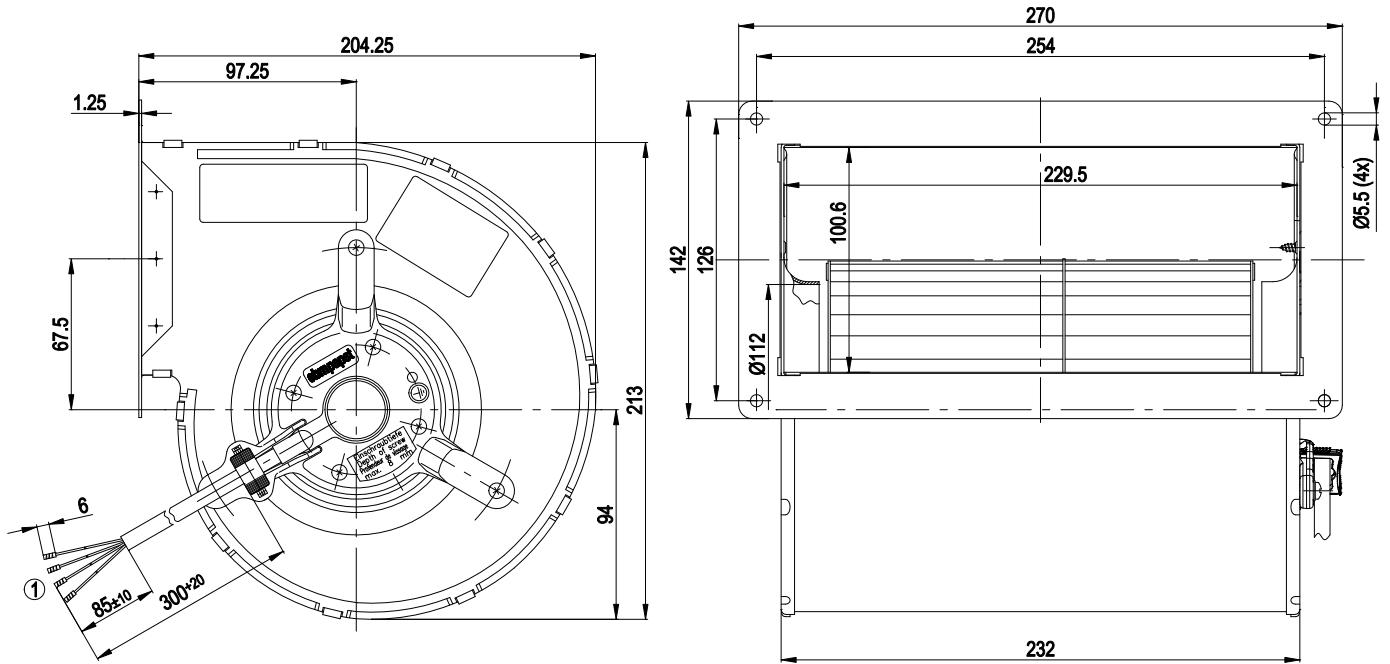

1 Connection line PVC 0.5mm², 4x brass lead tips crimped

Connection screen

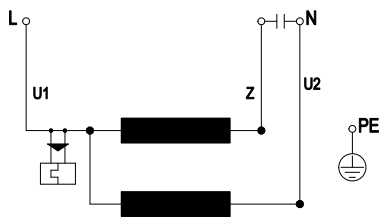

U1	blue	Z	brown	U2	black
PE	green/yellow				



AC centrifugal fan

forward curved, dual inlet
with housing (flange)

Charts: Air flow 50 Hz

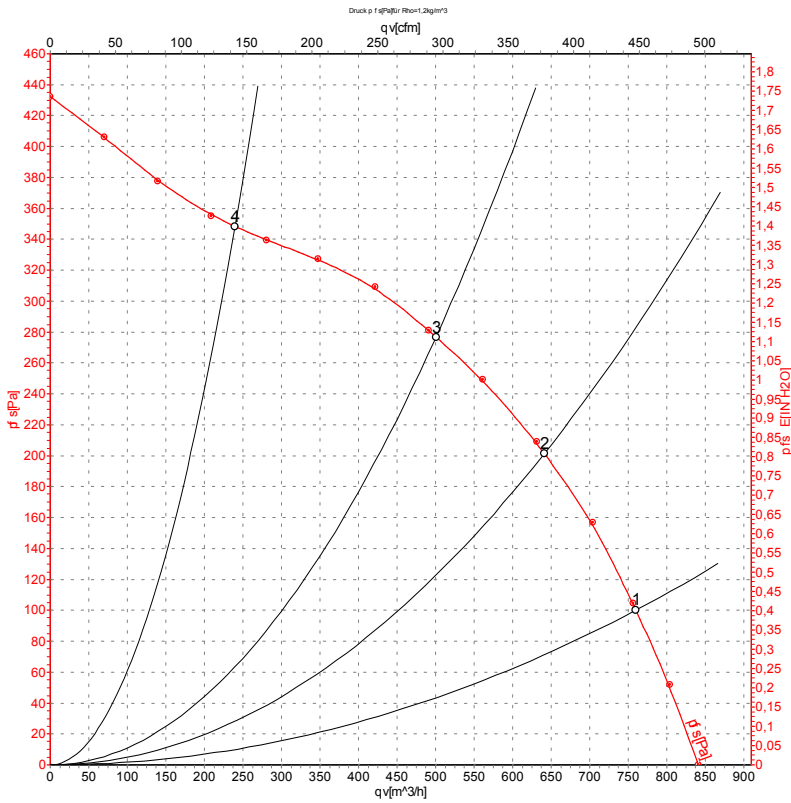

Measurement: LU-105266

Air performance measured as per ISO 5801 Installation category A. For detailed information on the measuring set-up, please contact ebm-papst. Suction-side noise levels: L_{wA} measured as per ISO 13347 / L_{pA} measured with 1m distance to fan axis. The values given are valid under the measuring conditions mentioned above and may vary according to the actual installation situation. With any deviation from the standard set-up, the specific values have to be checked and reviewed with the unit installed.

Measured values

	U	f	n	P _e	I	qv	p _{fs}
	V	Hz	min ⁻¹	W	A	m ³ /h	Pa
1	230	50	1650	175	0.78	760	100
2	230	50	1990	162	0.70	640	200
3	230	50	2275	146	0.63	500	275
4	230	50	2530	125	0.54	240	350

U = Supply voltage · f = Frequency · n = Speed · P_e = Power input · I = Current draw · qv = Air flow · p_{fs} = Pressure increase



AC centrifugal fan

forward curved, dual inlet

with housing (flange)

Charts: Air flow 60 Hz

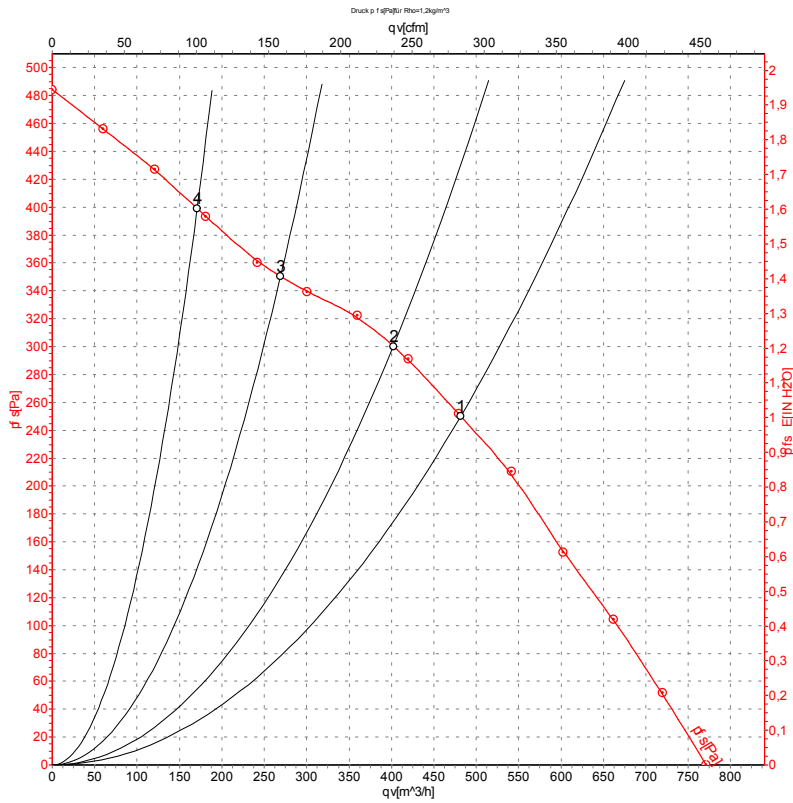

Measurement: LU-105267

Air performance measured as per ISO 5801 Installation category A. For detailed information on the measuring set-up, please contact ebm-papst. Suction-side noise levels: L_{wA} measured as per ISO 13347 / L_{pA} measured with 1m distance to fan axis. The values given are valid under the measuring conditions mentioned above and may vary according to the actual installation situation. With any deviation from the standard set-up, the specific values have to be checked and reviewed with the unit installed.

Measured values

	U	f	n	P _e	I	qv	P _{fs}
	V	Hz	min ⁻¹	W	A	m ³ /h	Pa
1	230	60	2200	185	0.82	480	250
2	230	60	2360	181	0.78	400	300
3	230	60	2555	175	0.76	270	350
4	230	60	2685	171	0.74	170	400

U = Supply voltage · f = Frequency · n = Speed · P_e = Power input · I = Current draw · qv = Air flow · P_{fs} = Pressure increase

