

A	B	C	D	E	F	G
ISS.	DATE	E.C.N.	DESCRIPTION			
2	15-Jan-07	1/07/1198	SCALLOP SIZE INCREASED			
2A	20-09-12	09/12/1348	TOLERANCE CHANGE			

© 2011 CTP-COIL
ALL DIMENSIONS IN mm

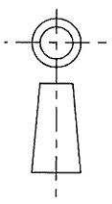

CUSTOMER DRAWING

carclo
technical plastics

CARCLO TECHNICAL PLASTICS (SLOUGH)
103 BUCKINGHAM AVE, SLOUGH
SL1 4PF, ENGLAND

TEL: +44 1753 610800 FAX: +44 1753 811359
e-mail: design@carclo-optics.com

GENERAL TOLERANCES (UNLESS STATED)

LINEAR	ANGULAR
X +/- 0.25	X +/- 1°
X.X +/- 0.1	X.X +/- 0.5°
X.XX +/- 0.05	X.XX +/- 0.1°

CUSTOMER

CARCLO

TITLE

LED Optic 25 Deg Linear
Orthogonal Variant

DRAWN

AJD

DATE 28-Jul-06

CHK'D

DATE

APP'D

DATE

SCALE

2:1

CARCLO PART No.

10192

SIZE

A4

CARCLO DRG. No.

60430

SHEET

2 OF 2

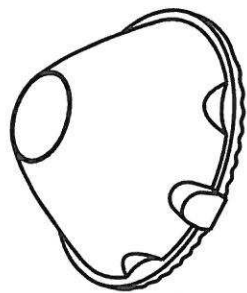
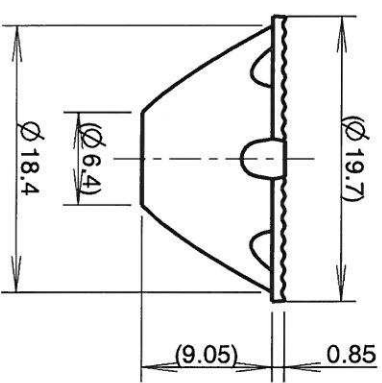
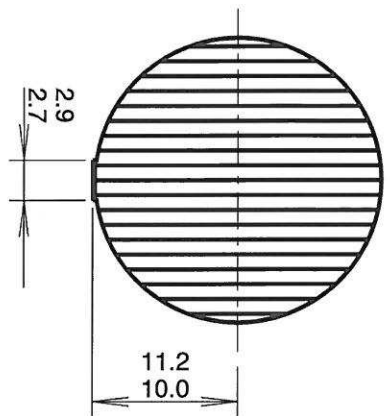

3D VIEW

NOTES:-
1. MATERIAL: UV STABILISED POLYCARBONATE