

ISS.	DATE	E.C.N.	DESCRIPTION
2	24-Jul-08		PIN DIA CHANGED FROM 9.0 TO 8.7 TIR SURFACE RE-OPTIMISED

© 2008 CARCLO
ALL DIMENSIONS IN mm

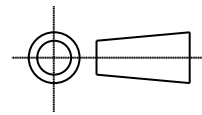

CARCLO TECHNICAL PLASTICS (SLOUGH) LTD.
111 BUCKINGHAM AVE, SLOUGH
SL1 4PF, ENGLAND
TEL: +44 1753 575011 FAX: +44 1753 811359
e-mail: design@ctcoil.co.uk}

CUSTOMER DRAWING

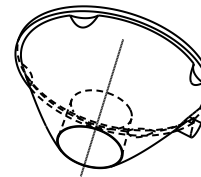
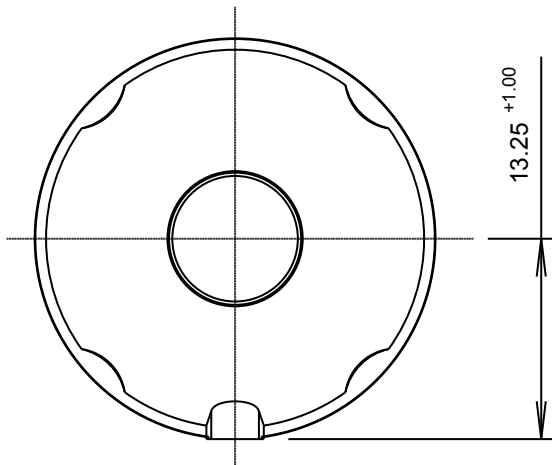

SCALE 1:1
GENERAL VIEW

GENERAL TOLERANCES (UNLESS STATED)

LINEAR	ANGULAR
X +/- 0.25	X +/- 1°
X.X +/- 0.1	X.X +/- 0.5°
X.XX +/- 0.05	X.XX +/- 0.1°

CUSTOMER

TITLE

26.5mm OPTIC 0.8mm OFFSET
MEDIUM FROSTED

DRAWN M.K. DATE 2-June-08

CHK'D DATE

APP'D DATE

SCALE
2:1

COIL PART No.
10393

SIZE
A4

COIL DRG. No.
60509

SHEET
1 OF 1

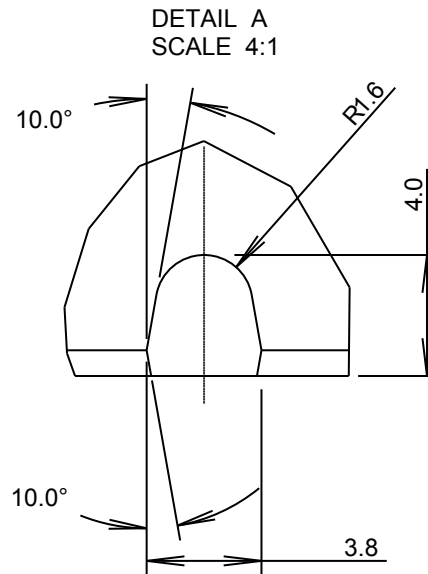
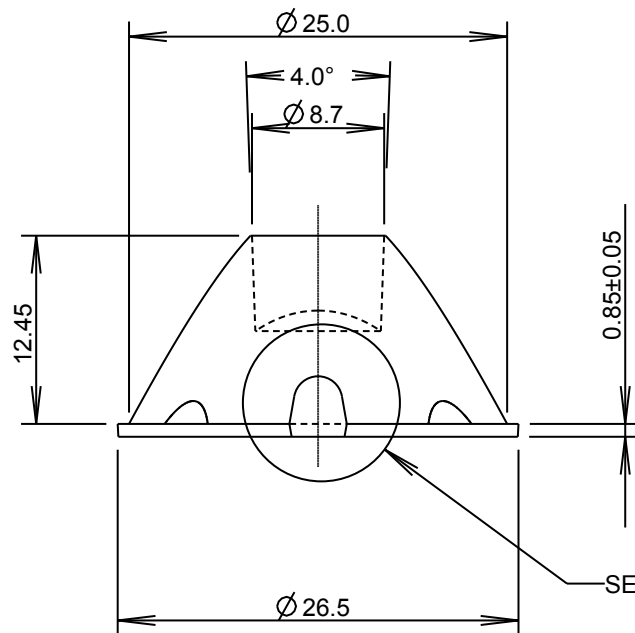

MATERIAL: POLYCARBONATE