

CUSTOMER DRAWING

©2011 CTP-COIL
ALL DIMENSIONS IN mm

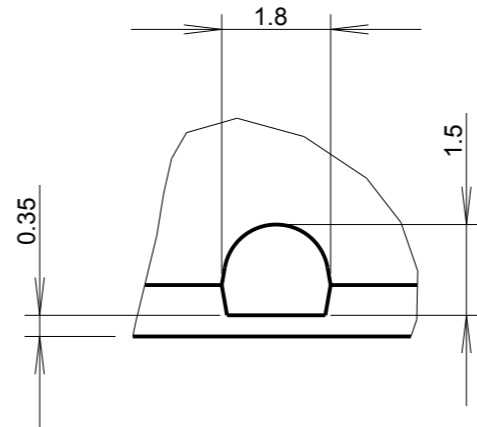

DETAIL B
SCALE 8:1

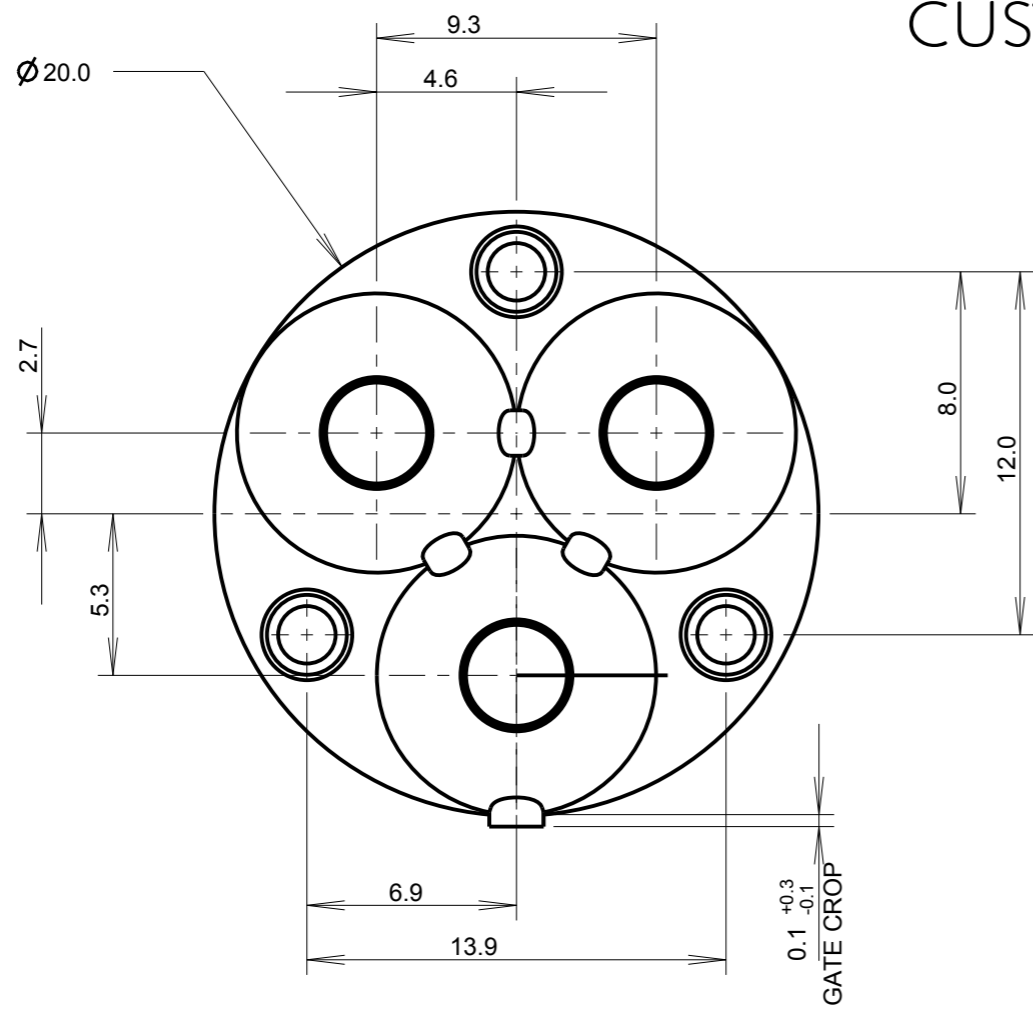
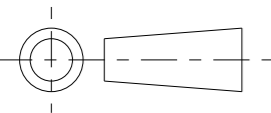
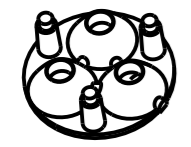
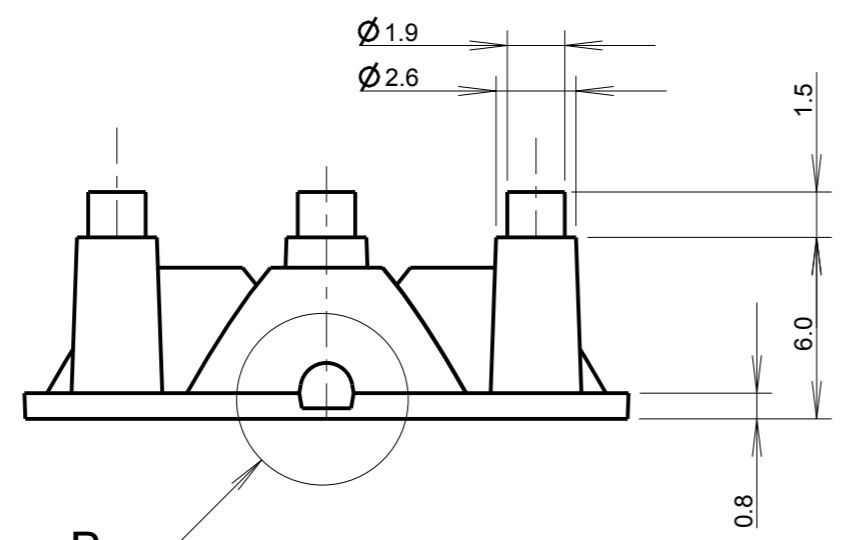

SCALE 1:1

MATERIAL - UV STABILISED CLEAR POLYCARBONATE

ISS.	DATE	E.C.N.	DESCRIPTION
1	06-May-08		FIRST ISSUE
2	18-Jun-08		GATE SIZE INCREASED
3	12-Nov-08	10/08/1233	LEG PIN LENGTH REDUCED TO 15MM
3A	10-Aug-11	08/11/1306	Gate tolerance updated



technical plastics
CARCLO TECHNICAL PLASTICS (SLOUGH)
 103 BUCKINGHAM AVE, SLOUGH
 SL1 4PF, ENGLAND
 TEL: +44 1753 575011 FAX: +44 1753 811359
 email: design@carclo-optics.com

GENERAL TOLERANCES (UNLESS STATED)

LINEAR	ANGULAR
X +/- 0.25	X +/- 1°
X.X +/- 0.1	X.X +/- 0.5°
X.XX +/- 0.05	X.XX +/- 0.1°

CUSTOMER
CARCLO

TITLE
**10mm TRIPLE OPTIC
 NARROW FROSTED**

DRAWN M.K. DATE 06-May-08

CHK'D PW DATE 10-Aug-11

APP'D BB DATE 10-Aug-11

SCALE 4:1 CARCLO PART No. 10511

SIZE A3 CARCLO DRG. No. 60528 SHEET 2 OF 3

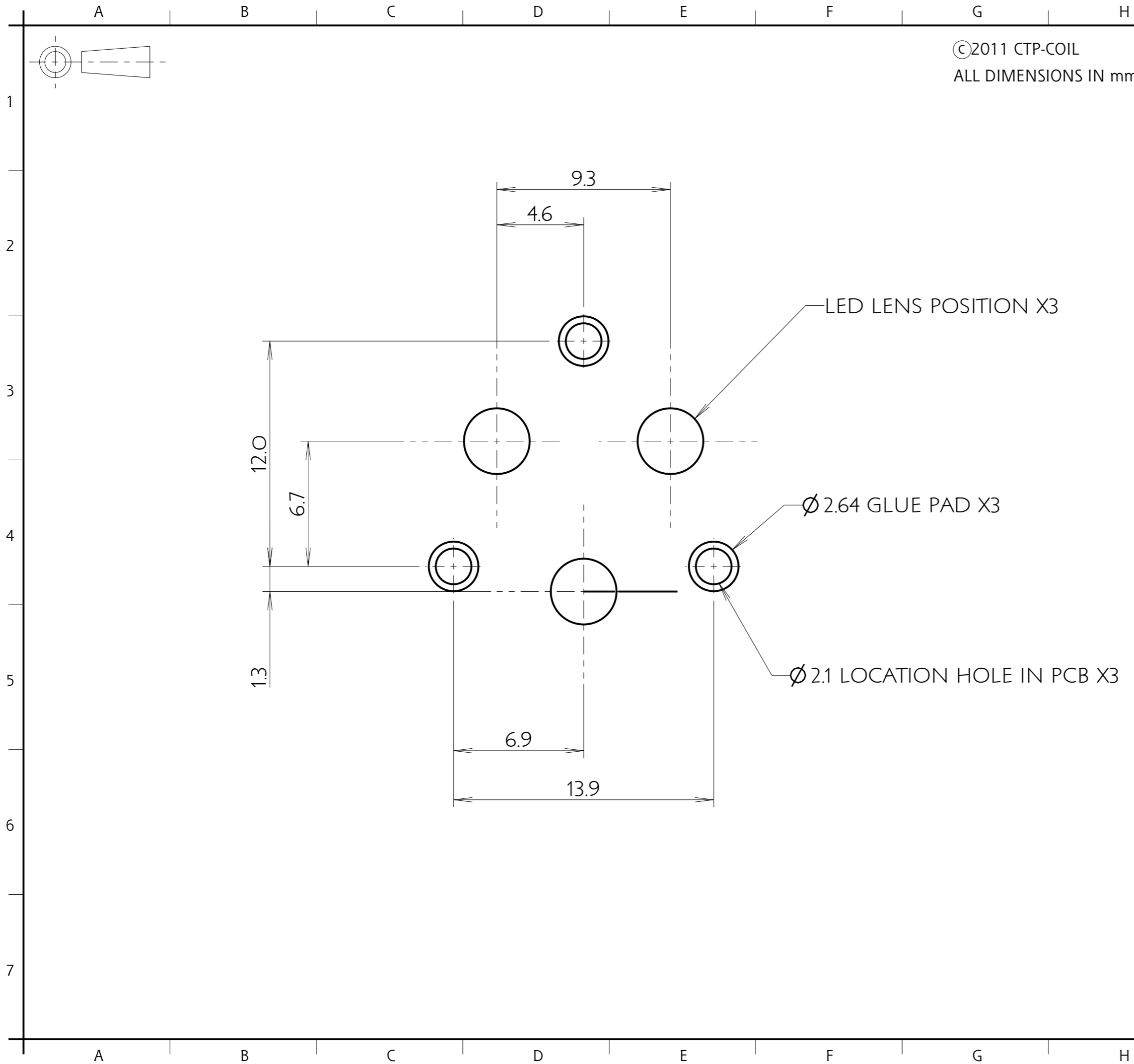

ISS.	DATE	E.C.N.	DESCRIPTION
1	06-May-08		FIRST ISSUE
2	18-Jun-08		GATE SIZE INCREASED
3	12-Nov-08	10/08/1233	LEG PIN LENGTH REDUCED TO 15MM
3A	10-Aug-11	08/11/1306	Gate tolerance updated

 technical plastics
CARCLO TECHNICAL PLASTICS (SLOUGH)
 103 BUCKINGHAM AVE, SLOUGH
 SL1 4PF, ENGLAND
 TEL: +44 1753 575011 FAX: +44 1753 811359
 email: design@carclo-optics.com

GENERAL TOLERANCES (UNLESS STATED)

LINEAR		ANGULAR	
X	+/- 0.25	X	+/- 1°
X.X	+/- 0.1	X.X	+/- 0.5°
X.XX	+/- 0.05	X.XX	+/- 0.1°

CUSTOMER	CARCLO
----------	--------

TITLE	10mm TRIPLE OPTIC NARROW FROSTED
-------	-------------------------------------

DRAWN	M.K.	DATE	06-May-08
-------	------	------	-----------

CHK'D	PW	DATE	10-Aug-11
-------	----	------	-----------

APP'D	BB	DATE	10-Aug-11
-------	----	------	-----------

SCALE	5:1	CARCLO PART No.	10511
-------	-----	-----------------	-------

SIZE	A3	CARCLO DRG. No.	60528	SHEET	3 OF 3
------	----	-----------------	-------	-------	--------