

CUSTOMER DRAWING

©2011 CTP-COIL
ALL DIMENSIONS IN mm

ISS.	DATE	E.C.N.	DESCRIPTION
1	18-Aug-10		FIRST ISSUE
2	23-Mar-11	03/11/1294	ADD RECESS & DIM
3	17-Nov-11	11/11/1314	CHANGE 2.0MM PEGS HEIGHT TO 0.8mm

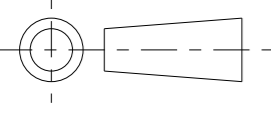

GENERAL VIEW



SCALE 1:1

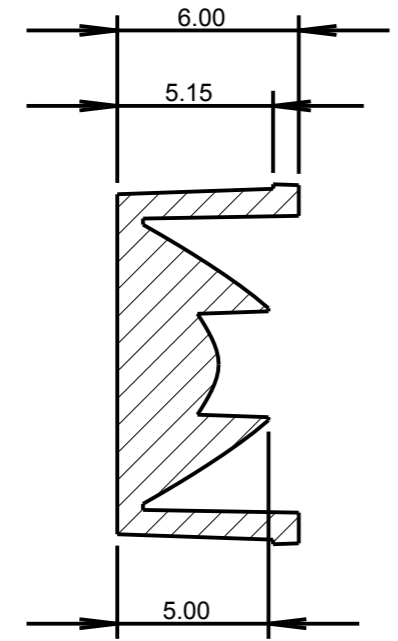

SECTION X-X

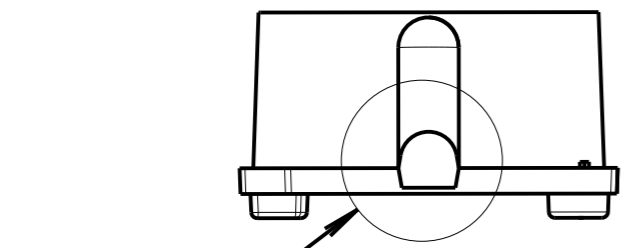
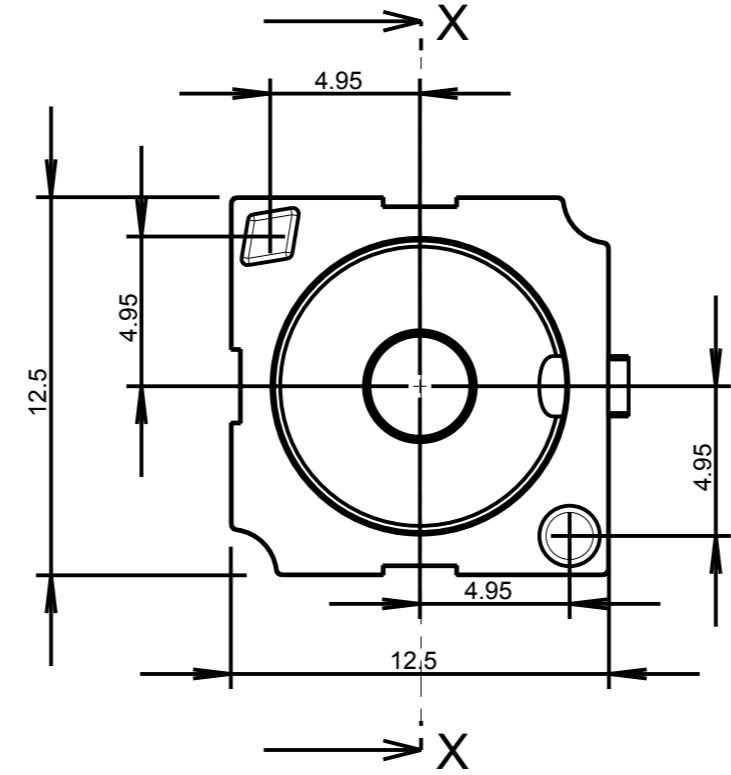

SEE DETAIL E

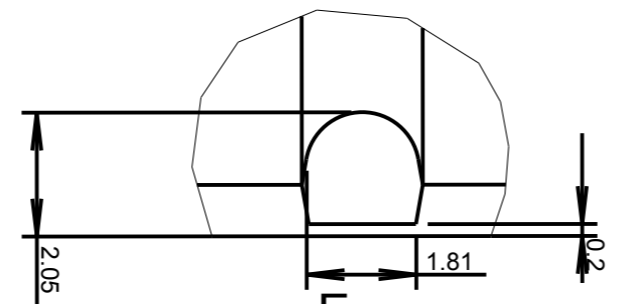

DETAIL E
SCALE 8:1

FROSTED FINISH	CARCLO PART No
NARROW FROSTED	10771
MEDIUM FROSTED	10772

MATERIAL - UV STABILISED CLEAR POLYCARBONATE



CARCLO TECHNICAL PLASTICS (SLOUGH)
103 BUCKINGHAM AVE, SLOUGH
SL1 4PF, ENGLAND
TEL: +44 1753 575011 FAX: +44 1753 811359
email: design@carclo-optics.com

GENERAL TOLERANCES (UNLESS STATED)

LINEAR	ANGULAR
X +/- 0.25	X +/- 1°
X.X +/- 0.1	X.X +/- 0.5°
X.XX +/- 0.05	X.XX +/- 0.1°

CUSTOMER
CARCLO

TITLE
10mm IP66 NARROW & MEDIUM FROSTED OPTICS

DRAWN BB DATE 18-Aug-10

CHK'D MH DATE 29-Nov-11

APP'D PW DATE 29-Nov-11

SCALE 4:1 CARCLO PART No. see table

SIZE A3 CARCLO DRG. No. 60596 SHEET 2 OF 3

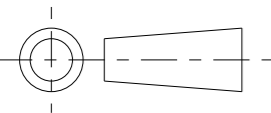

©2011 CTP-COIL
ALL DIMENSIONS IN mm

PCB GLUE PAD AND ALIGNMENT HOLE LAYOUT DIMENSIONS

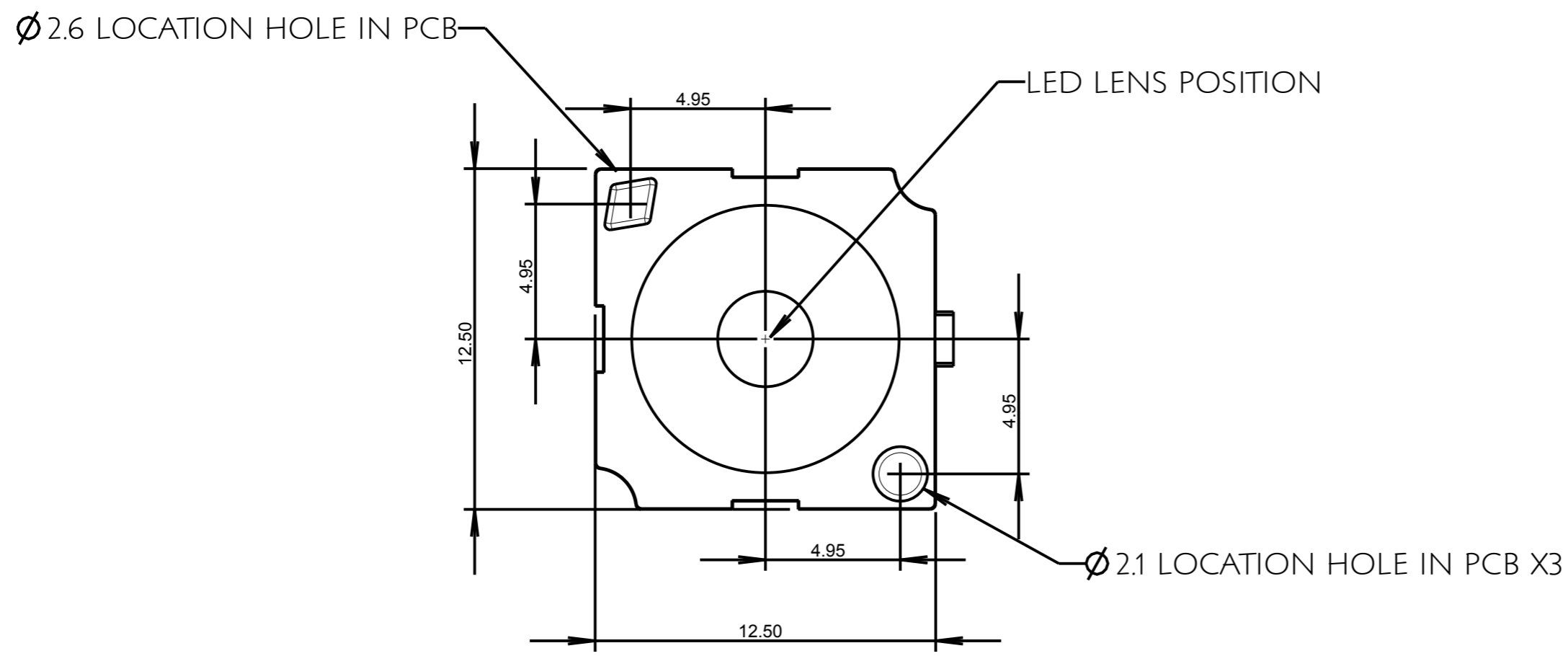

FROSTED FINISH	CARCLO PART No
NARROW FROSTED	10771
MEDIUM FROSTED	10772

ISS.	DATE	E.C.N.	DESCRIPTION
1	18-Aug-10		FIRST ISSUE
2	23-Mar-11	03/11/1294	ADD RECESS & DIM
3	17-Nov-11	11/11/1314	CHANGE 2.0MM PEGS HEIGHT TO 0.8mm

 technical plastics
CARCLO TECHNICAL PLASTICS (SLOUGH)
 103 BUCKINGHAM AVE, SLOUGH
 SL1 4PF, ENGLAND
 TEL: +44 1753 575011 FAX: +44 1753 811359
 email: design@carclo-optics.com

GENERAL TOLERANCES (UNLESS STATED)

LINEAR	ANGULAR
X +/- 0.25	X +/- 1°
X.X +/- 0.1	X.X +/- 0.5°
X.XX +/- 0.05	X.XX +/- 0.1°

CUSTOMER
CARCLO

TITLE
10mm IP66 NARROW & MEDIUM FROSTED OPTICS

DRAWN BB DATE 18-Aug-10

CHK'D MH DATE 29-Nov-11

APP'D PW DATE 29-Nov-11

SCALE 5:1 CARCLO PART No. see table

SIZE A3 CARCLO DRG. No. 60596 SHEET 3 OF 3