

Crystal Clock Oscillator

NZ2520S Series

Ultralow Power-Driven Type

Model name

NZ2520SF Overall frequency tolerance of $\pm 100 \times 10^{-6}$.

Application

- For Portable equipment (ex. Mobile Phone, Digital Media Player, PND, Notebook PC, etc)

Features

- Ultralow power-driven (0.8V min) crystal clock oscillator, ideal for mobile devices.
- Compact and light. Dimensions : 2.5 x 2.0 x 0.9 mm, weight : 0.02 g.
- This crystal clock oscillator can support low frequencies (from 1.0MHz) not easily achieved with crystal units of the same size.
- Taped units enable automatic mounting and IR Reflow (lead free) is possible.
- Lead-free.



Pb Free

RoHS Compliant
Directive 2011/65/EU

Absolute maximum rating
Supply voltage (V_{CC}) -0.5 to $+4.0$ V
Storage temperature range -55 to $+125$ °C

Specifications

Item		Model	NZ2520SF					
Output level			CMOS					
Nominal frequency range *1		(MHz)	$1.5 \leq F < 10$	$10 \leq F < 20$	$20 \leq F < 30$	$30 \leq F < 40$	$40 \leq F \leq 50$	
Operating temperature range *2		(°C)	-20 to +70					
Overall frequency tolerance		($\times 10^{-6}$)	± 100					
Current consumption max	During operation	+0.9 V, 25 °C	(mA)	1.5	2.0	2.5	3.0	3.5
		+1.2 V, 25 °C		2.0	2.5	3.5	4.0	5.0
+1.5 V, 25 °C		2.5		3.5	4.5	5.0	6.0	
	During standby	+0.9 V to +1.5 V, 25 °C	(μ A)	100				
$V_{OL} \text{ max}/V_{OH} \text{ min}$		(V)	$0.1 V_{CC}/0.9 V_{CC}$					
$T_r \text{ max}/T_f \text{ max}$		(ns)	5/5					
Symmetry min. to max.		(%)	45 to 55					
Load (C_L) max		(pF)	15					
Start-up time max		(ms)	4					
Standby function			Available (Three-state)					

*1: If you require a product with a frequency not given above, please contact us.

*2: If you require a product with an operating temperature range not given above, please contact us.

List of Codes for Placing an Order

List of Codes for Placing an Order (The purchase order number differs according to the difference in supply voltage.)		NSA3468A	NSA3477A	NSA3469A
Supply voltage (V_{CC})	(V)	+0.9 \pm 0.1	+1.2 \pm 0.1	+1.5 \pm 0.1

■ Dimensions

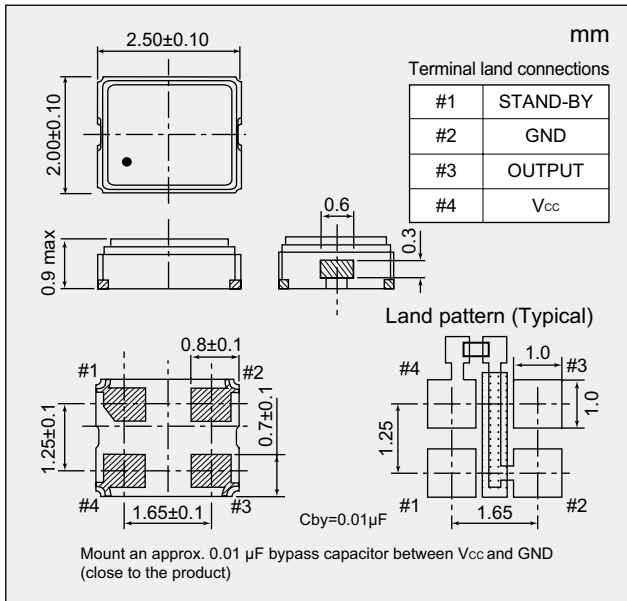

■ Output Waveform <CMOS>

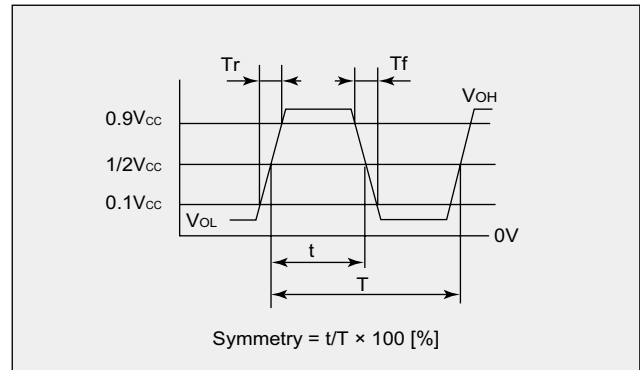

■ Standby Function

#1 Input	#3 Output
Level H ($0.7 V_{CC} \leq V_{IH} \leq V_{CC}$) or OPEN is selected.	Oscillation output ON
Level L ($V_{IL} \leq 0.3 V_{CC}$) is selected.	High impedance

■ How to Specify an Order

When ordering our products, specify them with an "Ordering Code" that consists of the following:

Model name – Frequency (up to 9 digits) M – Number for specifying an order

Example 1: When ordering a product with model name: NZ2520SF, frequency: 20 MHz, overall frequency tolerance: $\pm 100 \times 10^{-6}$, and power supply voltage: 0.9 V

Ordering Code: NZ2520SF – 20.000000M – NSA3468A

Example 2: When ordering a product with model name: NZ2520SF, frequency: 20 MHz, overall frequency tolerance: $\pm 100 \times 10^{-6}$, and power supply voltage: 1.5 V

Ordering Code: NZ2520SF – 20.000000M – NSA3469A

If you have any queries concerning our standard frequencies and numbers for specifying orders, please contact our sales representatives or visit our homepage (<http://www.ndk.com/>).