



AAVID
THERMALLOY

Advance Series (PA) 60mm x 60mm x 15mm



- » Bearing Type: FLB, Sleeve, Ball Bearing
- » Function Type (Optional): FG Signal
- » Protection (Optional) :
Auto Restart Protection
- » Lead Wire:
UL 1061 AWG #26 or Equivalent
Red Wire: Positive (+)
Black Wire: Negative (-)
Yellow Wire: FG Signal

PERFORMANCE CURVES

DIMENSIONS DRAWING

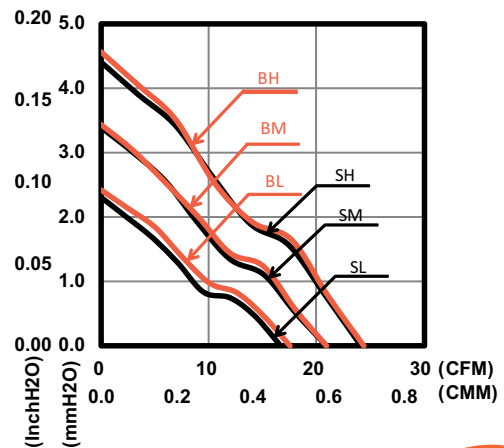
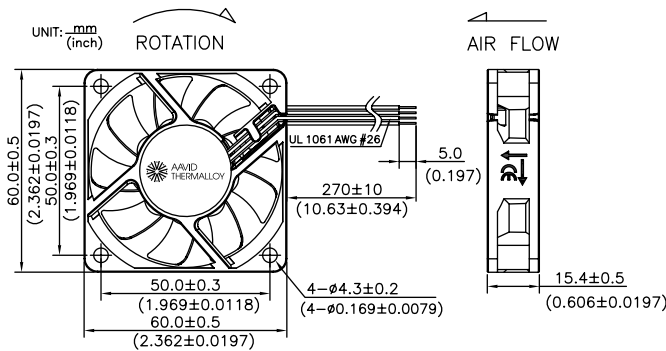

SPECIFICATION



Model	Function Type	Rated Voltage	Operating Voltage	Rated Current	Input Current	Input Power	Rated Speed	Air Flow		Air Pressure		Noise
		VDC	VDC	Amp	Amp	Watt		RPM	CMM	CFM	mmH2O	
PAAD06015SL	0000/F000 P000/PF00	5	4~5.75	0.55	0.16	0.80	3200	0.47	16.6	2.31	0.09	24.5
PAAD06015SM		5	4~5.75	0.70	0.22	1.10	3900	0.59	20.9	3.39	0.13	30.0
PAAD06015SH		5	4~5.75	0.85	0.35	1.75	4500	0.68	24.1	4.41	0.17	33.0
PAAD16015SL	0000/F000 P000/PF00	12	6~13.8	0.15	0.08	0.96	3200	0.47	16.6	2.31	0.09	24.5
PAAD16015SM		12	6~13.8	0.25	0.12	1.44	3900	0.59	20.9	3.39	0.13	30.0
PAAD16015SH		12	6~13.8	0.35	0.16	1.92	4500	0.68	24.1	4.41	0.17	33.0
PAAD26015SH	0000/F000 P000/PF00	24	12~27.6	0.20	0.09	2.16	4500	0.68	24.1	4.41	0.17	33.0
PAAD06015BL	0000/F000 P000/PF00	5	4~5.75	0.55	0.16	0.80	3300	0.50	17.5	2.42	0.10	24.5
PAAD06015BM		5	4~5.75	0.70	0.22	1.10	4000	0.59	20.9	3.43	0.14	30.5
PAAD06015BH		5	4~5.75	0.85	0.35	1.75	4600	0.69	24.4	4.56	0.18	34.5
PAAD16015BL	0000/F000 P000/PF00	12	6~13.8	0.15	0.08	0.96	3300	0.50	17.5	2.42	0.10	24.5
PAAD16015BM		12	6~13.8	0.25	0.12	1.44	4000	0.59	20.9	3.43	0.14	30.5
PAAD16015BH		12	6~13.8	0.35	0.16	1.92	4600	0.69	24.4	4.56	0.18	34.5
PAAD26015BH	0000/F000 P000/PF00	24	12~27.6	0.20	0.09	2.16	4600	0.69	24.4	4.56	0.18	34.5

* Specifications are subject to change without notice