

THIS INFORMATION IS CONFIDENTIAL AND PROPRIETARY TO CW INDUSTRIES INCORPORATED AND ITS AFFILIATES. IT MAY NOT BE DISCLOSED TO ANYONE OTHER THAN CW INDUSTRIES PERSONNEL, WITHOUT WRITTEN AUTHORIZATION FROM CW INDUSTRIES INCORPORATED, SOUTHAMPTON, PENNSYLVANIA USA.

E
D
C
B
A

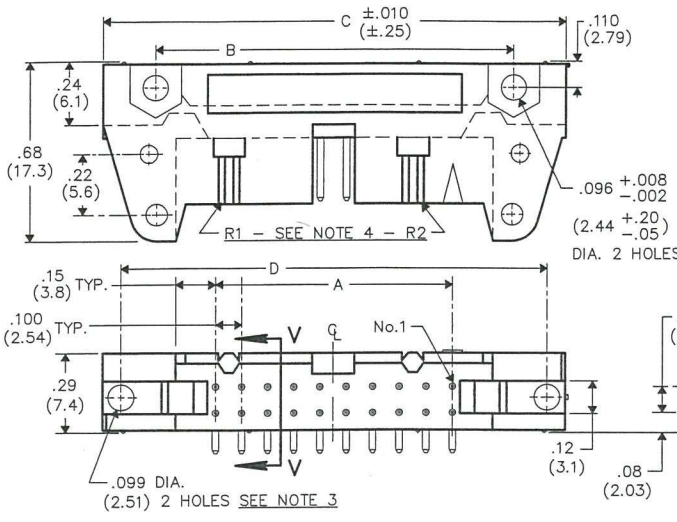

CWN-XXX-XX-XXXX

Type of Connector
 3= Polarized Header
 4= Non-Polarized

Pin Configuration
 0= Right Angle solder pins .090±.010 (2.29±.25) long, .025 (.64) Rnd.
 1= Right Angle solder pins .155±.010 (3.94±.25) long, .025 (.64) Rnd.
 2= Right Angle wire wrap pins .610±.010 (15.49±.25) long, .025 (.64) Sq.

Plating
 -0000 = 10μ in. gold (in mating area) over 50μ in. nickel
 -0021 = 30μ in. gold (in mating area) over 50μ in. nickel (Standard)

Number of Contacts
 (10, 14, 16, 20, 26, 34, 40, 50 & 60)

Latches (REF. OPTIONS)
 0 = No Latches
 ① = Short Latches for Non-Strain relief sockets
 E=.425 (10.80)/F= 1.02 (25.9)/G=.40 (10.2)
 ② = Long Latches for Strain relief sockets
 E=.573 (14.55)/F= 1.16 (29.5)/G=.51 (12.6)

DIMENSIONS IN INCHES (MILLIMETERS)
DO NOT SCALE DRAWING

Dwg. No. **CWN-3,4XX-XX-XXXX**

CONNECTOR DIMENSIONS				
XX NO. CONT's	A	B	C	D
10	.400 (10.16)	.860 (21.84)	1.260 (32.00)	1.100 (27.94)
14	.600 (15.24)	1.060 (26.92)	1.460 (37.08)	1.300 (33.02)
16	.700 (17.78)	1.160 (29.46)	1.560 (39.62)	1.400 (35.56)
20	.900 (22.86)	1.360 (34.54)	1.760 (44.70)	1.600 (40.64)
26	1.200 (30.48)	1.660 (42.16)	2.060 (52.32)	1.900 (48.26)
34	1.600 (40.64)	2.060 (52.32)	2.460 (62.48)	2.300 (58.42)
40	1.900 (48.26)	2.360 (59.94)	2.760 (70.10)	2.600 (66.04)
50	2.400 (60.96)	2.860 (72.64)	3.260 (82.80)	3.100 (78.74)
60	2.900 (73.66)	3.360 (85.34)	3.760 (95.50)	3.600 (91.44)

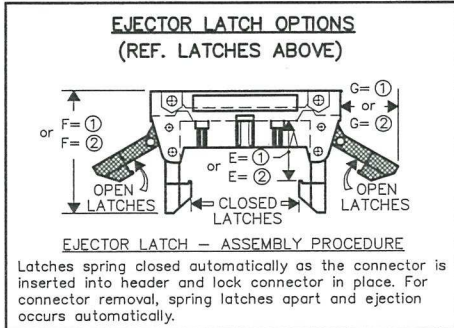
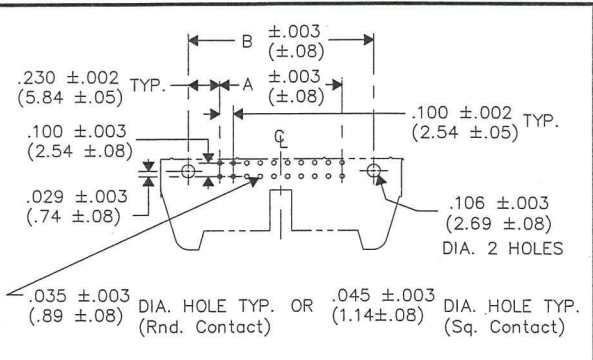

NOTES:

- 1) Dimensions are in inches; Dimensions in () are in millimeters.
- 2) Metric equivalents are given for general information only, and are based upon 1.00 inches equals (25.4) millimeters.
- 3) Holes centered ±.005 between adjacent flanges.
- 4) Part is made with removable ribs, drawing title indicates with or without, omit (R2) in size 10 and 14 headers.

MATERIALS:

PLASTIC PARTS- UL94V-0 Thermoplastic (blue,std.) flame retardant.
CONTACTS- Phosphor Bronze, standard (REF. PLATING ABOVE)

OPERATING STANDARDS:

TEMPERATURE RATING- -55°C to +125°C
CONTACT RATING- 1 AMPERE.
DIELECTRIC STRENGTH- OVER 500V.D.C. AT SEA LEVEL.
INSULATION RESISTANCE- GREATER THAN 5 x 10⁹ OHMS.

1 2 3 4 5 6 7 8 9 10

B-FORMAT 2002

REVISIONS

0
 RELEASED: 9-18-2012
 DWG: 1/10 JAN 11 2013

CUSTOMER DRAWING ONLY

PDF MADE	CW INDUSTRIES Southampton, Pa. 18966		Title: RIGHT ANGLE P.C.B. HEADER .100" x .100" CENTERS	
	TOLERANCES UNLESS OTHERWISE SPECIFIED			
	2 Place Decimal ±.010 METRIC		1 Place Dec. ±.25mm	
	3 Place Decimal ±.005		2 Place Dec. ±.13mm	
	Angles ±1'			
Made for: CW IND.			Division: CONNECTOR	
Drawn by: DGW 9-18-2012			Dwg. No.	
Checked by: <i>G. Guld</i> 1-11-13			CWN-3,4XX-XX-XXXX	
Approved: <i>C. Hammer</i> 1/11/13				

MASTER