

THIS INFORMATION IS CONFIDENTIAL AND PROPRIETARY TO CW INDUSTRIES INCORPORATED AND ITS AFFILIATES. IT MAY NOT BE DISCLOSED TO ANYONE, OTHER THAN CW INDUSTRIES PERSONNEL, WITHOUT WRITTEN AUTHORIZATION FROM CW INDUSTRIES INCORPORATED, SOUTHAMPTON, PENNSYLVANIA USA.

B-FORMAT 2002 REVISIONS 0
 RELEASED: 9-18-2012
 DWG: 9-11-2013
 CA / 11 JAN 11 2013

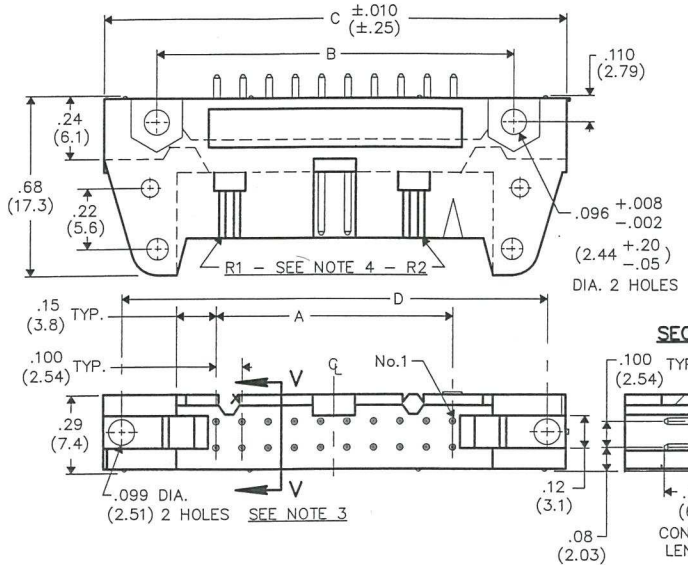

CWN-XXX-XX-XXXX

Type of Connector
 3= Polarized Header
 4= Non-Polarized

Pin Configuration
 5= Straight solder pins .090±.010 (2.29±.25) long, .025 (.64) Rnd.
 6= Straight solder pins .155±.010 (3.94±.25) long, .025 (.64) Rnd.
 7= Straight wire wrap pins .610±.010 (15.49±.25) long, .025 (.64) Sq.

Plating
 -0000 = 10µ in. gold (in mating area) over 50µ in. nickel
 -0021 = 30µ in. gold (in mating area) over 50µ in. nickel (Standard)

Number of Contacts
 (10, 14, 16, 20, 26, 34, 40, 50 & 60)

Latches (REF. OPTIONS)
 0 = No Latches
 ① = Short Latches for Non-Strain relief sockets
 E=.425 (10.80)/F= 1.02 (25.9)/G=.40 (10.2)
 ② = Long Latches for Strain relief sockets
 E=.573 (14.55)/F= 1.16 (29.5)/G=.51 (12.6)

DIMENSIONS IN INCHES (MILLIMETERS)
 DO NOT SCALE DRAWING

Dwg. No. **CWN-3,4XX-XX-XXXX**

CONNECTOR DIMENSIONS				
XX NO. CONT's	A	B	C	D
10	.400 (10.16)	.860 (21.84)	1.260 (32.00)	1.100 (27.94)
14	.600 (15.24)	1.060 (26.92)	1.460 (37.08)	1.300 (33.02)
16	.700 (17.78)	1.160 (29.46)	1.560 (39.62)	1.400 (35.56)
20	.900 (22.86)	1.360 (34.54)	1.760 (44.70)	1.600 (40.64)
26	1.200 (30.48)	1.660 (42.16)	2.060 (52.32)	1.900 (48.26)
34	1.600 (40.64)	2.060 (52.32)	2.460 (62.48)	2.300 (58.42)
40	1.900 (48.26)	2.360 (59.94)	2.760 (70.10)	2.600 (66.04)
50	2.400 (60.96)	2.860 (72.64)	3.260 (82.80)	3.100 (78.74)
60	2.900 (73.66)	3.360 (85.34)	3.760 (95.50)	3.600 (91.44)

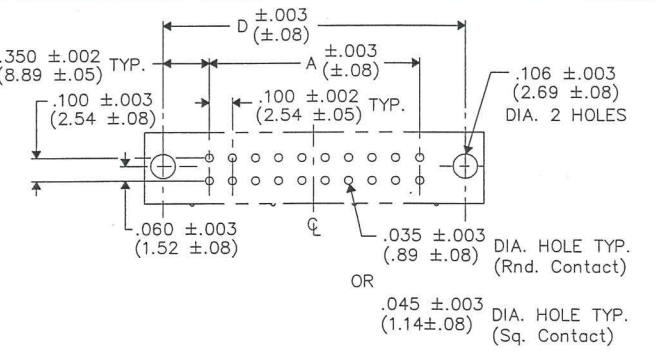

RECOMMENDED STRAIGHT P.C. BOARD LAYOUT

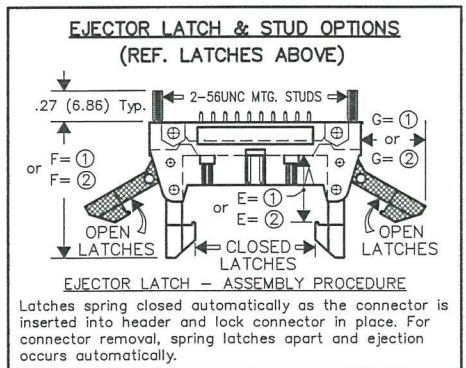

- NOTES:**
- 1) Dimensions are in inches; Dimensions in () are in millimeters.
 - 2) Metric equivalents are given for general information only, and are based upon 1.00 inches equals (25.4) millimeters.
 - 3) Holes centered ±.005 between adjacent flanges.
 - 4) Part is made with removable ribs, drawing title indicates with or without, omit (R2) in size 10 and 14 headers.

MATERIALS:
PLASTIC PARTS- UL94V-0 Thermoplastic (blue,std.) flame retardant.
CONTACTS- Phosphor Bronze, standard (REF. PLATING ABOVE)

OPERATING STANDARDS:
TEMPERATURE RATING- -55°C to +125°C
CONTACT RATING- 1 AMPERE.
DIELECTRIC STRENGTH- OVER 500V.D.C. AT SEA LEVEL.
INSULATION RESISTANCE- GREATER THAN 5 x 10⁹ OHMS.

CUSTOMER DRAWING ONLY

MASTER

1		2		3		4		5		6		7		8		9		10	
Southampton, Pa. 18966 TOLERANCES UNLESS OTHERWISE SPECIFIED 2 Place Decimal ±.010 METRIC 3 Place Decimal ±.005 1 Place Dec. ±.25mm Angles ±1' 2 Place Dec. ±.13mm Made for: CW IND. Drawn by: DGW 9-18-2012 Checked by: B. Guld 1-11-13 Approved: C. Howard 1/11/13																			
Title: STRAIGHT PIN P.C.B. HEADER .100" x .100" CENTERS																			
Division: CONNECTOR																			
Dwg. No. CWN-3,4XX-XX-XXXX																			