

DIMENSIONS IN INCHES (MILLIMETERS)
DO NOT SCALE DRAWING

Dwg. No.

CWR-280-XX-0203

NOTES:

1. Dimensions are in inches; dimensions in () are millimeters.
2. Metric equivalents are given for general information only, and are based upon 1.00 inches equals (25.4) millimeters.
3. Unless otherwise specified, tolerances are $\pm .005$ (.13) for three place decimals, and $\pm .01$ (.3) for two place decimals.

MATERIALS:

PLASTIC PARTS - UL94V-0 thermoplastic (blue, standard) flame retardant.

CONTACTS - Phosphor bronze.

CONTACT PLATING - .000100 (Min.) Tin Plating
All Over .000050 Min. Nickel

OPERATING STANDARDS:

TEMPERATURE RATING - 125° C

CONTACT RATING - 1 ampere.

DIELECTRIC STRENGTH - Over 500V.D.C. at sea level.

CONDUCTORS ACCEPTED - 28-30 AWG solid or stranded.

INSULATION RESISTANCE - Greater than 5×10^9 ohms.

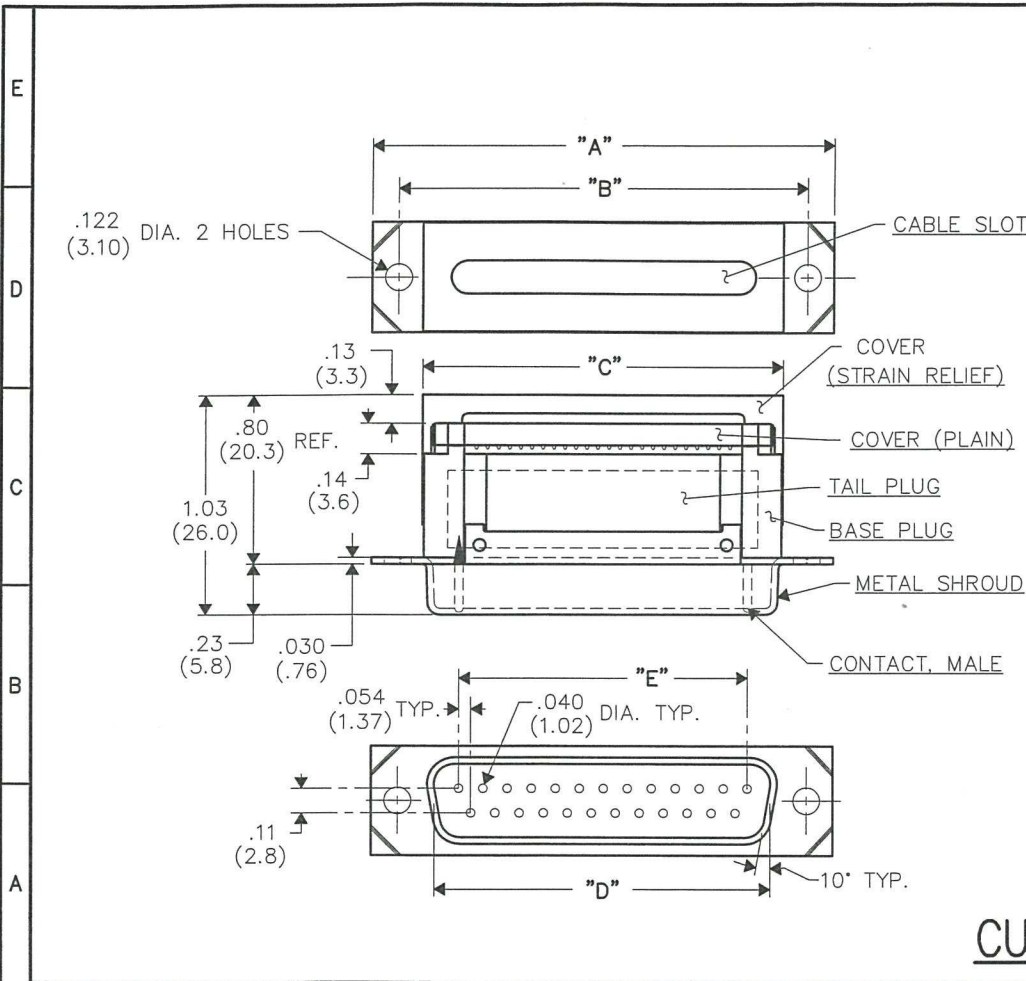

CUSTOMER DRAWING

NO. CONTS.	A	B	C	D	E
9	1.224 (31.09)	.984 (24.99)	.762 (19.35)	.656 (16.66)	.434 (11.02)
15	1.552 (39.42)	1.312 (33.32)	1.088 (27.64)	.982 (24.94)	.760 (19.30)
25	2.092 (53.14)	1.852 (47.04)	1.632 (41.45)	1.526 (38.76)	1.303 (33.10)
37	2.740 (69.60)	2.500 (63.50)	2.284 (58.01)	2.178 (55.32)	1.955 (49.66)

1 2 3 4 5 6 7 8 9 10

FORM-B4 REVISIONS RELEASED 9-18-2006 DGW SEP 20 2006	ATTENTION THIS DRAWING AND ITS ATTACHMENTS, IF ANY, ARE PROPRIETARY TO CW INDUSTRIES AND DESCRIBE DESIGNS THAT ARE CONFIDENTIAL AND MUST NOT BE DISCLOSED UNLESS AUTHORIZED, IN WRITING, BY AN OFFICER OF CW INDUSTRIES.....		CW INDUSTRIES Southampton, Pa. 18966 TOLERANCES UNLESS OTHERWISE SPECIFIED 2 Place Decimal $\pm .010$ METRIC 3 Place Decimal $\pm .005$ 1 Place Dec. $\pm .25$ mm Angles $\pm 1^\circ$ 2 Place Dec. $\pm .13$ mm	Title: METAL SHROUD "D" CONNECTER RECEPTACLE (MALE CONTACTS) Division: CONNECTER Dwg. No. CWR-280-XX-0203
	Made for: CW IND.	Drawn by: DGW 9-18-2006		
	Checked by: G. Gould 9-19-06	Approval: [Signature] 9-19-06		

MASTER