

THIS INFORMATION IS CONFIDENTIAL AND PROPRIETARY TO CW INDUSTRIES INCORPORATED AND ITS AFFILIATES. IT MAY NOT BE DISCLOSED TO ANYONE, OTHER THAN CW INDUSTRIES PERSONNEL, WITHOUT WRITTEN AUTHORIZATION FROM CW INDUSTRIES INCORPORATED, SOUTHAMPTON, PENNSYLVANIA USA.

Rating	16A 125VAC 1/3HP 10A 250VAC 1/2HP
	16(6)A 250VAC
	25A 14VDC , 15A 28VDC
Contact Resistance	50m ohm Max.
Insulation Resistance	DC 500V 100M ohm Min.
Dielectric Strength	AC 1500V 1 minute
Operation Temp.	- 25 ° C ~ 85 ° C
Switch Function	3P SPDT ON - OFF - ON

Mounting Hole			Circuit Diagram	
Thickness				
	0.75...2.5	27.6-0.1		13.8+0.1
	2.5...3.5	27.8-0.1		13.8+0.1
	3.5...4.5	28.0-0.1		13.8+0.1

*MATERIAL:
 Frame: Black, Nylon 66 (94-V2)
 Actuator: Black, PC (94-V2)
 Waterproof rubber: Black, Silicone
 Printed: None
 *Waterproof: IP65

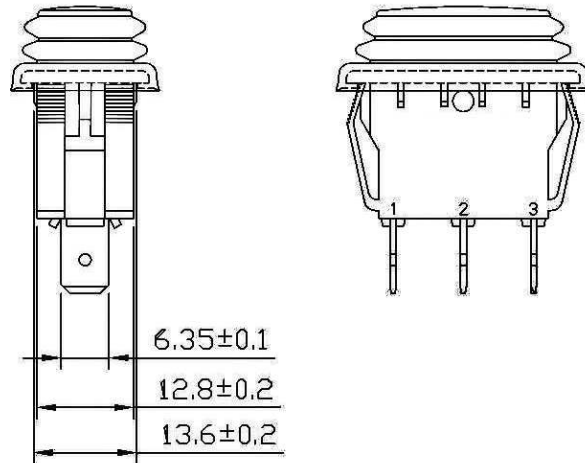
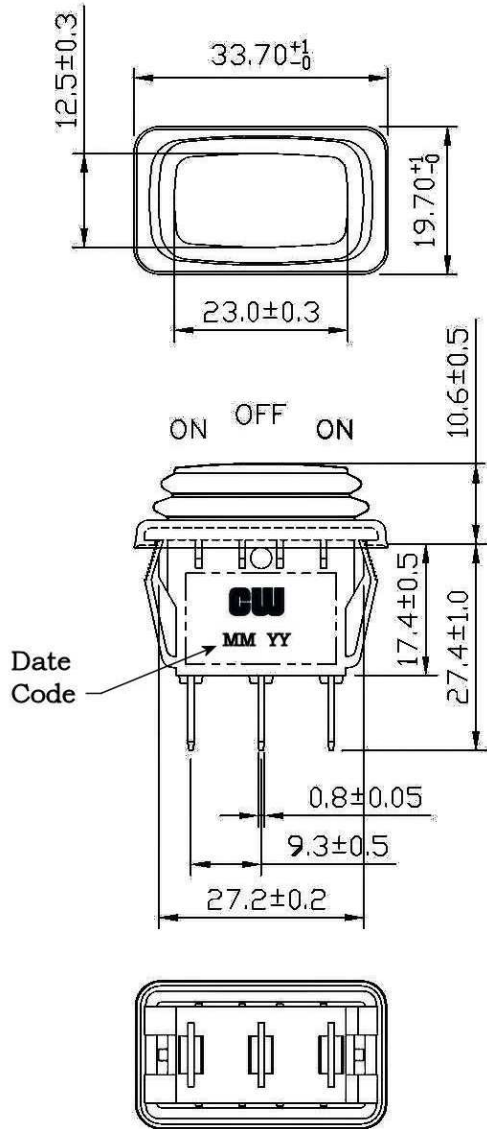

RoHS Compliant

1 Added date code to housing side. 1/17/11.

CW INDUSTRIES
 Southampton, Pa. 18966
 Tel 215.355.7080/www.cwind.com

Date Drawn: 7/02/10

Rev. 1

Unit: mm

Checked By: G.Guld

Title: **ROCKER SWITCH**

CW P/N: **GRB238D801BB**