



Switch Leg Transmitter (SLT)

- E3T-R02-2INTP (24 VAC)
- E3T-R12-2INTP (120 VAC)
- E3T-R24-2INTP (240 VAC)
- E3T-R27-2INTP (277 VAC)

The ILLUMRA™ Single Channel Switch Leg Transmitter (SLT) replaces wire between an electrical device and a control switch. The SLT senses status of photocell, timer, or manual switch master circuit to control wireless slave receiver(s).

Easy-To-Use

- Installs in minutes
- Easy-to-configure
- Eliminates need for switch-leg wires
- Communicates with ILLUMRA receivers

Reliable Range

- 50-150 foot range (typical)
- Unique ID of each SLT activates only the intended receiver(s)
- Repeaters available for added range

Save Time and Money

Run no switch leg wires when installing electrical loads. ILLUMRA Switch Leg Transmitters send wireless signals to receivers without costly and time-consuming wiring.

Save Energy

Conserve energy and save money by using the SLT in load shedding or energy-efficient HVAC control applications. Connect HVAC, lighting, or other devices to a Relay Receiver to turn them OFF and ON automatically in synch with any device connected to an SLT.

Threaded Nipple Relay

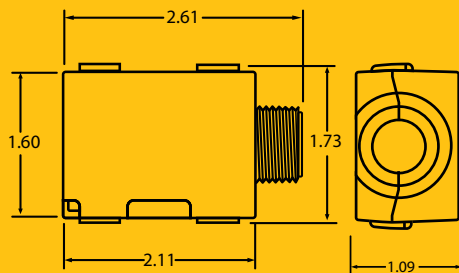

Simple Wireless Control

- Economy HVAC controls
- Interlocked motor controls
- Master / Slave lighting controls

Control The Way You Want It

- Wirelessly control new device(s) with an existing switch
- Sense status of photocell, timer, or manual switch master circuit to control wireless slave receiver(s)

	E3T-R02-2INTP	E3T-R12-2INTP	E3T-R24-2INTP	E3T-R27-2INTP
Range	50-150 feet (typical)			
Frequency	315 MHz			
Power Supply Input Rating	24 VAC 50/60 Hz	120 VAC 50/60 Hz	240 VAC 50/60 Hz	277 VAC 50/60 Hz
Operating Temperature	14° to +122°F (-10° to +50°C)			
Dimensions	2.11 x 1.73 x 1.09 inches (54 x 44 x 28 mm)			
Radio Certification	FCC (United States) SZV-TCM2XXC I.C. (Canada) 5713A-TCM2XXC			
Safety Approval	ETL (United States) UL244A ETL (Canada) CSAc22.2#14-05			
Addressing	Factory set unique ID (1 of 4 billion)			

Network Diagram

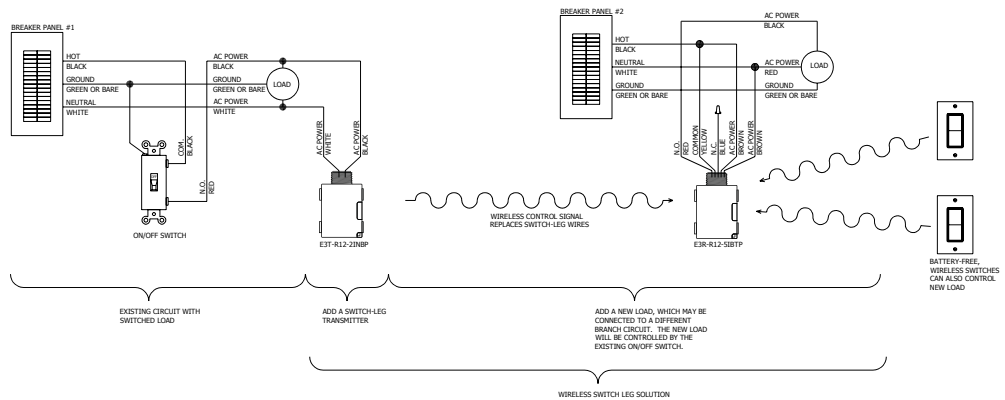

815 W. 1250 S. #118
Orem, UT 84058

T: (801) 349-1200
F: (801) 614-7100
Sales@ILLUMRA.com
Info@ILLUMRA.com
www.ILLUMRA.com

This device or certain aspects thereof is protected by at least one U.S. or international patent or has at least one such patent application pending.



AHD0206B

ILLUMRA is a trademark of Ad Hoc Electronics, I.L.C. Other trademarks herein are the property of their respective owners.

AHD0206A