

Notice for TAIYO YUDEN products

Please read this notice before using the TAIYO YUDEN products.

REMINDERS

- Product information in this catalog is as of October 2013. All of the contents specified herein are subject to change without notice due to technical improvements, etc. Therefore, please check for the latest information carefully before practical application or usage of the Products.

Please note that TAIYO YUDEN CO., LTD. shall not be responsible for any defects in products or equipment incorporating such products, which are caused under the conditions other than those specified in this catalog or individual specification.

- Please contact TAIYO YUDEN CO., LTD. for further details of product specifications as the individual specification is available.

- Please conduct validation and verification of products in actual condition of mounting and operating environment before commercial shipment of the equipment.

- All electronic components or functional modules listed in this catalog are developed, designed and intended for use in general electronics equipment.(for AV, office automation, household, office supply, information service, telecommunications, (such as mobile phone or PC) etc.). Before incorporating the components or devices into any equipment in the field such as transportation,(automotive control, train control, ship control), transportation signal, disaster prevention, medical, public information network (telephone exchange, base station) etc. which may have direct influence to harm or injure a human body, please contact TAIYO YUDEN CO., LTD. for more detail in advance.

Do not incorporate the products into any equipment in fields such as aerospace, aviation, nuclear control, submarine system, military, etc. where higher safety and reliability are especially required.

In addition, even electronic components or functional modules that are used for the general electronic equipment, if the equipment or the electric circuit require high safety or reliability function or performances, a sufficient reliability evaluation check for safety shall be performed before commercial shipment and moreover, due consideration to install a protective circuit is strongly recommended at customer's design stage.

- The contents of this catalog are applicable to the products which are purchased from our sales offices or distributors (so called "TAIYO YUDEN' s official sales channel").

It is only applicable to the products purchased from any of TAIYO YUDEN' s official sales channel.

- Please note that TAIYO YUDEN CO., LTD. shall have no responsibility for any controversies or disputes that may occur in connection with a third party's intellectual property rights and other related rights arising from your usage of products in this catalog. TAIYO YUDEN CO., LTD. grants no license for such rights.

- Caution for export

Certain items in this catalog may require specific procedures for export according to "Foreign Exchange and Foreign Trade Control Law" of Japan, "U.S. Export Administration Regulations", and other applicable regulations. Should you have any question or inquiry on this matter, please contact our sales staff.

COIN TYPE POLYACENE CAPACITORS



REFLOW

FEATURES

- High capacity / High reliability**
 Polyacene Capacitors can store a large number of ions into its amorphous structure (doping), therefore Polyacene Capacitors has much larger capacity than conventional electric double layer capacitor. In addition, Polyacene Capacitors is extremely stable material and Polyacene Capacitors shows excellent performance of cycle life and durability to overcharge and overdischarge.
- RoHS / WEEE compliance**
 Polyacene Capacitors are RoHS and WEEE compliant products and have no recycling and collection duty that is required in lithium ion battery's case.

APPLICATIONS

- Memory and RTC back-up power source used for cellular phone, PDA, digital camera, portable radio and so on.

ORDERING CODE

P A S 3 1 1 H R - V A 6 R

1 Series name	2 Diameter ϕD (mm)	3 Height H (mm)	4 Maximum Usable Voltage (V) / mounting	5 Common sign	6 Terminal Shape
PAS Polyacene Capacitors	3 3.8 4 4.8 6 6.8	11 1.1 14 1.4	HR 3.3 Reflow Soldering SR 2.6 Reflow Soldering L 3.3 Not Rflow Soldering	- Fixation	VA5R Individually specified VA6R Individually specified VE5R Individually specified VL3 Individually specified

EXTERNAL DIMENSIONS, WEIGHT



Type	ϕD (mm)	H (mm)	Weight (g)
311	3.8 (0.150)	1.1 (0.043)	0.03
414	4.8 (0.189)	1.4 (0.055)	0.06
614	6.8 (0.268)	1.4 (0.055)	0.15

※mm (inch), g

EXTERNAL DIMENSIONS

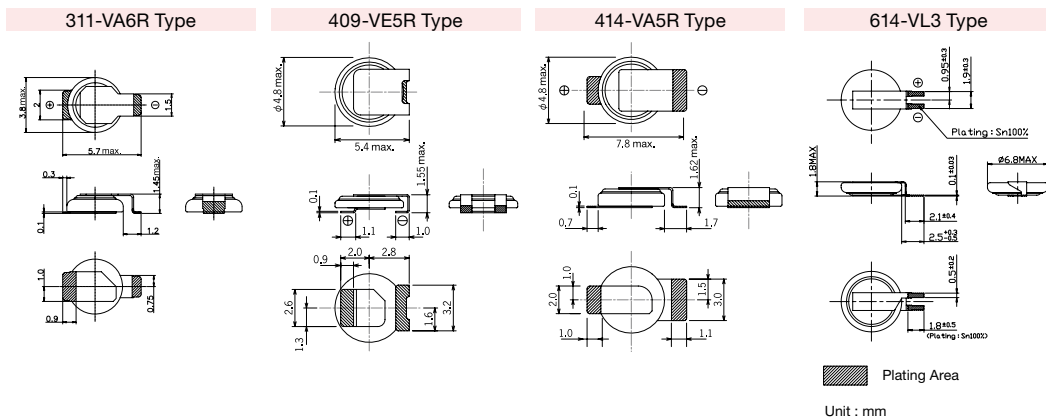

PART NUMBERS

Part Number	Terminal Shape	LeadFree Reflowable	RoHS	Maximum Usable Voltage (V)	Nominal Capacity (μAh)	Nominal Capacitance (F)	Typical Internal Resistance (Ω)
PAS311HR	VA6R	○	○	3.3	10 ⁻¹	0.03	120
PAS414HR	VA5R	○	○	3.3	22 ⁻¹	0.07	80
	VE5R	○	○				
PAS311SR	VA6R	○	○	2.6	11 ⁻²	0.035	70
PAS614L	VL3	×	○	3.3	90 ⁻¹	0.25	80

(*1) : Capacity is measured from maximum usable voltage to 2.0V.

(*2) : Capacity is measured from maximum usable voltage to 1.4V.

▶ This catalog contains the typical specification only due to the limitation of space. When you consider the purchase of our products, please check our specification. For details of each product (characteristics graph, reliability information, precautions for use, and so on), see our Web site (<http://www.ty-top.com/>).

HR Type

FEATURES

- Reflowable with lead-free condition
(Refer to Reliability Data for recommendable reflow pattern)
- Voltage can be set up freely below 3.3V

SPECIFICATIONS

Part Number	311HR	414HR
1. Operating Temp. Range	-20~+60°C	
2. Max. Usable Voltage	3.3V	
3. Initial Capacitance (F)	Over 0.02	Over 0.03
4. Initial Capacity (μ Ah)	Over 6	Over 10
5. Initial Internal Resistance (Ω)	Under 500	Under 250
6. Max. Discharge Current (μ A)	10	20
7. Temperature Characteristics	Highest temperature (60°C) Capacity : Over 90% of initial spec. Lowest temperature (-20°C) Capacity : Over 50% of initial spec.	

SR Type

FEATURES

- Reflowable with lead-free condition
(Refer to Reliability Data for recommendable reflow pattern)
- Voltage can be set up freely 2.6V

SPECIFICATIONS

Part Number	311SR
1. Operating Temp. Range	-25~+70°C
2. Max. Usable Voltage	2.6V
3. Initial Capacitance (F)	Over 0.025
4. Initial Capacity (μ Ah)	Over 8
5. Initial Internal Resistance (Ω)	Under 120
6. Max. Discharge Current (μ A)	10
7. Temperature Characteristics	Highest temperature (70°C) Capacitance : Over 90% of initial spec. Lowest temperature (-25°C) Capacitance : Over 50% of initial spec.

L Type

FEATURES

- Voltage can be set up freely from 1.5V to 3.3V
- Excellent self-discharging characteristics

SPECIFICATIONS

Part Number	L
1. Operating Temp. Range	-20~+60°C
2. Usable Voltage	1.5~3.3V
3. Initial Capacitance (F)	Over 0.14
4. Initial Capacity (μ Ah)	Over 50
5. Initial Internal Resistance (Ω)	Under 300
6. Max. Discharge Current (μ A)	50
7. Temperature Characteristics	Highest temperature (60°C) Capacity : Within initial spec. Lowest temperature (-20°C) Capacity : Over 50% of initial spec.

RELIABILITY DATA

Items	Specifications			Test Conditions, Remark
	HR type	SR type	L type	
1. Operating Temperature range	-20~+60°C	-25~+70°C	-20°C~+60°C	
2. Max. Usable Voltage	3.3V	2.6V	3.3V	
3. Resistance to Reflow Soldering Heat	Capacity/Capacitance: Within initial spec. Appearance : No noticeable abnormality			Conduct reflow soldering twice according to the reflow soldering test condition mentioned below. (Conduct the reflow in the condition of the voltage of 0.3V or lower.)
4. Soldering Heat Resistance	Capacity/Capacitance: Within initial spec. Appearance: No noticeable abnormality			Apply a soldering iron with temperature of 380°C±10°C for 3 seconds at the solder plating part of the terminal.
5. Floating Charge Characteristics	Capacity/Capacitance: Over 70% of initial spec. Appearance : No noticeable abnormality			Apply a max usage voltage to the capacitor for 500 hours at max. operating temp. and measure the floating charge characteristics after returning to normal temperature and humidity.
6. Charge/Discharge Cycle Characteristics	Capacity/Capacitance: Over 50% of initial spec. Appearance : No noticeable abnormality			Measure the charge/discharge cycle characteristics after the 10000 cycles of charge/discharge at 25±5°C with the charge/discharge cycle test condition for each part.
7. Thermal Durability	Capacity/Capacitance: Over 80% of initial spec. Appearance : No noticeable abnormality			Leave the capacitor in an atmosphere of 85°C±2°C and -30±2°C consecutively for 96 hours each, and return to normal temperature and humidity.
8. Humidity Durability	Capacity/Capacitance: Over 80% of initial spec. Appearance : No noticeable abnormality			Temperature : 40±2 °C, Humidity : 90~95%RH Leave the capacitor for under the condition for 96hours then return to normal temperature and humidity.
9. Vibration Durability	No exterior abnormality observed: initial spec. values retained			Apply a sine wave vibration of 1.5mm amplitude at frequency 10-55Hz, for 2hours per each direction (X,Y and Z), for 6 hours in total.

Reflow Soldering Test Condition

Reflow profile with lead free condition

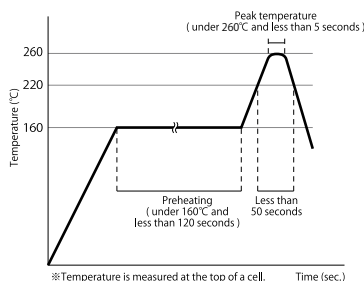

Cautions : Do not charge prior to reflow,
Set reflow condition within the range provided in "Specifications", which will be published separately.

Charge/Discharge Cycle Test Condition

Part Number	311HR	414HR	311SR	614L
Charging/Discharging Resistance (Ω)	3000	3000	150	1000
Charging Voltage (V)	3.3	3.3	2.5	3.3
Charging Time (min.)	12	24	5	24
Discharging Time (min.)	3	6	0.5	6

▶ This catalog contains the typical specification only due to the limitation of space. When you consider the purchase of our products, please check our specification. For details of each product (characteristics graph, reliability information, precautions for use, and so on), see our Web site (<http://www.ty-top.com/>).

COIN TYPE PAS CAPACITOR

PACKAGING

① Summary of Packaging Specifications

Item	Terminal Shape	Quantity per Reel	Products Direction (*)	Tape Width	Pitch	Reel Diameter	Emboss Shape
PAS311□□	VA6R	4000	—	16.0±0.3	8.0±0.1	330	A
PAS414□□	VA5R	4000	—	16.0±0.3	8.0±0.1	330	C
	VE5R	4000	—	16.0±0.3	8.0±0.1	330	C

Unit: mm

(*) Indicate the polarity of terminal which is close to sprocket hole.

② Taping Dimensions

● Emboss Shape A

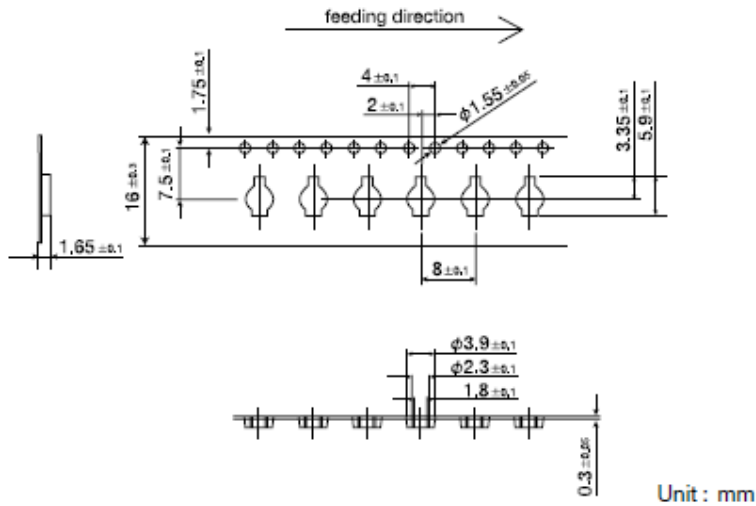

● Emboss Shape B

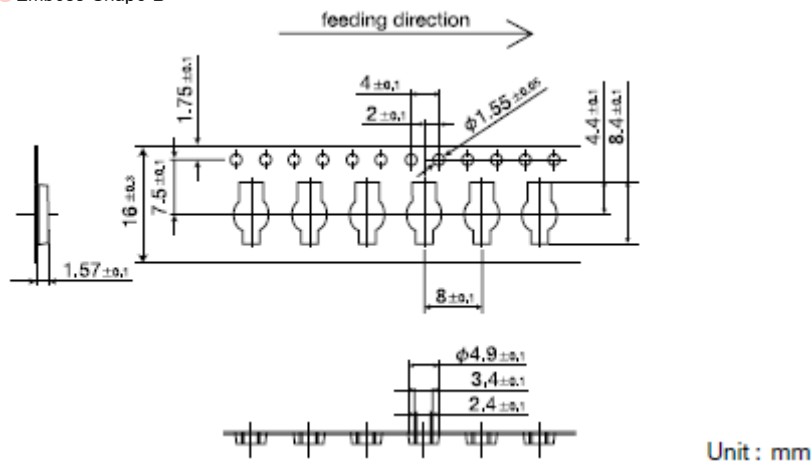

● Emboss Shape C

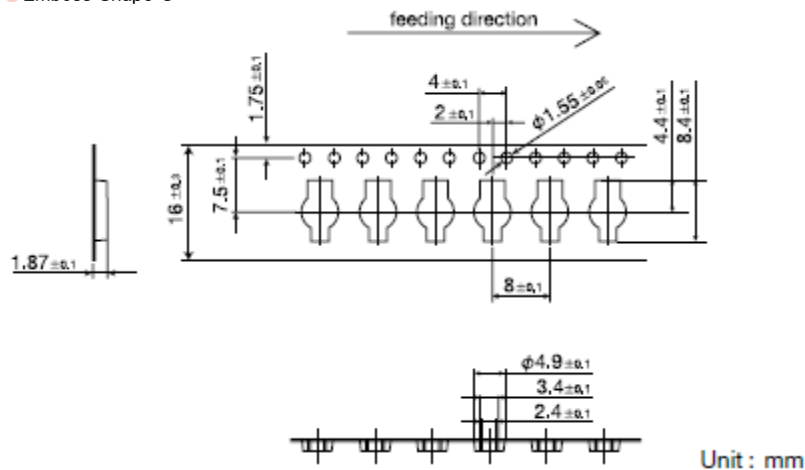

▶ This catalog contains the typical specification only due to the limitation of space. When you consider the purchase of our products, please check our specification. For details of each product (characteristics graph, reliability information, precautions for use, and so on), see our Web site (<http://www.ty-top.com/>).

③ Leader Section/Trailer Section

Leader section :Over 400mm(Containing at least 44 vacant pockets of carrier tape sealed with top cover tape)

Trailer section :Over 40mm(Over 5 vacant pockets of carrier tape sealed with top cover tape)

④ Reel Size

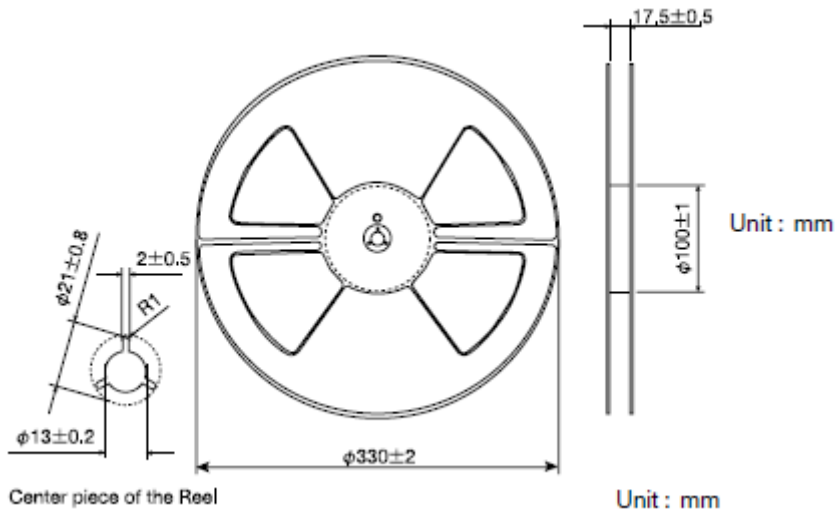

⑤ Peel Strength

0.1~0.7N under the condition of the figure below.

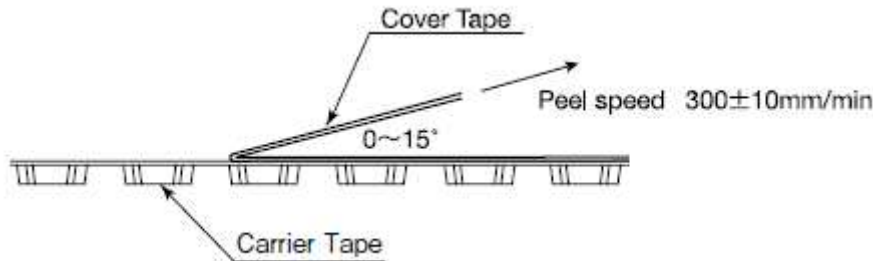

COIN TYPE PAS CAPACITOR

RELIABILITY DATA

1. Operating Temperature range

Specified Value	HR type	-20 ~ +60°C
	SR type	-25 ~ +70°C

2. Max. Usable Voltage

Specified Value	HR type	3.3V
	SR type	2.5V 2.6V (311SR)

3. Resistance to Reflow Soldering Heat

Specified Value	HR TYPE	Capacity/Capacitance	: Within initial spec.
	SR TYPE	Appearance	: No noticeable abnormality

Test Methods and Remarks
Conduct reflow soldering twice according to the reflow soldering test condition mentioned below.
(Conduct the reflow in the condition of the voltage of 0.3V or lower.)

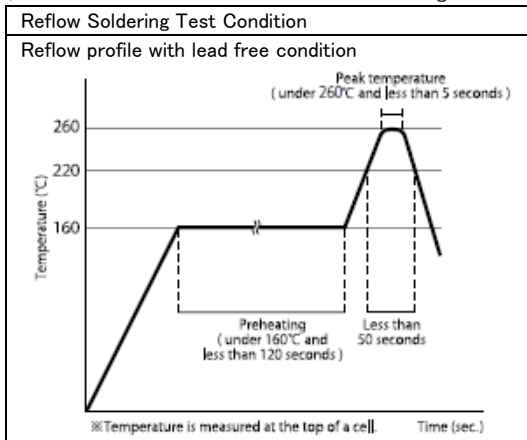

Cautions : Do not charge prior to reflow, Set reflow condition within the range provided in "Specifications", which will be published separately.

4. Floating Charge Characteristics

Specified Value	HR TYPE	Capacity/Capacitance	: Over 70% of initial spec.
	SR TYPE	Appearance	: No noticeable abnormality

Test Methods and Remarks
Apply a max.usage voltage to the capacitor for 500 hours at max. operating temp. and measure the floating charge characteristics after returning to normal temperature and humidity.

5. Charge/Discharge Cycle Characteristics

Specified Value	HR TYPE	Capacity/Capacitance	: Over 50% of initial spec.
	SR TYPE	Appearance	: No noticeable abnormality

Test Methods and Remarks
Measure the charge/discharge cycle characteristics after the 10000 cycles of charge/discharge at 25±5 °C with the charge/discharge cycle test condition for each part.

Charge/Discharge Cycle Test Condition

Part Number	311HR	414HR	311SR	414SR
Charging/Discharging Resistance (Ω)	3000	3000	150	150
Charging Voltage (V)	3.3	3.3	2.5	2.5
Charging Time (min.)	12	24	5	9
Discharging Time (min.)	3	6	0.5	1

6. Thermal Durability			
Specified Value	HR TYPE	Capacity/Capacitance Appearance	Over 80% of initial spec. No noticeable abnormality
	SR TYPE		
Test Methods and Remarks	Leave the capacitor in an atmosphere of $85^{\circ}\text{C} \pm 2^{\circ}\text{C}$ and $-30 \pm 2^{\circ}\text{C}$ consecutively for 96 hours each, and return to normal temperature and humidity.		
7. Humidity Durability			
Specified Value	HR TYPE	Capacity/Capacitance Appearance	Over 80% of initial spec. No noticeable abnormality
	SR TYPE		
Test Methods and Remarks	Temperature : $40 \pm 2^{\circ}\text{C}$, Humidity : 90~95%RH Leave the capacitor for under the condition for 96hours then return to normal temperature and humidity.		
8. Vibration Durability			
Specified Value	HR TYPE		No exterior abnormality observed : initial spec. values retained
	SR TYPE		
Test Methods and Remarks	Apply a sine wave vibration of 1.5mm amplitude at frequency 10~55Hz, for 2hours per each direction (X,Y and Z) , for 6 hours in total.		

COIN TYPE PAS CAPACITOR

■ PRECAUTIONS

1. Use under the maximum usable voltage.
If over maximum usable voltage is applied, it might cause abnormal current flow, which shorten lifetime, leakage and sometimes damage PAS capacitor.
2. Use under maximum operating temperature.
Not only shorter life time but also leakage and damage will happen by increasing internal pressure if PAS capacitor use in over max operating temperature.
3. Limited life time.
Lifetime of PAS capacitor is greatly affected by surrounding temperature. 10°C drop in temperature extend its expected lifetime approximately twice as much.
Design a circuit under consideration of deterioration of electrical characteristics after long time usage, decreasing in capacitance and increasing in internal resistance.
4. The electrical characteristics of capacitors vary with respect to temperature.
The electrical characteristics of PAS capacitors temporarily vary with respect to temperature separately from secular change mentioned above. Design a circuit under consideration of temperature characteristics.
5. PAS capacitor has polarity.
PAS capacitor has polarity. Please check the polarity before use. It will be damage if it is reverse charged.
6. Mind high ripple current or rapid charge / discharge.
In circuit with high ripple current or rapid charge / discharge, the lifetime of PAS capacitors might be shortened by self-heating.
7. Mind voltage drop when back-up.
When back-up (discharging) starts, voltage drop because of active current and internal resistance.
8. Series connection.
In case of using PAS capacitor in series connection, the voltage of each capacitor is not always equal and it may be occurred excessive voltage in a part of capacitor, which may lead to shortening lifetime and breakdown. Take a margin against a rated voltage or add a balancing resistor.
9. Don't contact with wiring pattern during installing
If PAS capacitor contact with wiring pattern, it will be short circuit, and if there is wiring pattern underneath of PAS capacitor, short circuit would occur by damage of resist.
10. Environmental of usage.
In case PAS capacitor is used in high humidity, alkaline or acid air, it may cause deteriorating of its performance and short circuit by corrosion of outer can or lead terminal. In addition, used in sudden temperature change or high humidity, it may cause deteriorating of its performance and electrolyte leak by dew condensation.
11. Don't apply shock and vibration or pressure.
PAS capacitor is sensitive to shock. Don't drop PAS capacitor and not apply strong pressure to a body, terminals and lead. Soldering part or lead terminal might be damaged if applying vibration, shock and stress such as pinch, tip, push and twist after installed.
12. Soldering
If next each item is not minded, it may cause deteriorating of its performance, leakage, shortening lifetime.
 - Don't contact solder iron to a cell body.
 - Don't solder over solder conditions in the spec. sheet.
 - Don't charge/discharge before reflow.※The use of the soldering iron is outside the guarantee of this product.
13. Mind cleaning condition when cleaning circuit-board after soldering.
Cleaning may affect PAS capacitor. Consult us about cleaning conditions beforehand.
Some cleaning conditions cause detrimental influence.
14. Storage
Keep following cautions for storage of PAS capacitor
 - Don't store in the high temperature and the high humidity condition and a place where receiving direct sunlight. Storing PAS capacitor in the room condition of 10°C - 35°C and less than 65% relative humidity is recommended. Sudden temperature change or high humidity may cause deteriorating of its characteristics and Soldering.
 - Don't store PAS capacitor near water, salt water or oil, and it the dew condensation, gasified oil or salinity filled place.
 - Don't store PAS capacitor in the hazardous gas (hydrogen sulfide, sulfurous, chlorine, ammonia, bromine, methyl bromine and etc) .
 - Don't fumigate by halogen fumigant.
 - Don't store PAS capacitor near acid or alkaline solvent.
 - Don't store PAS capacitor in a place where exposed to ozone, ultraviolet or x-ray.
 - Don't store PAS capacitor in a place where vibration and shock might occur in.

15. Disposal

Dispose PAS capacitor in accordance with local and country rules and regulations.

16. Usage

PAS capacitor is developed on the assumption of the memory-backup & RTC for usage of information & communication equipment, home electronics, audio & visual equipment, office equipment and etc. Consult us about using high reliability and safety required products such as medical equipment, transportation equipment, industrial equipment, flight / space equipment and emergency equipment.

17. Other Notice

- Don't heat or throw PAS capacitor into fire.
 - Don't short circuit.
 - Don't solder directly to a cell body.
 - Don't open a body.
 - Don't deform.
 - Don't apply pressure.
-