

## Notice for TAIYO YUDEN products

---

Please read this notice before using the TAIYO YUDEN products.

### REMINDERS

- Product information in this catalog is as of October 2013. All of the contents specified herein are subject to change without notice due to technical improvements, etc. Therefore, please check for the latest information carefully before practical application or usage of the Products.

Please note that TAIYO YUDEN CO., LTD. shall not be responsible for any defects in products or equipment incorporating such products, which are caused under the conditions other than those specified in this catalog or individual specification.

- Please contact TAIYO YUDEN CO., LTD. for further details of product specifications as the individual specification is available.

- Please conduct validation and verification of products in actual condition of mounting and operating environment before commercial shipment of the equipment.

- All electronic components or functional modules listed in this catalog are developed, designed and intended for use in general electronics equipment.(for AV, office automation, household, office supply, information service, telecommunications, (such as mobile phone or PC) etc.). Before incorporating the components or devices into any equipment in the field such as transportation,( automotive control, train control, ship control), transportation signal, disaster prevention, medical, public information network (telephone exchange, base station) etc. which may have direct influence to harm or injure a human body, please contact TAIYO YUDEN CO., LTD. for more detail in advance.

Do not incorporate the products into any equipment in fields such as aerospace, aviation, nuclear control, submarine system, military, etc. where higher safety and reliability are especially required.

In addition, even electronic components or functional modules that are used for the general electronic equipment, if the equipment or the electric circuit require high safety or reliability function or performances, a sufficient reliability evaluation check for safety shall be performed before commercial shipment and moreover, due consideration to install a protective circuit is strongly recommended at customer's design stage.

- The contents of this catalog are applicable to the products which are purchased from our sales offices or distributors (so called "TAIYO YUDEN' s official sales channel").

It is only applicable to the products purchased from any of TAIYO YUDEN' s official sales channel.

- Please note that TAIYO YUDEN CO., LTD. shall have no responsibility for any controversies or disputes that may occur in connection with a third party's intellectual property rights and other related rights arising from your usage of products in this catalog. TAIYO YUDEN CO., LTD. grants no license for such rights.

- Caution for export

Certain items in this catalog may require specific procedures for export according to "Foreign Exchange and Foreign Trade Control Law" of Japan, "U.S. Export Administration Regulations", and other applicable regulations. Should you have any question or inquiry on this matter, please contact our sales staff.

# CERAMIC TYPE POLYACENE CAPACITORS



REFLOW

## FEATURES

- High capacity / High reliability  
Polyacene Capacitors can store a large number of ions into its amorphous structure (doping), therefore Polyacene Capacitors has much larger capacitance than conventional electric double layer capacitor. In addition, Polyacene Capacitors is extremely stable material and Polyacene Capacitors shows excellent performance in cycle life and durability to overcharge and overdischarge.
- RoHS / WEEE compliance  
Polyacene Capacitors are RoHS and WEEE compliant products and have no recycling and collection duty that is required in lithium ion battery's case.
- Reflowable with lead-free condition  
(Refer to Reliability Data for recommendable reflow pattern)

## APPLICATIONS

- Memory and RTC back-up power source used for cellular phone, PDA, digital camera, portable radio and so on.

## ORDERING CODE

P A S 3 2 2 5 P  $\triangle$  2 R 6 1 4 3

1	2	3	4	5
1 Series name	2 Dimension (mm)	3 Shape	4 Voltage	5 Nominal Capacitance
PAS Polyacene Capacitors	3225 3.2×2.5	P $\triangle$ Chip Type $\triangle$ =Blank space	2R6 2.6V 3R3 3.3V *R=Decimal point	143 0.014F 113 0.011F

## EXTERNAL DIMENSIONS

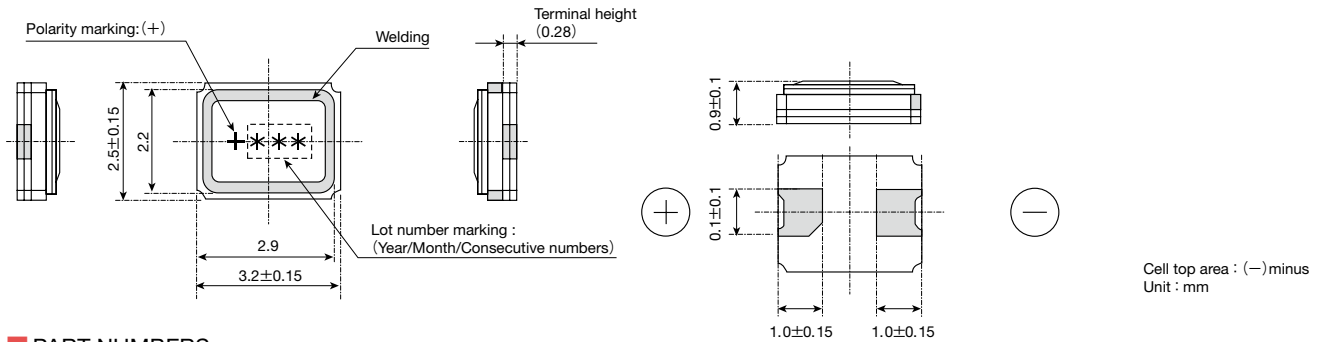

## PART NUMBERS

Part Number	Lead Free Reflowable	RoHS	Maximum Usable Voltage [V]	Normal Capacity [ $\mu$ Ah]	Normal Capacitance [F]	Typical Internal Resistance [ $\Omega$ ]
PAS3225P 2R6143	○	○	2.6	5.0 <sup>*1</sup>	0.014	80
PAS3225P 3R3113	○	○	3.3	4.0 <sup>*2</sup>	0.011	200

\*1 Capacity is measured from maximum usable voltage to 2.0V \*2 Capacity is measured from maximum usable voltage to 2.0V

## SPECIFICATIONS

Part Number	PAS3225P 2R6143	PAS3225P 3R3113
1. Operating Temp. Range	-30~+70°C	-20~+70°C
2. Max. Usable Voltage (V)	2.6V	3.3V
3. Initial Capacitance (F)	Over 0.0105	Over 0.007
4. Initial Capacity ( $\mu$ Ah)	Over 3.5	Over 3.2
5. Initial Internal Resistance ( $\Omega$ )	Under 300	Under 700
6. Max. Discharge Current ( $\mu$ A)	10	10
7. Temperature Characteristics	Highest temperature	Over 60% of Initial Spec
	Lowest temperature	Over 70% of Initial Spec

► This catalog contains the typical specification only due to the limitation of space. When you consider the purchase of our products, please check our specification. For details of each product (characteristics graph, reliability information, precautions for use, and so on), see our Web site (<http://www.ty-top.com/>).

RELIABILITY DATA

Items	Specifications		Test Conditions, Remark
	PAS3225P 2R6143	PAS3225P 3R3113	
1. Operating Temperature range	-30°C~+70°C	-20°C~+70°C	
2. Max. Usable Voltage	2.6V	3.3V	
3. Resistance to Reflow Soldering Heat	Capacity/Capacitance : Within initial spec. Appearance : No noticeable abnormality		Conduct reflow soldering twice according to the reflow soldering test condition mentioned below. (Conduct the reflow in the condition of the voltage of 0.3V or lower.)
4. Floating Charge Characteristics	Capacity/Capacitance : Over 70% of initial spec. Appearance : No noticeable abnormality		Apply a max.usage voltage to the capacitor for 500 hours at max. operating temp. and measure the floating charge characteristics after returning to normal temperature and humidity.
5. Charge/Discharge Cycle Characteristics	Capacity/Capacitance : Over 80% of initial spec. Appearance : No noticeable abnormality		Measure the charge/discharge cycle characteristics after the 10000 cycles of charge/discharge at 25±5 °C with the charge/discharge cycle test condition for each part.
6. Thermal Durability	Capacity/Capacitance : Over 80% of initial spec. Appearance : No noticeable abnormality		Leave the capacitor in an atmosphere of 85°C±2°C and -30±2°C consecutively for 96 hours each, and return to normal temperature and humidity.
7. Humidity Durability	Capacity/Capacitance : Over 80% of initial spec. Appearance : No noticeable abnormality		Temperature : 40±2°C, Humidity : 90~95%RH Leave the capacitor for under the condition for 96hours then return to normal temperature and humidity.
8. Vibration Durability	No exterior abnormality observed : initial spec. values retained		Apply a sine wave vibration of 1.5mm amplitude at frequency 10~55Hz, for 2hours per each direction (X,Y and Z) , for 6 hours in total.

● Reflow Soldering Test Condition

Reflow profile with lead free condition

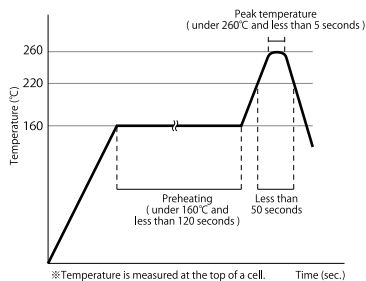

Cautions : Do not charge prior to reflow,  
Set reflow condition within the range provided in "Specifications", which will be published separately.  
Consult with us about the details.

● Charge/Discharge Cycle Test Condition

	PAS3225P 2R6143	PAS3225P 3R3113
Charging/Discharging Resistance (Ω)	300	300
Charging Voltage (V)	2.6	3.3
Charging Time (min.)	4.5	4.5
Discharging Time (min.)	0.5	0.5

► This catalog contains the typical specification only due to the limitation of space. When you consider the purchase of our products, please check our specification. For details of each product (characteristics graph, reliability information, precautions for use, and so on), see our Web site (<http://www.ty-top.com/>) .

# CERAMIC TYPE PAS CAPACITOR

## PACKAGING

### ① Packaging Specifications

Item	Quantity per Reel	Tape Width	Pitch	Reel Diameter
PAS3225P 2R6143	10000	8.0±0.3	4.0±0.1	φ330±2
PAS3225P 3R3113	10000	8.0±0.3	4.0±0.1	φ330±2

Unit : mm

### ② Taping Dimensions

#### ● Emboss Shape

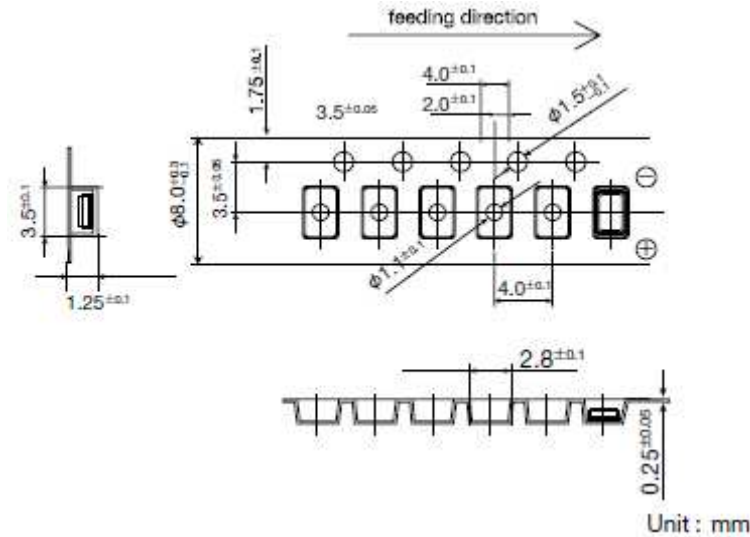

Unit : mm

### ③ Leader Section/Trailer Section

Leader section :Over 400mm(Containing at least 88 vacant pockets of carrier tape sealed with top cover tape)

Trailer section :Over 40mm(Over 10 vacant pockets of carrier tape sealed with top cover tape)

### ④ Reel Size

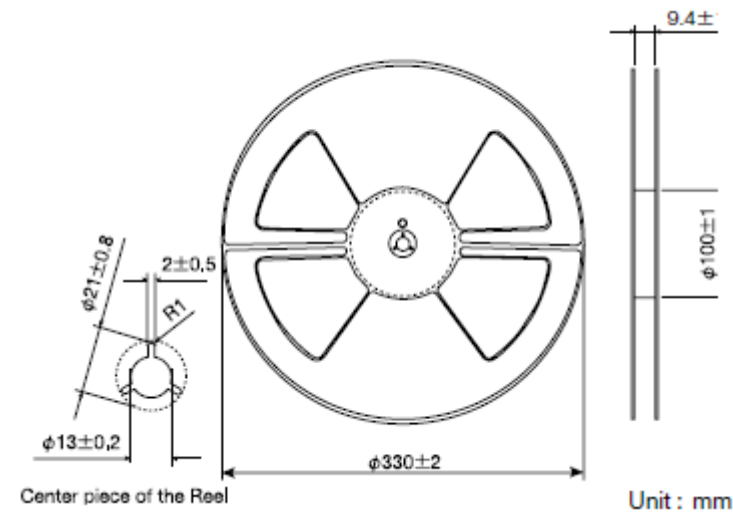

Unit : mm

### ⑤ Peel Strength

0.1~0.7N under the condition of the figure below.

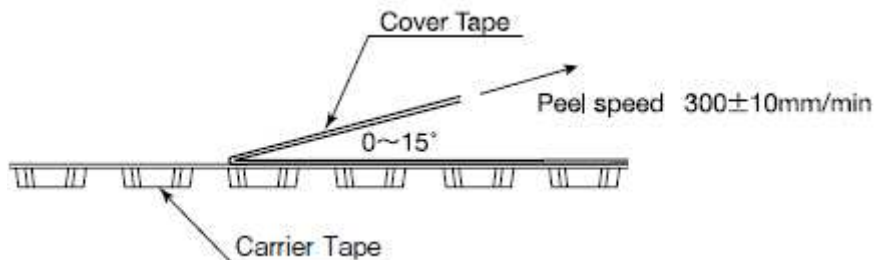

▶ This catalog contains the typical specification only due to the limitation of space. When you consider the purchase of our products, please check our specification. For details of each product (characteristics graph, reliability information, precautions for use, and so on), see our Web site (<http://www.ty-top.com/>).

# CERAMIC TYPE PAS CAPACITOR

## RELIABILITY DATA

1. Operating Temperature range																										
Specified Value	PAS3225P 2R6143	-30°C ~ +70°C																								
	PAS3225P 3R3113	-20°C ~ +70°C																								
2. Max. Usable Voltage																										
Specified Value	PAS3225P 2R6143	2.6V																								
	PAS3225P 3R3113	3.3V																								
3. Resistance to Reflow Soldering Heat																										
Specified Value	PAS3225P 2R6143	Capacity/Capacitance	: Within initial spec.																							
	PAS3225P 3R3113	Appearance	: No noticeable abnormality																							
Test Methods and Remarks	Conduct reflow soldering twice according to the reflow soldering test condition mentioned below. (Conduct the reflow in the condition of the voltage of 0.3V or lower.)																									
	<div style="border: 1px solid black; padding: 5px;"> <p>Reflow Soldering Test Condition</p> <p>Reflow profile with lead free condition</p> <p>Peak temperature (under 260°C and less than 5 seconds)</p> <p>Preheating (under 160°C and less than 120 seconds)</p> <p>Less than 50 seconds</p> <p>※Temperature is measured at the top of a cell. Time (sec.)</p> </div> <p>Cautions : Do not charge prior to reflow, Set reflow condition within the range provided in "Specifications", which will be published separately. Consult with us about the details.</p>																									
4. Floating Charge Characteristics																										
Specified Value	PAS3225P 2R6143	Capacity/Capacitance	: Over 70% of initial spec.																							
	PAS3225P 3R3113	Appearance	: No noticeable abnormality																							
Test Methods and Remarks	Apply a max.usage voltage to the capacitor for 500 hours at max. operating temp. and measure the floating charge characteristics after returning to normal temperature and humidity.																									
5. Charge/Discharge Cycle Characteristics																										
Specified Value	PAS3225P 2R6143	Capacity/Capacitance	: Over 50% of initial spec.																							
	PAS3225P 3R3113	Appearance	: No noticeable abnormality																							
Test Methods and Remarks	Measure the charge/discharge cycle characteristics after the 10000 cycles of charge/discharge at 25±5 °C with the charge/discharge cycle test condition for each part.																									
	<table border="1"> <thead> <tr> <th colspan="4">Charge/Discharge Cycle Test Condition</th> </tr> <tr> <th>Part Number</th> <th>PAS3225P 2R6143</th> <th colspan="2">PAS3225P 3R3113</th> </tr> </thead> <tbody> <tr> <td>Charging/Discharging Resistance (Ω)</td> <td>300</td> <td colspan="2">300</td> </tr> <tr> <td>Charging Voltage (V)</td> <td>2.6</td> <td colspan="2">3.3</td> </tr> <tr> <td>Charging Time (min.)</td> <td>4.5</td> <td colspan="2">4.5</td> </tr> <tr> <td>Discharging Time (min.)</td> <td>0.5</td> <td colspan="2">0.5</td> </tr> </tbody> </table>			Charge/Discharge Cycle Test Condition				Part Number	PAS3225P 2R6143	PAS3225P 3R3113		Charging/Discharging Resistance (Ω)	300	300		Charging Voltage (V)	2.6	3.3		Charging Time (min.)	4.5	4.5		Discharging Time (min.)	0.5	0.5
Charge/Discharge Cycle Test Condition																										
Part Number	PAS3225P 2R6143	PAS3225P 3R3113																								
Charging/Discharging Resistance (Ω)	300	300																								
Charging Voltage (V)	2.6	3.3																								
Charging Time (min.)	4.5	4.5																								
Discharging Time (min.)	0.5	0.5																								

6. Thermal Durability		
Specified Value	PAS3225P 2R6143	Capacity/Capacitance : Over 80% of initial spec. Appearance : No noticeable abnormality
	PAS3225P 3R3113	
Test Methods and Remarks	Leave the capacitor in an atmosphere of $85^{\circ}\text{C} \pm 2^{\circ}\text{C}$ and $-30 \pm 2^{\circ}\text{C}$ consecutively for 96 hours each, and return to normal temperature and humidity.	

7. Humidity Durability		
Specified Value	PAS3225P 2R6143	Capacity/Capacitance : Over 80% of initial spec. Appearance : No noticeable abnormality
	PAS3225P 3R3113	
Test Methods and Remarks	Temperature : $40 \pm 2^{\circ}\text{C}$ , Humidity : 90~95%RH Leave the capacitor for under the condition for 96hours then return to normal temperature and humidity.	

8. Vibration Durability		
Specified Value	PAS3225P 2R6143	No exterior abnormality observed :initial spec. values retained
	PAS3225P 3R3113	
Test Methods and Remarks	Apply a sine wave vibration of 1.5mm amplitude at frequency 10~55Hz, for 2hours per each direction (X,Y and Z) , for 6 hours in total.	

# CERAMIC TYPE PAS CAPACITOR

---

## ■ PRECAUTIONS

---

1. Use under the maximum usable voltage  
When voltage which exceed the maximum usable voltage is applied, it might cause abnormal current flow, which shorten lifetime, and leakage , and sometimes damages PAS capacitors.
2. Use under maximum operating temperature  
A capacitor using in over max operating temperature may lead to shorter life, leakage, and electrical damage by increasing internal pressure.
3. Limited lifetime  
Lifetime of PAS capacitor is greatly affected by surrounding temperature. If the temperature lowered by 10°C, the lifetime will approximately doubled. Design a circuit under consideration of deterioration of electrical characteristics after long time usage, i.e. decrease in capacitance and increase in internal resistance.
4. PAS capacitor's electrical characteristics might change depending on the surrounding temperature  
PAS Capacitor's electrical characteristics might change depending on the surrounding temperature aside from aged deterioration. Therefore, be sure to confirm the temperature performance before use product.
5. PAS capacitor has polarity  
PAS capacitor has polarity. Please check the polarity before use.  
If a reverse voltage is applied, causing damage to the product.
6. Mind high ripple current or rapid charge / discharge  
In circuit with high ripple current or rapid charge / discharge, the lifetime of PAS capacitors might be shortened by self-heating.
7. Mind voltage drop when back-up  
When back-up (discharging) starts, voltage will drop because of active current and internal resistance.
8. Series connection  
In case of using PAS capacitor in series connection, the voltage of each capacitor is not always equal and it may be occurred excessive voltage in a part of capacitor, which may lead to shortening lifetime and breakdown. Take a margin against a rated voltage or add a balancing resistance.
9. Don't contact with wiring pattern during installing  
If PAS capacitor contact with wiring pattern, it may causes short-circuit, and if there is wiring pattern underneath of PAS capacitor, short circuit would occur by damage of resist.
10. Environment of usage  
In case PAS capacitor is used in high humidity, alkaline or acid air, it may cause deteriorating of its performance and short circuit by corrosion of outer can or terminal. In addition, used in sudden temperature change or high humidity, it may cause deteriorating of its performance and electrolyte leak by dew condensation.
11. Don't apply shock and vibration or pressure  
PAS capacitor is sensitive to shock. Don't drop PAS capacitor and not apply strong pressure to a body, terminals. Soldering part or terminal might be damaged if applying vibration, shock and stress such as pinch, tip, push and twist after installed.
12. Soldering  
If next each item is not minded, it may cause deteriorating of its performance, leakage, and shortening lifetime.
  - Don't contact solder iron to a cell body.
  - Don't solder over solder conditions in the soldering test condition sheet.
  - Don't charge/discharge before reflow
13. Mind cleaning condition when cleaning circuit-board after soldering  
Cleaning may affect PAS capacitor. Consult us about cleaning conditions beforehand.  
Some cleaning conditions cause detrimental influence.
14. Storage  
Keep following cautions for storage of PAS capacitor.
  - Don't store in high temperature and high humidity condition and a place where receiving direct sunlight. Storing PAS capacitor in the room condition of 10 °C – 35 °C and less than 65% relative humidity is recommended.
  - Sudden temperature change or high humidity may cause deteriorating of its characteristics and soldering.
  - Don't store PAS capacitor near water, salt water or oil, and dew condensation, gasified oil or salinity filled place.
  - Don't store PAS capacitor in the hazardous gas (hydrogen sulfide, sulfurous, chlorine, ammonia, bromine, methyl bromine and etc.) .
  - Don't fumigate by halogen fumigant.
  - Don't store PAS capacitor near acid or alkaline solvent.
  - Don't store PAS capacitor in a place where exposed to ozone, ultraviolet or x-ray.
  - Don't store PAS capacitor in a place where vibration and shock might occur.

---

15. Disposal

Dispose PAS capacitor in accordance with local and country rules and regulations.

16. Usage

This product is developed, designed and intended for use in general electronics equipment (for information service, home electric appliances, audio and visual equipment, RTC & memory back up for consumer product and institutional use).

Please consult the manufacturer in advance when the capacitor is used in devices such as: medical devices; transportation devices; industrial devices; aerospace industrial devices; security devices and disaster prevention devices.

17. Other Notice

- Don't heat or throw PAS capacitor into fire.
  - Don't short circuit.
  - Don't solder directly to a cell body.
  - Don't open a body.
  - Don't deform.
-