

DIGITAL OUTPUT PRESSURE SENSORS

Enhanced Digital Output Sensors

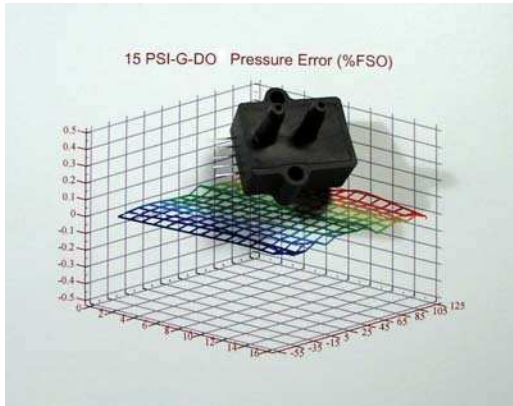

Features

- 5" H₂O to 100psi Pressure Ranges
- All Combined Errors Over Temperature Less Than 0.1%, Typical
- Wide -20 to 85°C Compensated Temperature Range
- Electrically Compatible to All Sensors GA142 Series
- Enhanced Dual Serial Interface Mode

Applications

- Medical Instrumentation
- Environmental Controls
- HVAC
- Meteorology

General Description

The Digital Output pressure sensors are based upon a proprietary surface mapping technology to produce a fully digital output that virtually eliminates all repeatable errors over temperature and pressure. This series provides a 12 bit digital serial output (14 bit in High Resolution Mode) with superior offset, span and linearity characteristics. The output is SPI and MICROWIRE/PLUS[®] compatible as well as fully compatible with the All Sensors GA142 Series sensors.

In addition to synchronous communications, the Digital Output pressure sensors incorporates a bi-directional, TTL level, asynchronous serial interfaces mode (hardware selectable 9,600 or 19,200 baud). This mode includes a command set that allows the host to interrogate the sensor for model information, pressure range, serial number, pressure units and conversion factor. The command set also allows the host to select a high resolution output mode, make minor adjustments to offset and has an addressable feature that allows multiple sensors to be tied to the same interface buss.

This series is intended for use with non-corrosive, non-ionic working fluids such as air, dry gases and the like. All signals are 5V TTL/CMOS compatible.

Physical Dimensions

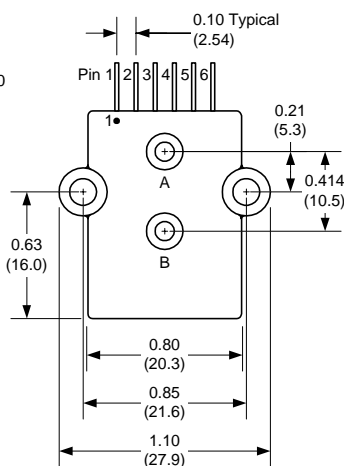
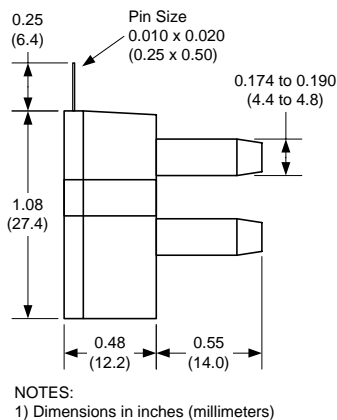

Pin Descriptions

Pin	Label	Description
1	Vcc	+5V power supply input
2	Data/SI	Data output for synchronous mode. Serial in for asynchronous mode.
3	Clock/SO	Clock output for synchronous mode. Serial out for asynchronous mode.
4	Ready/Mode	Ready output for synchronous mode. Selects asynchronous mode when held low during reset.
5	Convert/BR	Convert input for synchronous mode. Selects one of two baud rates for asynchronous mode (low=9,600, high=19,200).
6	Ground	Ground for power and signals



Absolute Maximum Ratings

Supply Voltage (Vcc)	7Vdc
Voltage on Any Pin with Respect to Gnd	-0.6 to Vcc+0.6V
Common-mode pressure	50 psig
Lead Temperature (soldering 2-4 sec.)	250°C

Environmental Specifications

Operating Voltage	+4.75Vdc to +5.25Vdc
Compensated Temperature	-20°C to +85°C
Operating Temperature	-25 to +90°C
Storage Temperature	-40 to 125°C
Humidity Limits	0 to 95% RH (non condensing)

Standard Pressure Ranges

Part Number	Operating Pressure	Units	FSO ⁽²⁾	Digital Span ⁽⁴⁾	Proof Pressure	Burst Pressure
5 INCH-D-DO	-5 to 5	inH2O	5	1	200inH2O	300inH2O
10 INCH-D-DO	-10 to 10	inH2O	10	1	200inH2O	300inH2O
1 PSI-D-DO	-1 to 1	PSI	1	1	200inH2O	300inH2O
5 PSI-D-DO	-5 to 5	PSI	5	1	10 PSI	30 PSI
15 PSI-D-DO	-15 to 15	PSI	15	1	60 PSI	120 PSI
15 PSI-A-DO	0 to 15	PSIA	15	2	60 PSI	120 PSI
30 PSI-D-DO	-30 to 30	PSI	30	2	90 PSI	150 PSI
30 PSI-A-DO	0 to 30	PSIA	30	2	90 PSI	150 PSI
100 PSI-D-DO	-100 to 100	PSI	100	2	200 PSI	250 PSI
100 PSI-A-DO	0 to 100	PSIA	100	2	200 PSI	250 PSI

General Performance Characteristics (All Models)

Parameter ⁽¹⁾	Minimum	Nominal	Maximum	Units
Resolution	12	--	--	Bit
Conversion Speed	--	8	16	mS
Supply Current	--	8	12	mA

Performance Characteristics for 5 INCH-D-DO

Parameter ⁽¹⁾	Minimum	Nominal	Maximum	Units
Overall Accuracy ⁽⁵⁾	--	0.25	0.5	%FSO
Long Term Drift (one year)	--	--	0.5	%FSO
Offset Position Sensitivity (1g)	--	--	0.05	%FSO
Offset Warm-up Shift ⁽³⁾	--	--	0.25	%FSO

Performance Characteristics for 10 INCH-D-DO and 1 PSI-D-DO

Parameter ⁽¹⁾	Minimum	Nominal	Maximum	Units
Overall Accuracy ⁽⁵⁾	--	0.25	0.5	%FSO
Long Term Drift (one year)	--	--	0.5	%FSO
Offset Position Sensitivity (1g)	--	--	0.03	%FSO
Offset Warm-up Shift ⁽³⁾	--	--	0.25	%FSO

Performance Characteristics for 5 PSI-D-DO through 100 PSI-x-DO

Parameter ⁽¹⁾	Minimum	Nominal	Maximum	Units
Overall Accuracy ⁽⁵⁾	--	0.10	0.25	%FSO
Long Term Drift (one year)	--	--	0.25	%FSO

Specification Notes

NOTE 1: UNLESS OTHERWISE SPECIFIED, ALL PARAMETERS ARE MEASURED AT 5.0 VOLT SUPPLY, POSITIVE PRESSURE APPLIED TO PORT B.

NOTE 2: THE DIGITAL OUTPUT IS A 16 BIT SIGNED BINARY OUTPUT IN A TWO'S COMPLEMENT FORMAT. THE APPLIED PRESSURE IS COMPUTED USING THE PRESSURE CONVERSION TABLE (BELOW). THE MODE COLUMN IDENTIFIES THE RESOLUTION OPERATING MODE OF THE DEVICE (A = STANDARD RESOLUTION, B = HIGH RESOLUTION). FSO AND UNITS ARE SHOWN FOR EACH MODEL.

NOTE 3: SHIFT IS WITHIN THE FIRST HOUR OF EXCITATION APPLIED TO THE DEVICE.

NOTE 4: DIGITAL SPAN IS DEPENDENT ON THE RESOLUTION OPERATING MODE. REFER TO THE DIGITAL SPAN TABLE (BELOW) TO IDENTIFY THE DIGITAL SPAN OF THE SPECIFIC MODEL. IN THE EVENT OF AN OVER-PRESSURE OR UNDER-PRESSURE CONDITION, THE DIGITAL OUTPUT WILL ONE COUNT HIGHER OR ONE COUNT LOWER (RESPECTIVELY) TO THE LISTED DIGITAL SPAN TO INDICATE THE CONDITION.

NOTE 5: OVERALL ACCURACY INCLUDES THE COMBINED EFFECTS OF OFFSET AND SPAN SHIFTS OVER TEMPERATURE, LINEARITY, HYSTERESIS, AND OFFSET AND SPAN CALIBRATION.

Synchronous Timing Diagram (Note: Asynchronous mode timing is per RS-232. To use RS-232 requires the Maxim MA232 interface circuit for proper voltage level compatibility.)

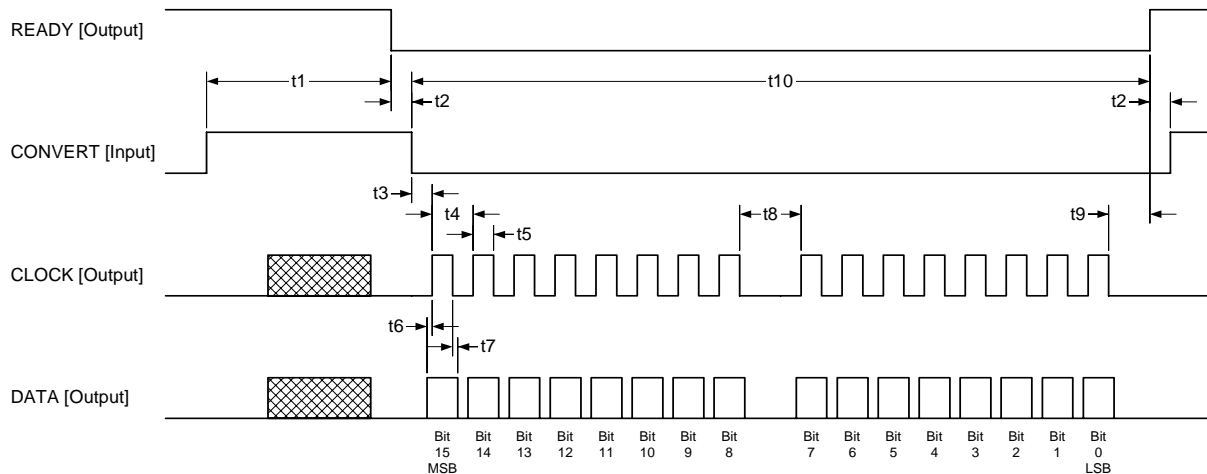

Ref	Parameter	Min	Typ	Max	Units
t1	Conversion Time	--	8	16	msec
t2	Ready to Convert	0	--	--	usec
t3	Convert to Clock	24	32	39	usec
t4	Clock Period	--	24	--	usec
t5	Clock High Time	--	12	--	usec

Ref	Parameter	Min	Typ	Max	Units
t6	Data Setup Time	--	3	--	usec
t7	Data Hold Time	--	3	--	usec
t8	Interbyte Delay	--	70	--	usec
t9	Clock to Ready	--	14	--	usec
t10	Data Transmission	--	476	--	usec

Typical Configurations

Synchronous Communications

Typical synchronous communications configuration (compatible with All Sensors GA142 Series Digital Output Sensors).

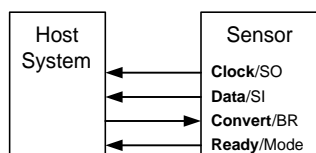

Asynchronous Communications

Typical asynchronous communications configuration. The Mode pin is interrogated at power up and if tied low, will cause the sensor to enter asynchronous communications mode. This mode supports multiple sensors by addressable commands. The Convert/BR pin then serves to select one of two available baud rates.

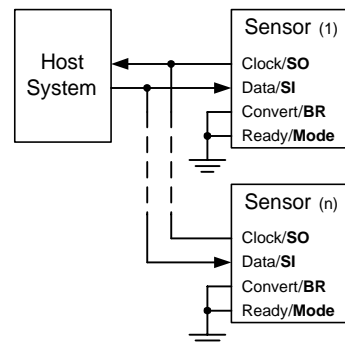

Command Summary Table:

Command	Description	Response
RA<cr>	Read Accuracy String	RA=[Accuracy String]<cr>
RC<cr>	Read Captured Pressure	RC=[hhh]<sp>[eeee]<cr>
RH<cr>	Read High Resolution Pressure	RH=[hhh]<sp>[eeee]<cr>
RL<cr>	Read Low Resolution Pressure	RL[IIII]<sp>[eeee]<cr>
RM<cr>	Read Model	RM=[Model String]<cr>
RR<cr>	Read Pressure Range	RR=[pressure Range String]<cr>
RS<cr>	Read Serial Number	RS=[S/N String]<cr>
RT<cr>	Read Temperature	RT=[Temperature Range String]<cr>
U[S/N String][Command]<cr>	Unique Command	For Matching S/N U[S/N String],sp>[Response String] For Non-matching S/N {null}
WC<cr>	Capture Pressure	{null}

Notations:

<> indicates a single ascii character

[] indicates an ascii string

{ } text within the braces describes the response (this is essentially a comment)

"" text within quotes represents a literal ascii text string

Definitions:

Term	Name	Description
<cr>	Carriage Return	ascii Carriage Return. This is a command/response delimiter
<sp>	Space	ascii Space Character
[Accuracy String]	Accuracy String	Part accuracy string. Given in % full scale output. Example: 0.250%FSO Notes: 1.) There is a space between the numeric accuracy "0.250" and units "%FSO." 2.) FSO stands for Full Scale Output (full scale output is determined by the Pressure Range String.)
[hhh]	High Resolution Output	This is a four character ascii string representing a hexadecimal value. Example: 3F7C Represents an output count of 16,252 Note: the output is forced to "8000" upon an error. except error bit 8, see error bit codes.
[IIII]	Low Resolution Output	This is a four character ascii string representing a hexadecimal value. Example: 1D58 Represents an output count of 7,512 Note: the output is forced to "8000" upon an error. except error bit 8, see error bit codes.
[Model String]	Model String	Part Model as given in the data sheet (also order number.) The general model syntax is [Full Scale Pressure]<sp>[Pressure Units]-[Pressure Model]-DO Example: 100 PSI-D-DO Where: Full Scale Pressure=100 Pressure Units=PSI (inH2O, mbar or mmHg available) DO represents Digital Output Notes: 1.) Exception to this syntax is the Barometer. 2.) Custom models may be different.

Definitions

Term	Name	Description		
[Pressure Range String]	Pressure Range String	This is the compensated pressure range of the part. Syntax: [low limit]<sp>"to"<sp>[high limit]<sp>[units][mode] Example: 20 to 32 mmHgA Where: Low limit = 20 High limit = 32 Units = mmHg Mode = A (absolute pressure) (D differential and G gage pressure also available.)		
[Response String]	A Fully Formed Response String	Example: "RL=1E43<sp>0000<cr>		
[S/N String]	Serial Number String	<table border="1"> <tr> <td> YMDD-NN-BSPP (12 character String) Where: Y : Year (0~9) M : Month (A~M, excluding I) DD: Day of Month NN: Lot (lot sequence for a given day) B : Lot Batch# (A~Z) S : Test Oven Slot# (1~5) P : Position on Slot (1~15) Example: 3D23-03-A103 April 23, 2003 3rd lot of the day Batch A, Slot 1, Position 03 This allows traceability to original test data </td> <td> Month Codes January : A February : B March : C April : D May : E June : F July : G August : H September : J October : K November : L December : M </td> </tr> </table>	YMDD-NN-BSPP (12 character String) Where: Y : Year (0~9) M : Month (A~M, excluding I) DD: Day of Month NN: Lot (lot sequence for a given day) B : Lot Batch# (A~Z) S : Test Oven Slot# (1~5) P : Position on Slot (1~15) Example: 3D23-03-A103 April 23, 2003 3rd lot of the day Batch A, Slot 1, Position 03 This allows traceability to original test data	Month Codes January : A February : B March : C April : D May : E June : F July : G August : H September : J October : K November : L December : M
YMDD-NN-BSPP (12 character String) Where: Y : Year (0~9) M : Month (A~M, excluding I) DD: Day of Month NN: Lot (lot sequence for a given day) B : Lot Batch# (A~Z) S : Test Oven Slot# (1~5) P : Position on Slot (1~15) Example: 3D23-03-A103 April 23, 2003 3rd lot of the day Batch A, Slot 1, Position 03 This allows traceability to original test data	Month Codes January : A February : B March : C April : D May : E June : F July : G August : H September : J October : K November : L December : M			
[Temperature Range String]	Temperature Range String	This is the compensated temperature range of the part. Syntax: [low limit]<sp>[high limit]<sp>"C" Example: -20 to 85 C -40 to 125 C and custom ranges also available.		
[eeee]	Error Codes	<p>The error codes are bitpacked within a double byte. The four character string is an ascii hex expression. The error code bits are:</p> <ul style="list-style-type: none"> Bit 0 : Part not factory compensated Bit 1 : Tdex Overflow Bit 2 : Tdex Over-range Bit 3 : Pdex Overflow Bit 4 : Pdex Over-range Bit 5 : PWL Overflow Bit 6 : Scale Overflow Bit 7 : High Resolution Overflow Bit 8 : Pressure Output Limited to Specific Value Bits 9 through 15 : Reserved <p>Example: 0100 Represents erro bit 8 set and the Pressure Output Limited</p> <p>Notes: Bit 0 : This should not appear if the part has been calibrated Bits 1 thru 7 : indicate computational error when compensated Bit 8 : indicates that the pressure applied to the part exceeds the range of the part and is limit to either the high or low limit</p>		
{null}	Null Response	No response from the part. In the event of a serial number mismatch the part will not respond (to avoid buss contention.)		

All Sensors reserves the right to make changes to any products herein. All Sensors does not assume any liability arising out of the application or use of any product or circuit described herein, neither does it convey any license under its patent rights nor the rights of others.

© MICROWIRE/PLUS IS A REGISTERED TRADEMARK OF NATIONAL SEMICONDUCTOR.

