

# Amplified Low Pressure Sensors

1 mbar (0.4 In H<sub>2</sub>O) to 30 In H<sub>2</sub>O Pressure Sensors

## Military Temperature Grade

### Features

- 0 to 1 mbar to 0 to 30 In H<sub>2</sub>O Pressure Ranges
- Ratiometric 4V Output
- Temperature Compensated (-40C to 125C)
- Calibrated Zero and Span

### Applications

- Medical Instrumentation
- Environmental Controls
- HVAC



### General Description

The Amplified line of low pressure sensors is based upon a proprietary technology to reduce all output offset or common mode errors. This model provides a ratiometric 4-volt output with superior output offset characteristics. Output offset errors due to change in temperature, stability to warm-up, stability to long time period, and position sensitivity are all significantly reduced when compared to conventional compensation methods. In addition the sensor utilizes a silicon, micromachined, stress concentration enhanced structure to provide a very linear output to measured pressure.

These calibrated and temperature compensated sensors give an accurate and stable output over a wide temperature range. This series is intended for use with non-corrosive, non-ionic working fluids such as air, dry gases and the like.

The output of the device is ratiometric to the supply voltage over a supply voltage range of 4.5 to 5.5 volts.

### Physical Dimensions

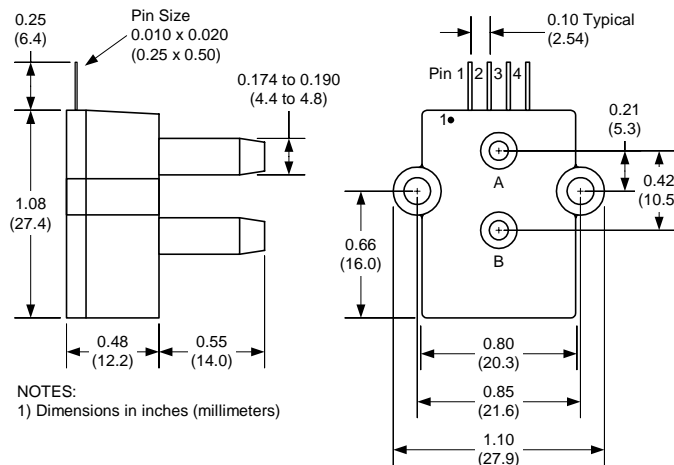

NOTES:  
1) Dimensions in inches (millimeters)

- pin 1: V<sub>supply</sub>
- pin 2: Common
- pin 3: V<sub>output</sub>
- pin 4: do not connect



## Pressure Sensor Ratings

<b>Supply Voltage VS</b>	+4.5 to +5.5 Vdc
<b>Common-mode pressure</b>	-10 to +10 psig
<b>Lead Temperature, max (soldering 2-4 sec.)</b>	250°C

## Environmental Specifications

<b>Temperature Ranges</b>	
<b>Compensated</b>	-40 to 125°C
<b>Operating</b>	-40 to 125°C
<b>Storage</b>	-40 to 125°C
<b>Humidity Limits</b>	0 to 95% RH (non condensing)

## Standard Pressure Ranges

Part Number	Operating Pressure	Nominal Span	Proof Pressure	Burst Pressure
1 MBAR-D-4V-MIL	±1 mbar	4 V	100 In H2O	200 In H2O
1 INCH-D-4V-MIL	±1 In H2O	4 V	100 In H2O	200 In H2O
1 INCH-G-4V-MIL	0 - 1 In H2O	4 V	300 In H2O	200 In H2O
5 INCH-D-4V-MIL	± 5 In H2O	4 V	200 In H2O	300 In H2O
5 INCH-G-4V-MIL	0 - 5 In H2O	4 V	200 In H2O	300 In H2O
10 INCH-D-4V-MIL	±10 In H2O	4 V	200 In H2O	300 In H2O
10 INCH-G-4V-MIL	0 - 10 In H2O	4 V	200 In H2O	300 In H2O
20 INCH-D-4V-MIL	±20 In H2O	4 V	300 In H2O	500 In H2O
20 INCH-G-4V-MIL	0 - 20 In H2O	4 V	300 In H2O	500 In H2O
30 INCH-D-4V-MIL	±30 In H2O	4 V	500 In H2O	800 In H2O
30 INCH-G-4V-MIL	0 - 30 In H2O	4 V	500 In H2O	800 In H2O

## Performance Characteristics for: 1 MBAR-D-4V-MIL

Parameter, NOTE 1	Minimum	Nominal	Maximum	Units
Operating Range, differential pressure		±1.0		mbar
Output Span, NOTE 5	±1.80	±2.0	±2.20	volt
Offset Voltage @ zero differential pressure	2.00	2.25	2.50	volt
Offset Temperature Shift (-40°C-125°C), NOTE 2			±120	mvolt
Offset Warm-up Shift, NOTE 3		±20		mvolt
Offset Position Sensitivity (±1g)		±40		mvolt
Offset Long Term Drift (one year)		±20		mvolt
Linearity, hysteresis error, NOTE 4		0.05	0.25	%fs
Span Shift (-40°C-125°C), NOTE 2			±4	%span

## Performance Characteristics for 1 INCH-D-4V-MIL

Parameter, note 1	Minimum	Nominal	Maximum	Units
Operating Range, differential pressure		±1.0		"H2O
Output Span, note 5	±1.90	±2.0	±2.10	volt
Offset Voltage @ zero differential pressure	2.15	2.25	2.35	volt
Offset Temperature Shift (-40°C-125°C), NOTE 2			±60	mvolt
Offset Warm-up Shift, NOTE 3		±10		mvolt
Offset Position Sensitivity (±1g)		±5		mvolt
Offset Long Term Drift (one year)		±10		mvolt
Linearity, hysteresis error, NOTE 4		0.05	0.25	%fs
Span Shift (-40°C-125°C), NOTE 2			±2	%span

## Performance Characteristics for 1 INCH-G-4V-MIL

Parameter, note 1	Minimum	Nominal	Maximum	Units
Operating Range, gage pressure		1.0		"H2O
Output Span, note 5	3.90	4.0	4.10	volt
Offset Voltage @ zero pressure	0.15	0.25	0.35	volt
Offset Temperature Shift (-40°C-125°C), NOTE 2			±60	mvolt
Offset Warm-up Shift, NOTE 3		±10		mvolt
Offset Position Sensitivity (±1g)		±15		mvolt
Offset Long Term Drift (one year)		±10		mvolt
Linearity, hysteresis error, NOTE 4		0.05	0.25	%fs
Span Shift (-40°C-125°C), NOTE 2			±2	%span

## Performance Characteristics for 5 INCH-D-4V-MIL

Parameter, note 1	Minimum	Nominal	Maximum	Units
Operating Range, differential pressure		±5.0		"H2O
Output Span, note 5	±1.90	±2.0	±2.10	volt
Offset Voltage @ zero differential pressure	2.15	2.25	2.35	volt
Offset Temperature Shift (-40°C-125°C), NOTE 2			±40	mvolt
Offset Warm-up Shift, NOTE 3		±5		mvolt
Offset Position Sensitivity (±1g)		±5		mvolt
Offset Long Term Drift (one year)		±5		mvolt
Linearity, hysteresis error, NOTE 4		0.05	0.25	%fs
Span Shift (-40°C-125°C), NOTE 2			±1	%span



## Performance Characteristics for: 5 INCH-G-4V-MIL

Parameter, NOTE 1	Minimum	Nominal	Maximum	Units
Operating Range, gage pressure		5.0		"H2O
Output Span, NOTE 5	3.90	4.0	4.10	volt
Offset Voltage @ zero pressure	0.15	0.25	0.35	volt
Offset Temperature Shift (-40°C-125°C), NOTE 2			±40	mvolt
Offset Warm-up Shift, NOTE 3		±5		mvolt
Offset Position Sensitivity (±1g)		±5		mvolt
Offset Long Term Drift (one year)		±5		mvolt
Linearity, hysteresis error, NOTE 4		0.05	0.25	%fs
Span Shift (-40°C-125°C), NOTE 2			±1	%span

## Performance Characteristics for: 10 INCH-D-4V-MIL

Parameter, NOTE 1	Minimum	Nominal	Maximum	Units
Operating Range, differential pressure		±10.0		"H2O
Output Span, NOTE 5	±1.90	±2.0	±2.10	volt
Offset Voltage @ zero differential pressure	2.15	2.25	2.35	volt
Offset Temperature Shift (-40°C-125°C), NOTE 2			±20	mvolt
Offset Warm-up Shift, NOTE 3		±5		mvolt
Offset Position Sensitivity (±1g)		±5		mvolt
Offset Long Term Drift (one year)		±5		mvolt
Linearity, hysteresis error, NOTE 4		0.05	0.25	%fs
Span Shift (-40°C-125°C), NOTE 2			±1	%span

## Performance Characteristics for: 10 INCH-G-4V-MIL

Parameter, NOTE 1	Minimum	Nominal	Maximum	Units
Operating Range, gage pressure		10.0		"H2O
Output Span, NOTE 5	3.90	4.0	4.10	volt
Offset Voltage @ zero pressure	0.15	0.25	0.35	volt
Offset Temperature Shift (-40°C-125°C), NOTE 2			±20	mvolt
Offset Warm-up Shift, NOTE 3		±5		mvolt
Offset Position Sensitivity (±1g)		±5		mvolt
Offset Long Term Drift (one year)		±5		mvolt
Linearity, hysteresis error, NOTE 4		0.05	0.25	%fs
Span Shift (-40°C-125°C), NOTE 2			±1	%span

## Performance Characteristics for 20 INCH-D-4V-MIL

Parameter, note 1	Minimum	Nominal	Maximum	Units
Operating Range, differential pressure		±20.0		"H2O
Output Span, note 5	±1.90	±2.0	±2.10	volt
Offset Voltage @ zero differential pressure	2.15	2.25	2.35	volt
Offset Temperature Shift (-40°C-125°C), NOTE 2			±20	mvolt
Offset Warm-up Shift, NOTE 3		±5		mvolt
Offset Position Sensitivity (±1g)		±5		mvolt
Offset Long Term Drift (one year)		±5		mvolt
Linearity, hysteresis error, NOTE 4		0.05	0.25	%fs
Span Shift (-40°C-125°C), NOTE 2			±1	%span

## Performance Characteristics for 20 INCH-G-4V-MIL

Parameter, note 1	Minimum	Nominal	Maximum	Units
Operating Range, gage pressure		20.0		"H2O
Output Span, note 5	3.90	4.0	4.1	volt
Offset Voltage @ zero pressure	0.15	0.25	0.35	volt
Offset Temperature Shift (-40°C-125°C), NOTE 2			±20	mvolt
Offset Warm-up Shift, NOTE 3		±5		mvolt
Offset Position Sensitivity (±1g)		±5		mvolt
Offset Long Term Drift (one year)		±5		mvolt
Linearity, hysteresis error, NOTE 4		0.05	0.25	%fs
Span Shift (-40°C-125°C), NOTE 2			±1	%span

## Performance Characteristics for 30 INCH-D-4V-MIL

Parameter, note 1	Minimum	Nominal	Maximum	Units
Operating Range, differential pressure		±30.0		"H2O
Output Span, note 5	±1.90	±2.0	±2.10	volt
Offset Voltage @ zero differential pressure	2.15	2.25	2.35	volt
Offset Temperature Shift (-40°C-125°C), NOTE 2			±20	mvolt
Offset Warm-up Shift, NOTE 3		±5		mvolt
Offset Position Sensitivity (±1g)		±5		mvolt
Offset Long Term Drift (one year)		±5		mvolt
Linearity, hysteresis error, NOTE 4		0.05	0.25	%fs
Span Shift (-40°C-125°C), NOTE 2			±1	%span



## Performance Characteristics for 30 INCH-G-4V-MIL

Parameter, NOTE 1	Minimum	Nominal	Maximum	Units
Operating Range, gage pressure		30.0		"H2O
Output Span, NOTE 5	3.9	4.0	4.1	volt
Offset Voltage @ zero pressure	0.15	0.25	0.35	volt
Offset Temperature Shift (-40°C-125°C), NOTE 2			±20	mvolt
Offset Warm-up Shift, NOTE 3		±5		mvolt
Offset Position Sensitivity (±1g)		±5		mvolt
Offset Long Term Drift (one year)		±5		mvolt
Linearity, hysteresis error, NOTE 4		0.05	0.25	%fs
Span Shift (-40°C-125°C), NOTE 2			±1	%span

## Equivalent Circuit

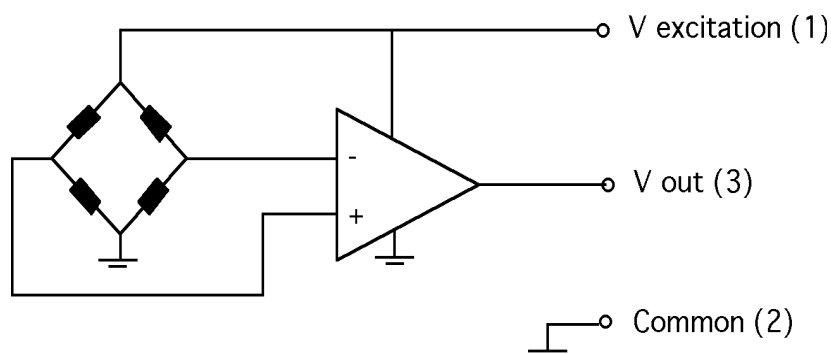

**Pressure Response:** for any pressure applied the response time to get to 90% of pressure applied is typically less than 500 useconds.

### Specification Notes

NOTE 1: ALL PARAMETERS ARE MEASURED AT 5.0 VOLT EXCITATION, FOR THE NOMINAL FULL SCALE PRESSURE AND ROOM TEMPERATURE UNLESS OTHERWISE SPECIFIED. **PRESSURE MEASUREMENTS ARE WITH POSITIVE PRESSURE APPLIED TO PORT B.**

NOTE 2: SHIFT IS RELATIVE TO 25°C.

NOTE 3: SHIFT IS WITHIN THE FIRST HOUR OF EXCITATION APPLIED TO THE DEVICE.

NOTE 4: MEASURED AT ONE-HALF FULL SCALE RATED PRESSURE USING BEST STRAIGHT LINE CURVE FIT.

NOTE 5: THE VOLTAGE ADDED TO THE OFFSET VOLTAGE AT FULL SCALE PRESSURE. NOMINALLY THE OUTPUT VOLTAGE RANGE IS 0.25 TO 4.25 VOLTS FOR MINUS TO PLUS FULL SCALE PRESSURE.

All Sensors reserves the right to make changes to any products herein. All Sensors does not assume any liability arising out of the application or use of any product or circuit described herein, neither does it convey any license under its patent rights nor the rights of others.