

# IF series

Sealed pushbutton switches with Ø 25 mm actuator - bushing dia. 16 mm

- Can be operated with gloved hands
- Snap-in and threaded bushing models
- Resistant to frost
- Sealed to IP54 or IP67

## ELECTRICAL AND GENERAL SPECIFICATIONS

- Max. current/voltage rating with resistive load : 400mA 32VAC - 100mA 48VDC
- Initial contact resistance : 50 mΩ max.
- Insulation resistance : 1 GΩ min. at 500VDC
- Dielectric strength : 1.000 VAC rms. between terminals and frame  
1500 VAC between terminals
- Electrical life at full load : 500.000 cycles
- Panel thickness:
  - Snap-in models : 0,8 mm (.031) min. - 2,5 mm (.098) max.
  - Threaded bushing models : 0,8 mm (.031) min. - 5 mm (.196) max.
- Total travel : 4 mm (.157)
- Typical operating force : 6,5 N +/- 2N
- Low level or mechanical life : 1.000.000 cycles
- Torque : 1,5 Nm max. applied to nut
- Soldering : 320°C max. for 3 seconds

## MATERIALS

- Case : thermoplastic UL94-V0
- Actuator : polyamide 12, rubber filled
- Bushing/bezel : polyamide 6/6
- Contacts : solid silver, gold plated
- Terminal seal : epoxy

## ENVIRONMENTAL SPECIFICATIONS

- Front panel sealing (switches mounted on panel) :
  - . IP67 (threaded bushing models)
  - . IP54 (snap-in models)
- Operating temperature : -20°C to +85°C

B1

SERIES	Mounting	Electrical function	Terminals	Contacts	Actuator colours	Case colours
IF	<b>B</b> Snap-in <b>S</b> Threaded bushing	<b>3</b> Normally open (NO)	<b>Z1</b> Quick-connect or solder 2,8 x 0,5 mm	<b>AD</b> Solid silver, gold plated	<b>1</b> Blue <b>5</b> Yellow <b>1/4</b> Dark blue <b>6</b> Red <b>2</b> Black <b>7/1</b> White <b>3</b> Green <b>9</b> Orange Grey RAL7040 : on request	<b>00</b> Black <b>20</b> Red

## Models



Snap-in  
**IFB3Z1AD** NO



Threaded bushing  
**IFS3Z1AD** NO

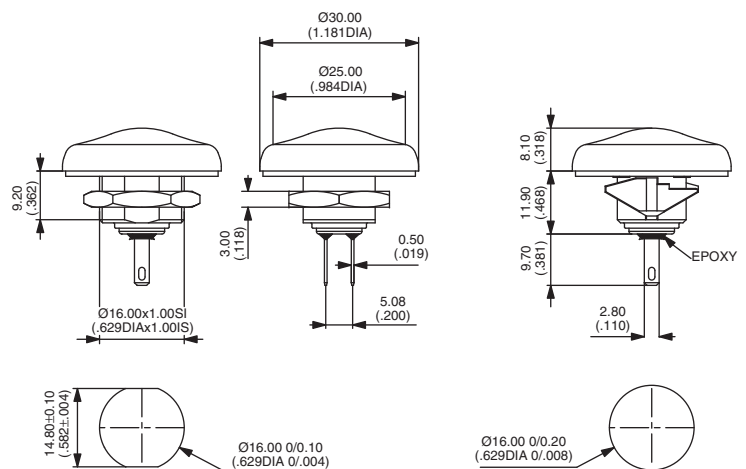

**Mounting accessories** : Standard hardware supplied : 1 flat seal (IFB series)  
1 flat seal and 1 hex nut 19 mm (.748) across flats (IFS series) . The hex nut is presented in section I (part number 10-621).

**Packaging unit** : 20 pieces