

- ⊕ REPRESENTS A CRITICAL DIMENSION.
- MINIMUM PUSHOUT FORCE FOR CONTACTS, WELD TABS AND THREADED INSERTS: 12 OZ.
- MINIMUM LOCKING CLIP RETENTION: 8 OZS.
- MAXIMUM HEIGHT VARIATION BETWEEN ANY TWO PINS: .005[0.13]
- MAXIMUM TERMINAL BURR: .003[0.08]
- COPLANARITY: .004[0.10] = POS 02 THRU 26  
.006[0.15] = POS 27 THRU 50
- MEASURED FROM BEND.
- DIMENSION CHANGED PER REVISION AD. CONTACT ENGINEERING FOR INFORMATION.
- MEASURE FROM TIPS OF PIN.
- THIS FEATURE ONLY PRESENT ON -01 & -02 LEAD STYLES.
- DUE TO THE HIGH AMOUNT OF INSERTION FORCE NEEDED, THE -LC OPTION IS NOT COMPATIBLE WITH AUTO PLACEMENT. SAMTEC RECOMMENDS MANUAL PLACEMENT FOR ALL ASSEMBLIES WITH THE -LC OPTION.
- SIDES OF PLASTIC BODIES ON ALL LEAD STYLES EXCEPT THE -01, -02 & -03 WILL BE SOLID AND WITHOUT SIDE SLOTS.
- VOIDS AT KEYING NOTCH LOCATION MAY BE BLIND AT VENDOR'S DISCRETION FOR -01, -02 & -03 LEAD STYLES.

DO NOT SCALE FROM THIS PRINT

TFM-1XX-XX-XXX-D-XXX

No OF POSITIONS  
LEAD STYLE -01, -02, -03: -02 THRU -50 [ALL POSITIONS AVAILABLE]  
LEAD STYLES -11, -12, -13: (-05 THRU -50 MULTIPLES OF 5) POSITIONS 12, 16, 17 ALSO AVAILABLE  
LEAD STYLES -21, 22, 23: (-05 THRU -50 MULTIPLES OF 5) POSITIONS 12 & 13 ALSO AVAILABLE  
LEAD STYLES 31, 32: 12 POSITION ALSO AVAILABLE

LEAD STYLE

THROUGH HOLE	SURFACE MOUNT
-01, -03 (SEE FIG 1)	-02 (SEE FIG 2)
-11, -13 (SEE FIG 1)	-12 (SEE FIG 2)
-21, -23 (SEE FIG 1)	-22 (SEE FIG 2)
-31 (SEE FIG 1)	-32 (SEE FIG 2)

PLATING SPECIFICATION

- S: 30μ" SELECTIVE GOLD ON CONTACT AREA, MATTE TIN TAIL
- L: 15μ" SELECTIVE GOLD ON CONTACT AREA, MATTE TIN TAIL
- F: 3μ" FLASH GOLD ON CONTACT AREA, MATTE TIN TAIL
- H: 30μ" SELECTIVE GOLD ON CONTACT AREA, 3μ" FLASH GOLD ON TAIL
- SM: 30μ" SELECTIVE GOLD ON CONTACT AREA, MATTE TIN TAIL
- LM: 15μ" SELECTIVE GOLD ON CONTACT AREA, MATTE TIN TAIL
- FM: 3μ" FLASH GOLD ON CONTACT AREA, MATTE TIN TAIL
- STL: 30μ" SELECTIVE GOLD ON CONTACT AREA, TIN/LEAD (90/10 ±5%) TAIL

BODY SPECIFICATION

-D: DOUBLE ROW

OPTION

- A: ALIGNMENT PIN (USE TFM-XX-D-XX-A, SEE TABLE 1) (SEE FIG 8, SHT 3) (NOT AVAILABLE FOR -RA OR -REX)
- LC: LOCKING CLIP (USE LC-05-TM) (NOT AVAILABLE FOR -RA OR -REX) (SEE FIG 10, SHT 3 & NOTES 3 & 11)
- P: PICK AND PLACE PAD (USE PPP-04) (AVAILABLE IN ALL POSITIONS -05 THRU -50 EXCEPT -05 WITH -WT) (NOT AVAILABLE FOR -RA OR -REX, SEE FIG 7, SHT 3)
- RA: RIGHT ANGLE (AVAILABLE ONLY IN LEAD STYLE: -01 SEE FIG 5, SHT 2)
- TR: TAPE AND REEL (SEE FIG 4, SHT 5) (NOT AVAILABLE WITH -DS OPTION)
- SA: STAKED ALIGNMENT PIN (SEE FIG 9, SHT 3) (NOT AVAILABLE FOR -RA OR -RE)
- K: POLYIMIDE FILM (SEE FIG 3, SHT 2) (USE K-DOT-.217-.313-.005) (NOT AVAILABLE FOR -RA OR -REX) (ALL LEAD STYLES EXCEPT -21 AVAILABLE)
- WT: WELD TABS (USE WT-25-XX-T) (AVAILABLE ON -01, -02 & -03 LEAD STYLES ONLY) (SEE FIG 6, SHT 2) (MATES WITH SFSS/SFSD -SR & -DR ONLY) (NOT AVAILABLE WITH -A, -LC, -RA, OR -SA OPTIONS)
- RE1: RIGHT ANGLE ELEVATED .062 PCB (USE TFM-XX-D-01-RE, NOT AVAILABLE WITHOUT -WT, AVAILABLE IN LEAD STYLE -01 ONLY, -03 THRU -50 POS) (MATES WITH SFSS/SFSD -SR & -DR ONLY) (SEE FIG 11, SHT 4)
- RE2: RIGHT ANGLE ELEVATED .093 PCB (USE TFM-XX-D-01-RE, NOT AVAILABLE WITHOUT -WT, AVAILABLE IN LEAD STYLE -01 ONLY, -03 THRU -50 POS) (MATES WITH SFSS/SFSD -SR & -DR ONLY) (SEE FIG 11, SHEET 4)
- SN: SOLDER NAIL FOR .062 BOARD (TFM-XX-D-01-SN AND WT-27-01-T) (SEE FIG12, SHT 3) (ONLY AVAILABLE WITH -02 LEAD STYLE) (NOT AVAILABLE WITH OPTIONS -A, -LC, -RA, -SA, -WT, -RE1 OR -RE2)
- SN2: SOLDER NAIL FOR .093 BOARD (TFM-XX-D-01-SN AND WT-27-02-T) (SEE FIG12, SHT 3) (ONLY AVAILABLE WITH -02 LEAD STYLE) (NOT AVAILABLE WITH OPTIONS -A, -LC, -RA, -SA, -WT, -RE1 OR -RE2)
- DS: DUAL SCREW DOWN FOR .062 BOARD (SEE FIG 18, SHT 5) (ONLY AVAILABLE WITH -01 & -02 LEAD STYLE, 02 THRU 40 POSITIONS) (NOT AVAILABLE WITH OPTIONS -A, -LC, -P, -RA, -TR, -SA, -K, -WT, -RE1, -RE2, -SN, -SN2) (-01 LEAD STYLE USES TFM-XX-D-01-DSL & T1-M2-4-VSFM-T, 02 LEAD STYLE USES TFM-XX-D-01-DSA & T1-M2-4-VSFM-T)

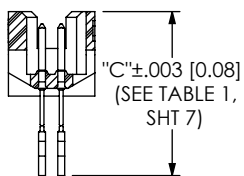
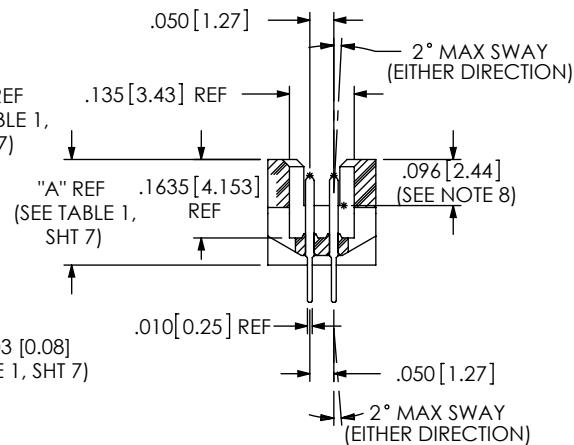
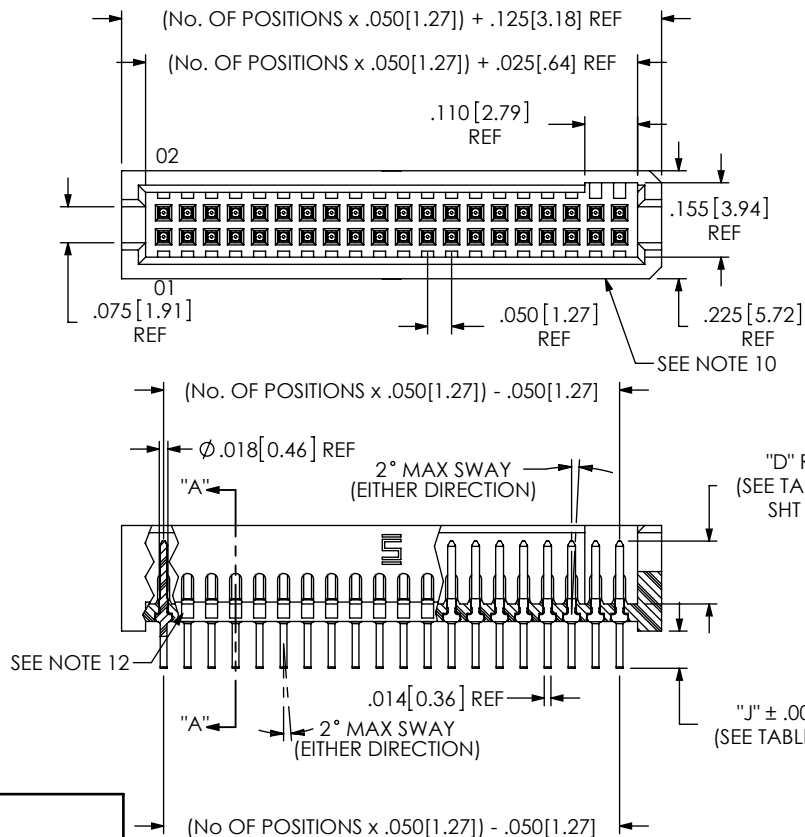

FIG 1 THROUGH HOLE -01, -03, -11, -13, -21, -23, -31

IN-PROCESS

UNLESS OTHERWISE SPECIFIED, DIMENSIONS ARE IN INCHES. TOLERANCES ARE:  
DECIMALS ANGLES  
.XX: ±.01 [.3] 2°  
.XXX: ±.005 [.13]  
.XXXX: ±.0020 [.051]

PROPRIETARY NOTE  
THIS DOCUMENT CONTAINS INFORMATION CONFIDENTIAL AND PROPRIETARY TO SAMTEC, INC. AND SHALL NOT BE REPRODUCED OR TRANSFERRED TO OTHER DOCUMENTS OR DISCLOSED TO OTHERS OR USED FOR ANY PURPOSE OTHER THAN THAT WHICH IT WAS OBTAINED WITHOUT THE EXPRESSED WRITTEN CONSENT OF SAMTEC, INC.



520 PARK EAST BLVD, NEW ALBANY, IN 47150  
PHONE: 812-944-6733 FAX: 812-948-5047  
e-Mail: info@SAMTEC.com code 55322

MATERIAL: DO NOT SCALE DRAWING SHEET SCALE: 2.5:1  
INSULATOR: LCP, UL 94-VO COLOR: BLACK  
TERMINAL: PHOSPHOR BRONZE

DESCRIPTION: .050 X .050 TERMINAL STRIP  
DWG. NO. TFM-1XX-XX-XXX-D-XXX  
BY: B RAY 7-10-2007 SHEET 1 OF 7

REVISION ET

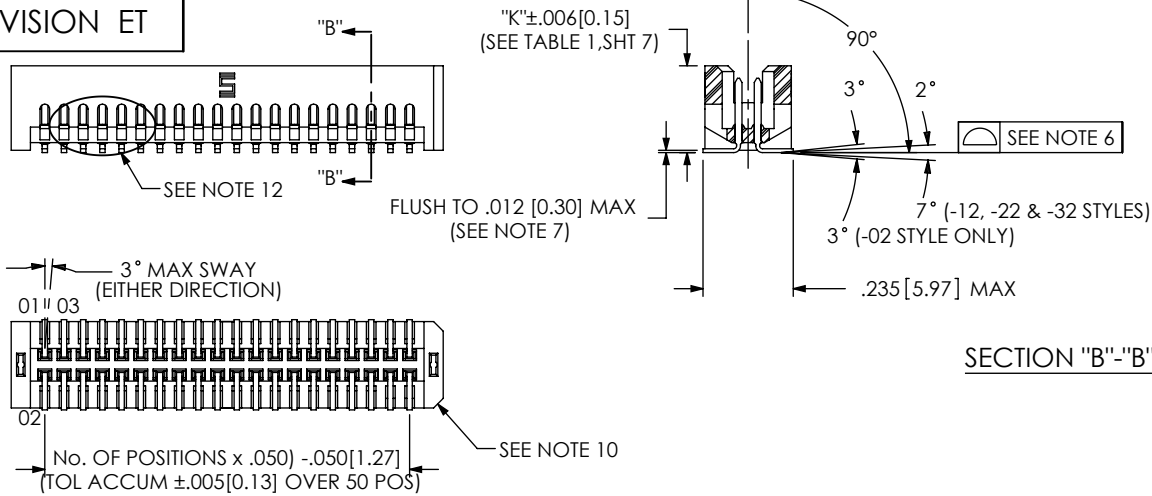
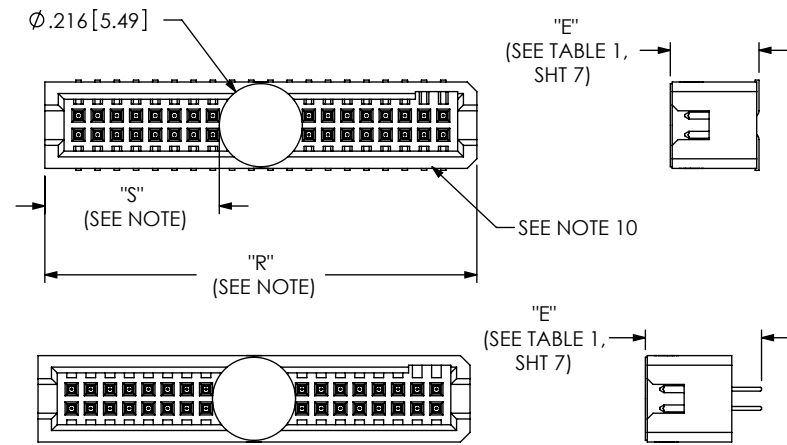

FIG 2  
SURFACE MOUNT  
-02, -12, -22, -32  
DIFFERENT AS SHOWN, OTHERWISE SAME AS FIG 1



NOTE: "R" = OVERALL LENGTH (REF)  
"S" = {"R" - .216 [5.49] / 2} ±.020 [0.51]

FIG 3  
-K: POLYIMIDE FILM PAD

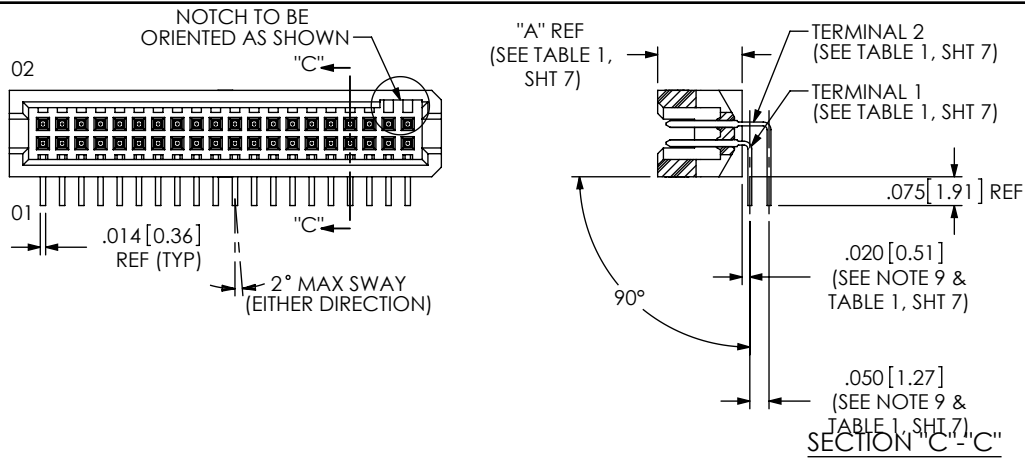

FIG 5  
-RA OPTION  
DIFFERENT AS SHOWN, OTHERWISE SAME AS FIG 1

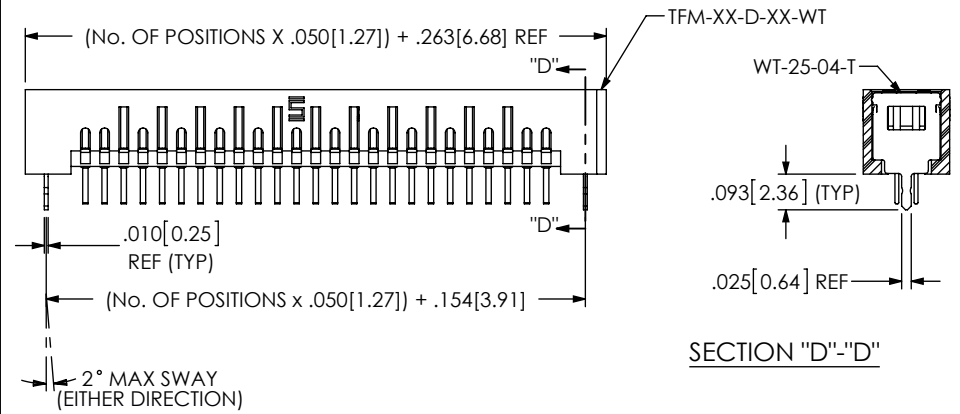
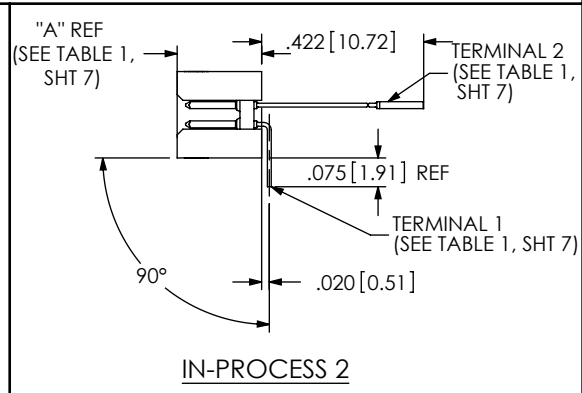
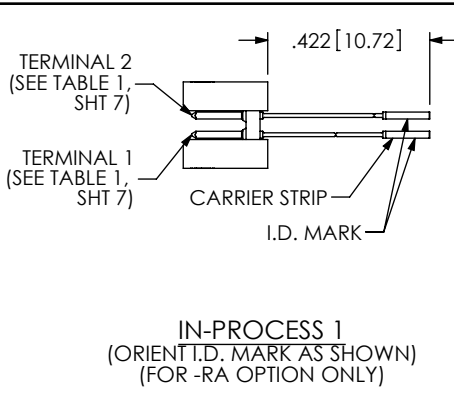
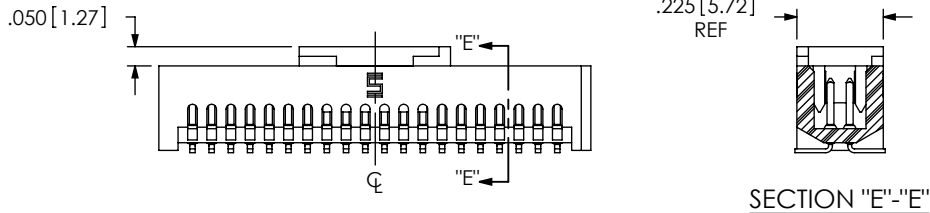
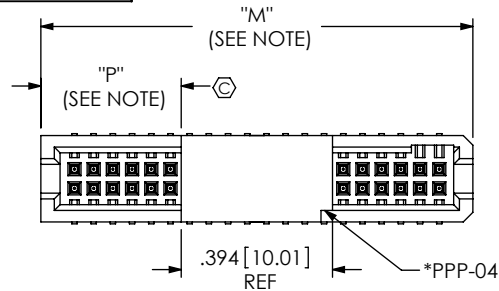

FIG 6  
-WT OPTION  
DIFFERENT AS SHOWN, OTHERWISE SAME AS FIG 1

F:\DWG\MISC\MKTG\TFM-1XX-XX-XXX-D-XXX-MKT.SLDDRW



<p>PROPRIETARY NOTE</p> <p>THIS DOCUMENT CONTAINS INFORMATION CONFIDENTIAL AND PROPRIETARY TO SAMTEC, INC. AND SHALL NOT BE REPRODUCED OR TRANSFERRED TO OTHER DOCUMENTS OR DISCLOSED TO OTHERS OR USED FOR ANY PURPOSE OTHER THAN THAT WHICH IT WAS OBTAINED WITHOUT THE EXPRESSED WRITTEN CONSENT OF SAMTEC, INC.</p> <p>DO NOT SCALE DRAWING</p> <p>SHEET SCALE: 2:1</p>	<p>520 PARK EAST BLVD., NEW ALBANY, IN 47150 PHONE: 812-944-6733 FAX: 812-948-5047 e-Mail: info@SAMTEC.com code 55322</p>	
	<p>DESCRIPTION:</p> <p>.050 X .050 TERMINAL STRIP</p>	
	<p>DWG. NO.</p> <p>TFM-1XX-XX-XXX-D-XXX</p>	
	<p>BY: B RAY</p>	<p>7-10-2007</p>



NOTE: "M" = (No. OF POSITIONS X .050[1.27]) + .125[3.18] (REF)  
 WITH -WT "M" = (No. OF POSITIONS X .050[1.27]) + .263[6.68] (REF)  
 "P" = {("M" - .394[10.01]) / 2} ±.020[.51]

\* NOTCH ON PAD TO BE ON SAME END AS THE NOTCH IN THE TFM BODY

FIG 7  
 -P OPTION  
 DIFFERENT AS SHOWN, OTHERWISE SAME AS FIG 1  
 (PAD TO BE POSITIONED ON C.L. AS SHOWN)

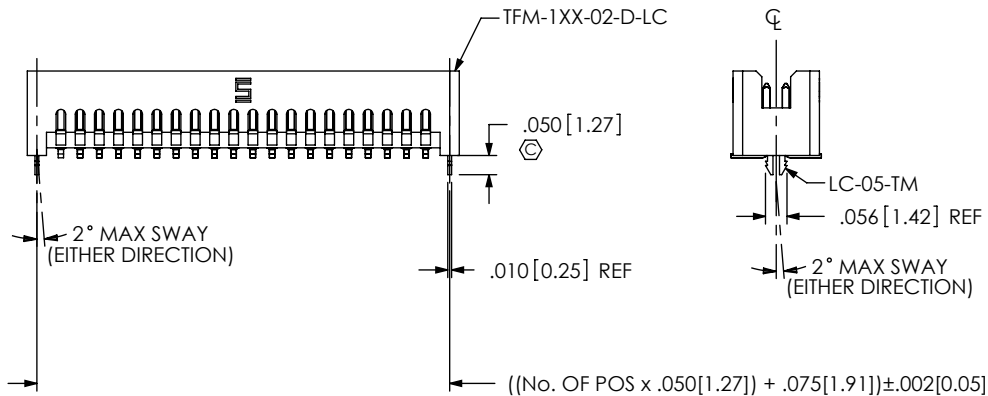

FIG 10  
 -LC OPTION  
 DIFFERENT AS SHOWN, OTHERWISE SAME AS FIG 1  
 (NOT AVAILBLE ON -RA)

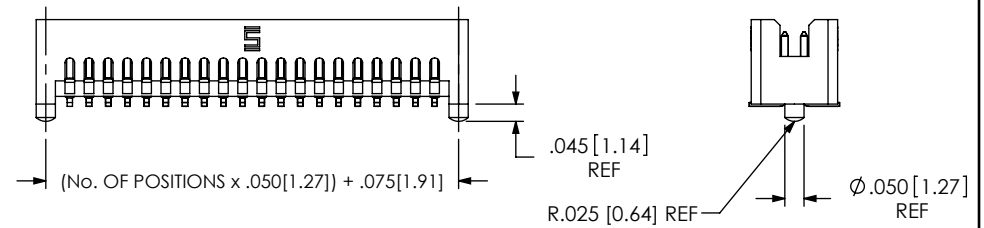

FIG 8  
 -A OPTION  
 DIFFERENT AS SHOWN, OTHERWISE SAME AS FIG 1

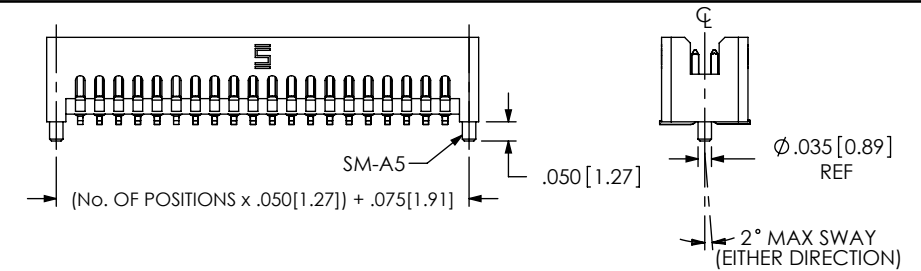

FIG 9  
 -SA OPTION: STAKED ALIGNMENT PIN  
 DIFFERENT AS SHOWN, OTHERWISE SAME AS FIG 1

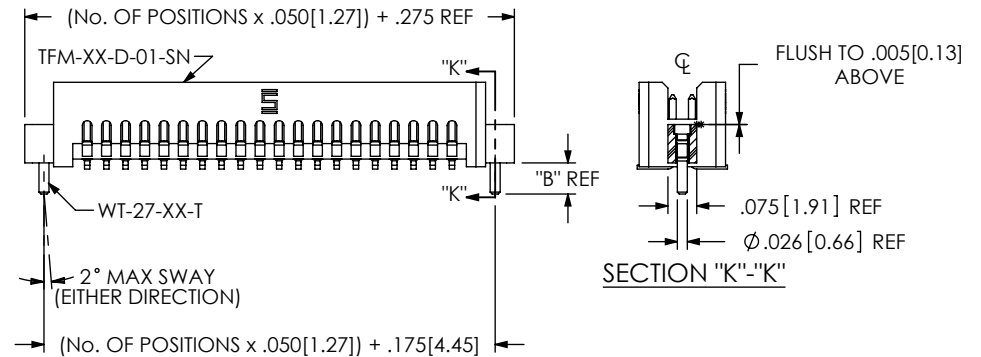

FIGURE 12  
 -SNX: SOLDER NAIL  
 DIFFERENT AS SHOWN, OTHERWISE SAME AS FIG 1

TABLE 4	
OPTION	"B"
-SN	.081 2.06
-SN2	.115 2.92

F:\DWG\MISC\MKTG\TFM-1XX-XX-XXX-D-XXX-MKT.SLDDRW

PROPRIETARY NOTE  
 THIS DOCUMENT CONTAINS INFORMATION CONFIDENTIAL AND PROPRIETARY TO SAMTEC, INC. AND SHALL NOT BE REPRODUCED OR TRANSFERRED TO OTHER DOCUMENTS OR DISCLOSED TO OTHERS OR USED FOR ANY PURPOSE OTHER THAN THAT WHICH IT WAS OBTAINED WITHOUT THE EXPRESSED WRITTEN CONSENT OF SAMTEC, INC.

DO NOT SCALE DRAWING

SHEET SCALE: 2:1

**samtec**

520 PARK EAST BLVD, NEW ALBANY, IN 47150  
 PHONE: 812-944-6733 FAX: 812-948-5047  
 e-Mail: info@SAMTEC.com code 55322

DESCRIPTION:  
 .050 X .050 TERMINAL STRIP

DWG. NO.  
**TFM-1XX-XX-XXX-D-XXX**

BY: B RAY 7-10-2007 SHEET 3 OF 7

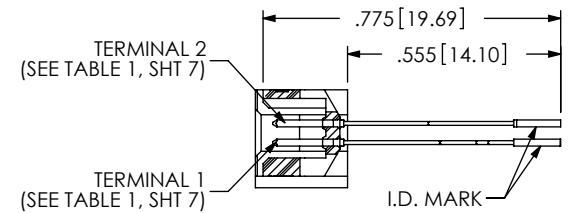
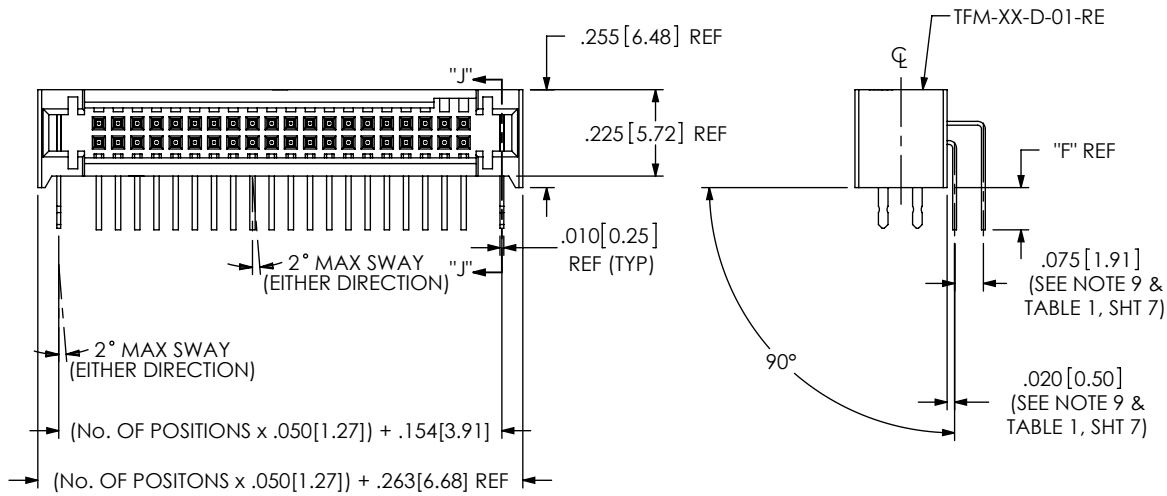
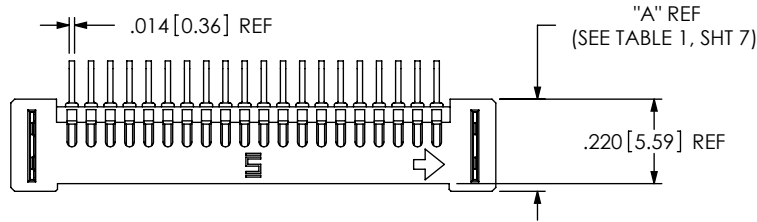

IN-PROCESS 1  
(ORIENT I.D. MARK AS SHOWN)  
(FOR -RA OPTION ONLY)

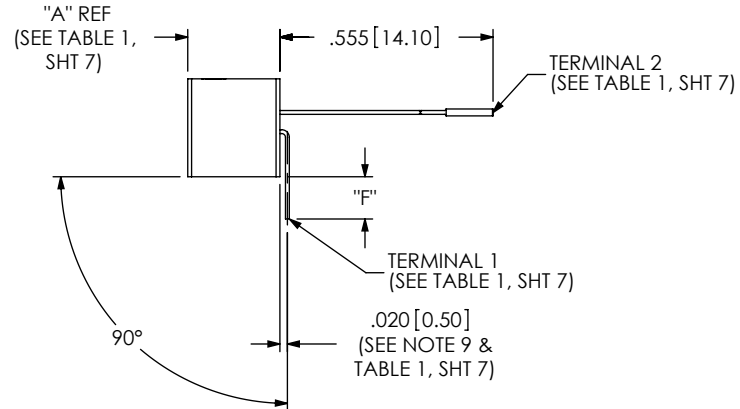

IN-PROCESS 2

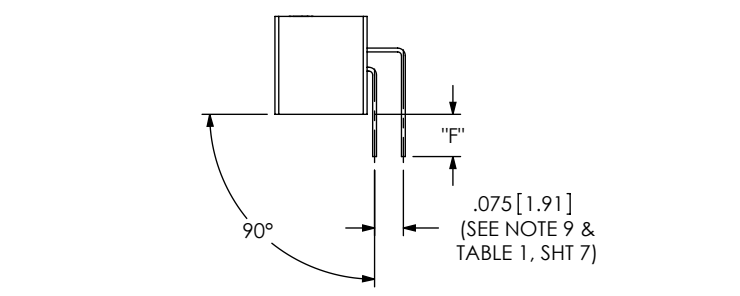

IN-PROCESS 3

F:\DWG\MISC\MKTG\TFM-1XX-XX-XXX-D-XXX-MKT.SLDDRW

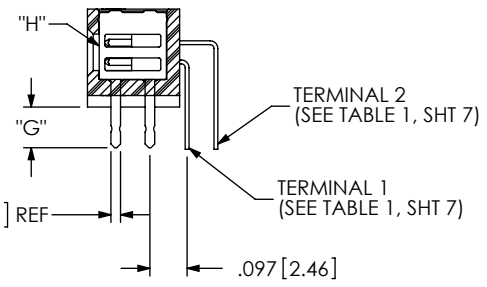

SECTION "J"-"J"

TABLE 3			
LEAD STYLE	"F"	"G"	"H"
-01-RE1	.078 [1.98]	.074 [1.88]	WT-81-01-T
-01-RE2	.110 [2.79]	.106 [2.69]	WT-81-02-T

FIG 11  
-REX: RIGHT ANGLE ELEVATED  
TFM-120-XX-XXX-D-RE2 SHOWN  
DIFFERENT AS SHOWN, OTHERWISE SAME AS FIG 1

PROPRIETARY NOTE  
THIS DOCUMENT CONTAINS INFORMATION  
CONFIDENTIAL AND PROPRIETARY TO  
SAMTEC, INC. AND SHALL NOT BE REPRODUCED OR  
DISCLOSED TO OTHERS OR USED FOR ANY  
PURPOSE OTHER THAN THAT WHICH IT WAS  
OBTAINED WITHOUT THE EXPRESSED WRITTEN  
CONSENT OF SAMTEC, INC.



DO NOT SCALE DRAWING

SHEET SCALE: 2:1

DESCRIPTION:  
.050 X .050 TERMINAL STRIP  
DWG. NO.  
TFM-1XX-XX-XXX-D-XXX  
BY: B RAY 7-10-2007 SHEET 4 OF 7

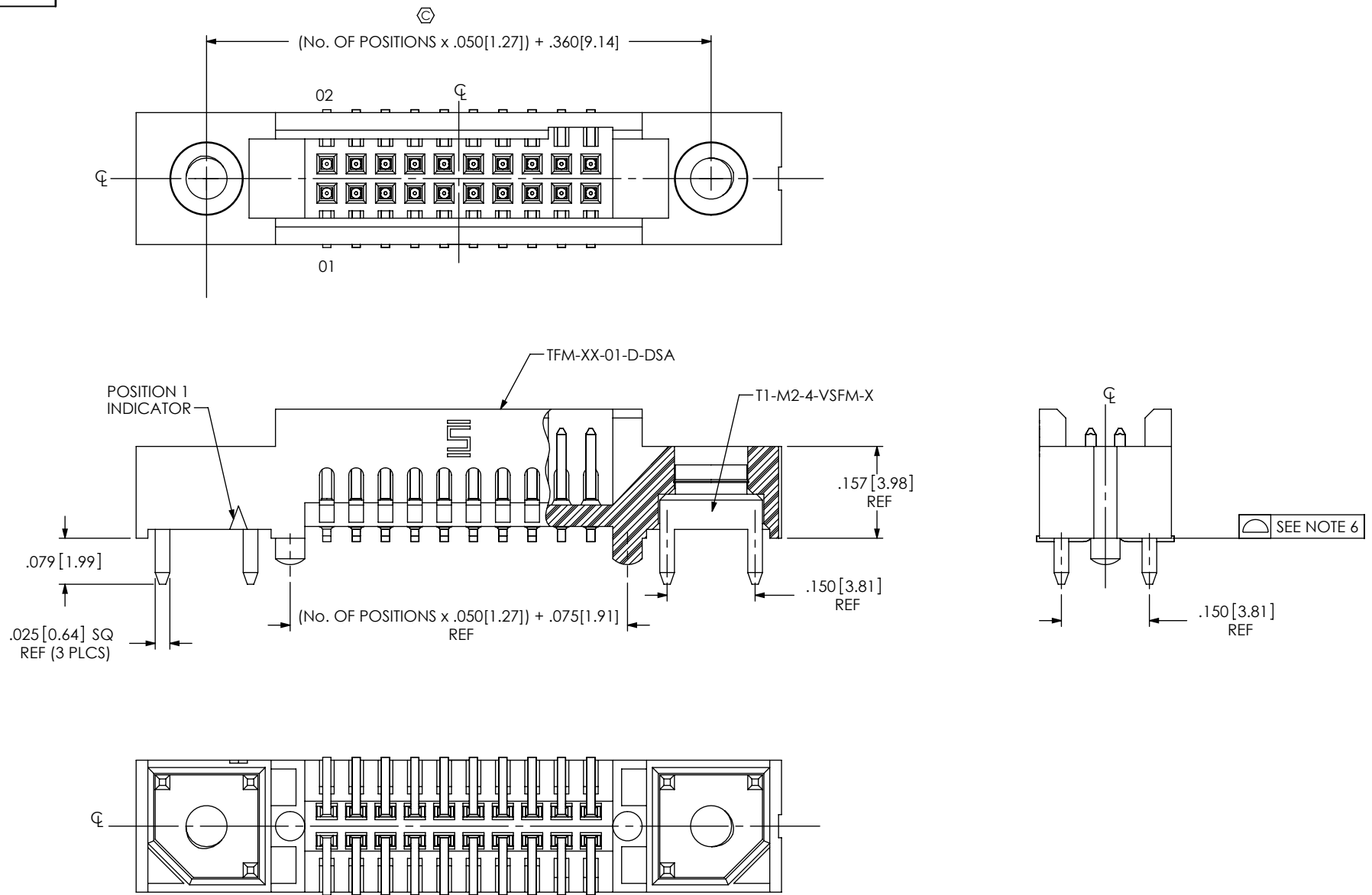



FIG 18  
 -DS: DUAL SCREW DOWN  
 TFM-110-02-XXX-D-DS SHOWN  
 DIFFERENT AS SHOWN, OTHERWISE SAME AS FIG 1

F:\DWG\MISC\MKTG\TFM-1XX-XX-XXX-D-XXX-MKT.SLDDRW

<p>PROPRIETARY NOTE</p> <p>THIS DOCUMENT CONTAINS INFORMATION CONFIDENTIAL AND PROPRIETARY TO SAMTEC, INC. AND SHALL NOT BE REPRODUCED OR TRANSFERRED TO OTHER DOCUMENTS OR DISCLOSED TO OTHERS OR USED FOR ANY PURPOSE OTHER THAN THAT WHICH IT WAS OBTAINED WITHOUT THE EXPRESSED WRITTEN CONSENT OF SAMTEC, INC.</p> <p>DO NOT SCALE DRAWING</p> <p>SHEET SCALE: 2:1</p>		
	<p>520 PARK EAST BLVD, NEW ALBANY, IN 47150                  PHONE: 812-944-6733 FAX: 812-948-5047                  e-Mail info@SAMTEC.com code 55322</p>	
	<p>DESCRIPTION:                  .050 X .050 TERMINAL STRIP</p>	
	<p>DWG. NO.                  TFM-1XX-XX-XXX-D-XXX</p>	<p>BY: B RAY</p>
		<p>SHEET 5 OF 7</p>