

DO NOT SCALE FROM THIS PRINT

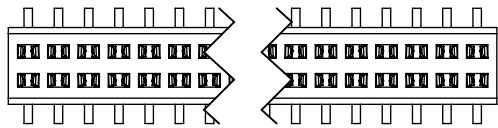

FIG 2
(SAME AS FIG 1 EXCEPT INSULATOR)

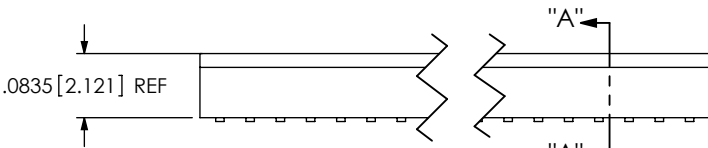
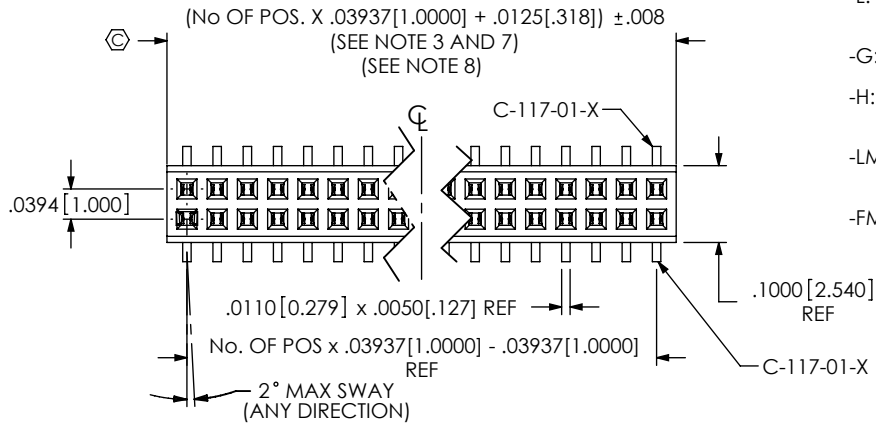

FIG 1

CLM-1XX-XX-XX-D-XX

No OF POSITIONS / ROW
-02 THRU -50

LEAD STYLE SPEC
-02: SURFACE MOUNT
(USE C-117-01-X)

PLATING SPECIFICATION

- F: 3μ" FLASH SELECTIVE GOLD IN CONTACT AREA MATTE TIN ON TAIL (PRE-PLATED CONTACT)
- L: 10μ" LIGHT SELECTIVE GOLD IN CONTACT AREA MATTE TIN ON TAIL (PRE-PLATED CONTACT)
- G: 10μ" GOLD IN CONTACT AREA 3μ" ON TAIL (POST-PLATED CONTACT)
- H: 30μ" HEAVY GOLD IN CONTACT AREA 3μ" ON TAIL (POST-PLATED CONTACT)
- LM: 10μ" LIGHT SELECTIVE GOLD IN CONTACT AREA MATTE TIN ON TAIL (PRE-PLATED CONTACT)
- FM: 3μ" FLASH SELECTIVE GOLD IN CONTACT AREA MATTE TIN ON TAIL (PRE-PLATED CONTACT)

OPTION

- P: PICK & PLACE PAD (AVAILABLE ON POS 7 THRU 50 ONLY) (SEE FIG 3, SHT 2)(USE LMP-04)
- TR: TAPE & REEL
- BE: BOTTOM ENTRY ONLY (SEE FIG 2)(USE CLM-XX-DBE-XX)
- PA: PICK & PLACE PAD W/ ALIGNMENT PINS (SEE FIG 4, SHT 2)
- A: ALIGNMENT PIN (USE CLM-XX-D-XX) (AVAILABLE ON POS 3 THRU 50 ONLY) (SEE FIG 5, SHT 2)
- K: POLYIMIDE FILM PAD (AVAILABLE ON POS 7 THRU 50 ONLY) (.005 [.13] THICKNESS)(SEE FIG 6, SHT 2) (USE K-DOT-.138-.250-.005)

BODY SPEC

- D: DOUBLE ROW (USE CLM-XX-D)

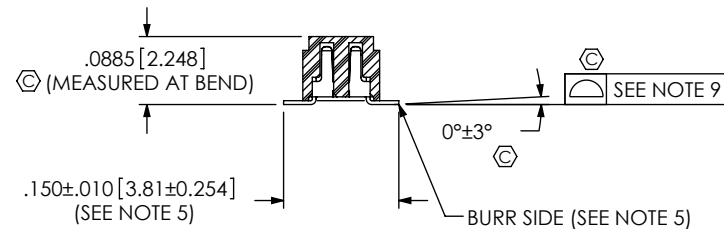
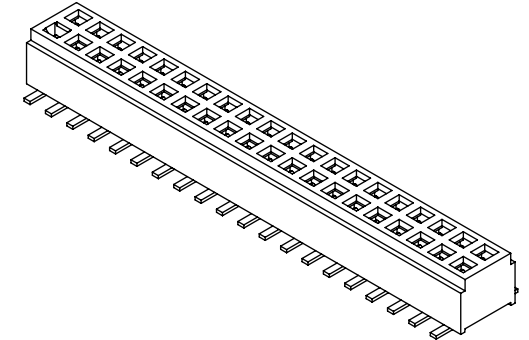

SECTION "A"- "A"
SCALE 4 : 1

NOTES:

1. Ⓢ REPRESENTS CRITICAL DIMENSION.
2. MINIMUM PUSHOUT FORCE: .5 LB.
3. WILL LOSE A POSITION FOR EVERY CUT MADE ON A SOCKET STRIP.
4. POSITIONS -05 THROUGH -50 ARE TO BE TUBED. POSITIONS -02 THRU -04 TO BE LAYER PACKAGED ONLY.
5. SHEAR TAILS TO DIMENSIONS SHOWN, .003 MAX SHEAR BURR.
6. PARTS TO BE SYMMETRICAL ABOUT Q.
7. CUT FLASH TO BE .010 [.25] MAX WITH NO FLASH ALLOWED IN HOLES OR EXTENDING BELOW LEADS.
8. ENDWALL AFTER CUTTING: .0155±.0025 [.398±.064]
9. COPLANARITY TO BE .0040 FOR POSITIONS 2-25 & .0060 FOR POSITIONS 26-50.

UNLESS OTHERWISE SPECIFIED, DIMENSIONS ARE IN INCHES.
TOLERANCES ARE:
DECIMALS ANGLES
.XX: ±.01 [.3] 2°
.XXX: ±.005 [.13]
.XXXX: ±.0020 [.051]

PROPRIETARY NOTE
THIS DOCUMENT CONTAINS INFORMATION CONFIDENTIAL AND PROPRIETARY TO SAMTEC, INC. AND SHALL NOT BE REPRODUCED OR TRANSFERRED TO OTHER DOCUMENTS OR DISCLOSED TO OTHERS OR USED FOR ANY PURPOSE OTHER THAN THAT WHICH IT WAS OBTAINED WITHOUT THE EXPRESSED WRITTEN CONSENT OF SAMTEC, INC.



520 PARK EAST BLVD, NEW ALBANY, IN 47150
PHONE: 812-944-6733 FAX: 812-948-5047
e-Mail: info@SAMTEC.com code 55322

MATERIAL: DO NOT SCALE DRAWING SHEET SCALE: 2:1
BODY: LCP, UL 94 VO
COLOR: BLACK
TERMINAL:
PHOS BRONZE
F:\DWG\MISC\MKTG\CLM-1XX-XX-XX-D-XX-MKT.SLDDRW

DESCRIPTION:
LOW PROFILE 1MM x 1MM DOUBLE ROW BODY
DWG. NO.
CLM-1XX-XX-XX-D-XX
BY: G. PURVIS 08/10/94 SHEET 1 OF 2

FIG 3
-P: PICK & PLACE PAD
AVAILABLE ON POSITIONS 7 THRU 50 ONLY

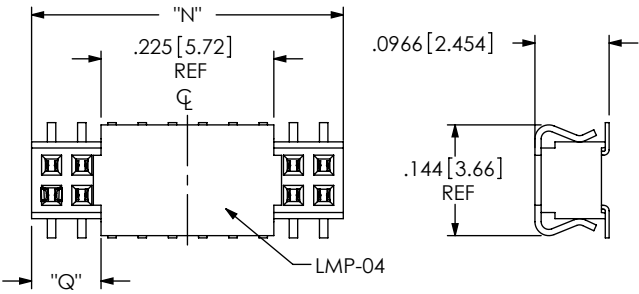

NOTE: "N" = USED MEASURED DIMENSION (REF)
"Q" = $\{("N" - .225[5.72]) / 2\} \pm .020[.51]$

FIG 5
-A: MOLDED ALIGNMENT PIN

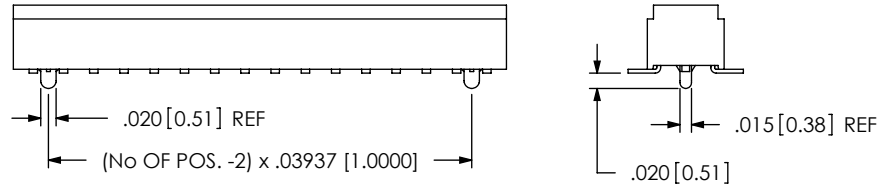

-PACKAGING
(SEE NOTE 4)

TABLE 2
(INCLUDES -D & -D-BE)

OPTION	TUBE	PLUG
-P, -A-P	PT-CLX001-D	TP-33
-PA	PT-CLP001-PA	TP-09
-NONE -A, -A-K, -K	PT-1-24-01-50	TP-33

FIG 4
-PA: PICK & PLACE PAD WITH ALIGNMENT PINS

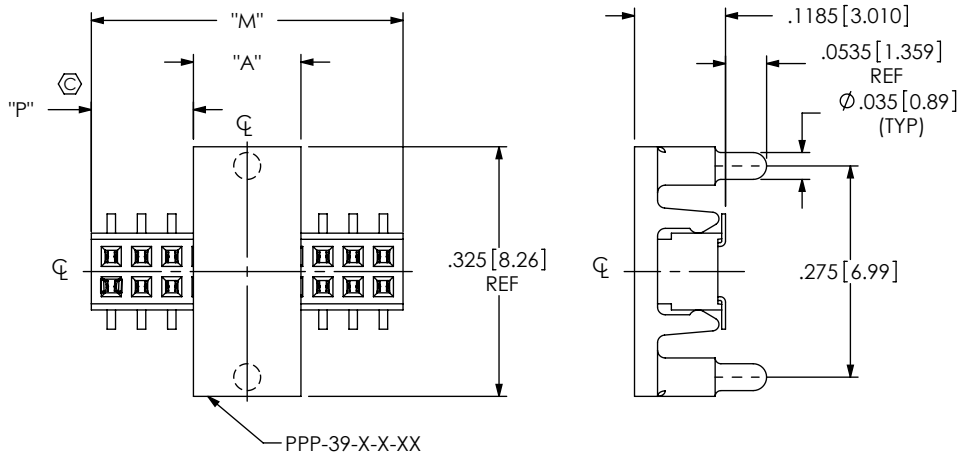

POS / ROW	"A"	"M"	"P"
4-15	.140[3.58] REF	USED MEASURED DIMENSION(REF)	$\{("M" - "A") / 2\} \pm .010[.25]$
16-50	.280[7.11] REF		

POSITIONS		PAD
EVEN	4-14	PPP-39-E-4-15
	16-50	PPP-39-E-16-50
ODD	5-15	PPP-39-O-4-15
	17-49	PPP-39-O-16-50

FIG 6
-K: POLYAMIDE FILM PAD
AVAILABLE ON POSITIONS 7 THRU 50 ONLY

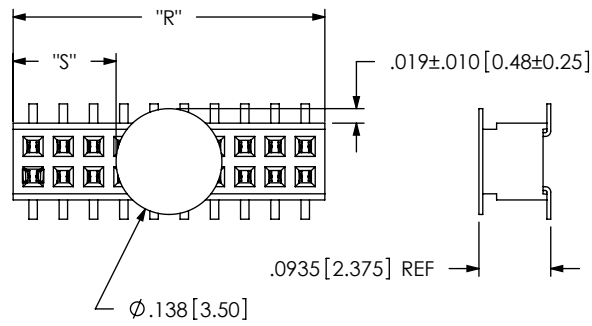

NOTE: "R" = USED MEASURED DIMENSION (REF)
"S" = $\{("R" - .138[3.50]) / 2\} \pm .020[.51]$

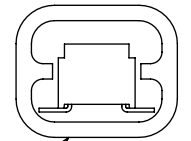
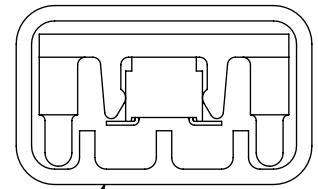
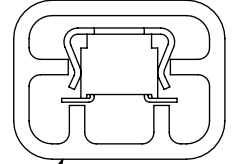

PROPRIETARY NOTE
THIS DOCUMENT CONTAINS INFORMATION CONFIDENTIAL AND PROPRIETARY TO SAMTEC, INC. AND SHALL NOT BE REPRODUCED OR TRANSFERRED TO OTHER DOCUMENTS OR DISCLOSED TO OTHERS OR USED FOR ANY PURPOSE OTHER THAN THAT WHICH IT WAS OBTAINED WITHOUT THE EXPRESSED WRITTEN CONSENT OF SAMTEC, INC.

DO NOT SCALE DRAWING

SHEET SCALE: 4:1



520 PARK EAST BLVD, NEW ALBANY, IN 47150
PHONE: 812-944-6733 FAX: 812-948-5047
e-Mail info@SAMTEC.com code 55322

DESCRIPTION:
LOW PROFILE 1MM x 1MM DOUBLE ROW BODY

DWG. NO. **CLM-1XX-XX-XX-D-XX**

BY: G. PURVIS 08/10/94 SHEET 2 OF 2