

REVISION AF

DO NOT SCALE FROM THIS PRINT

DESIGNED & DIMENSIONED IN MILLIMETERS [INCHES]

ERF8-XXX-XX.X-X-DV-XXXX-TR

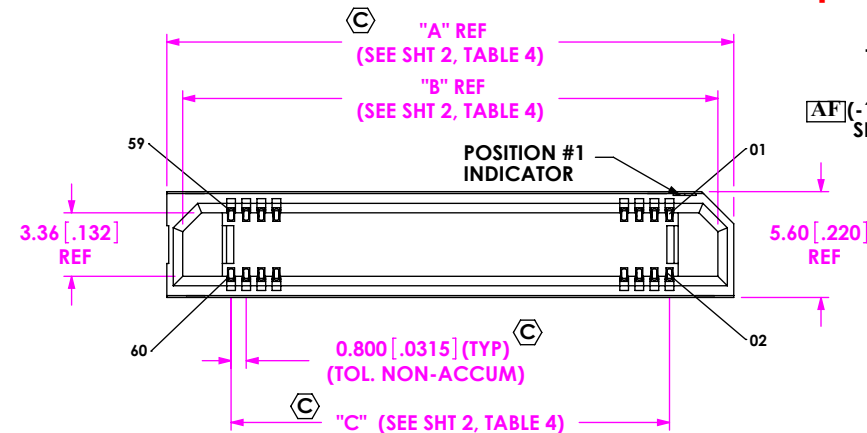

No OF POSITIONS (PER ROW)
 -005, -010, -011, -013, -020, -023, -025, -030, -035, -040, -049, -050, -060, -070, -075, -100
[AF] (-100 POSITION AVAILABLE IN -05.0 ONLY SEE NOTE 9)

TAPE & REEL (STANDARD PACKAGING) (NOT AVAILABLE IN 100 POS) (SEE NOTE 4 & 7)

LEAD STYLE
 -05.0 = 5mm
 -07.0 = 7mm
 **-10.0 = 10mm

PLATING SPECIFICATION
 -L: 10µ" SELECTIVE GOLD IN CONTACT AREA, MATTE TIN ON TAIL (USE C-211-XX.X-L)
 -S: 30µ" SELECTIVE GOLD IN CONTACT AREA, MATTE TIN ON TAIL (USE C-211-XX.X-S)

OPTION
 -K: POLYIMIDE FILM PAD (SEE FIG 2)
 -L: LATCHES (-05.0 LEAD STYLE ONLY, SEE NOTE 5, SEE FIG 5)
 -EGP: EXTENDED GUIDE POST (SEE NOTE 6, SEE FIG 3)
 -EGPS: EXTENDED GUIDE POST SHIELD (ONLY AVAILABLE IN ***-10.0 LEAD STYLE AND ONLY -10, -20, -25 & -30 POSITIONS SEE FIG 6)
 *** -L2: LATCH WITH LONG WELD TAB (-05.0 & -07.0 LEAD STYLE ONLY, SEE FIG 5)
 *** -E: EXTENDED GUIDE POST WITH LONG WELD TAB, SEE FIG 3
 *** -W: WELD TAB (-05.0 & -07.0 LEAD STYLE ONLY, SEE FIG 10)

ROW SPECIFICATION
 -DV: DOUBLE VERTICAL

** = NOT TOOLED
 *** = NOT RELEASED FOR PRODUCTION

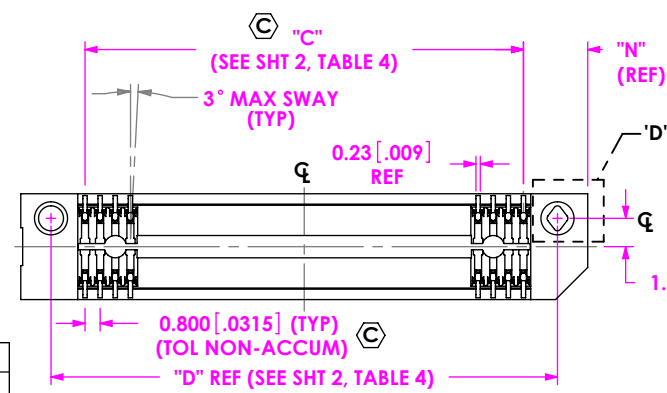
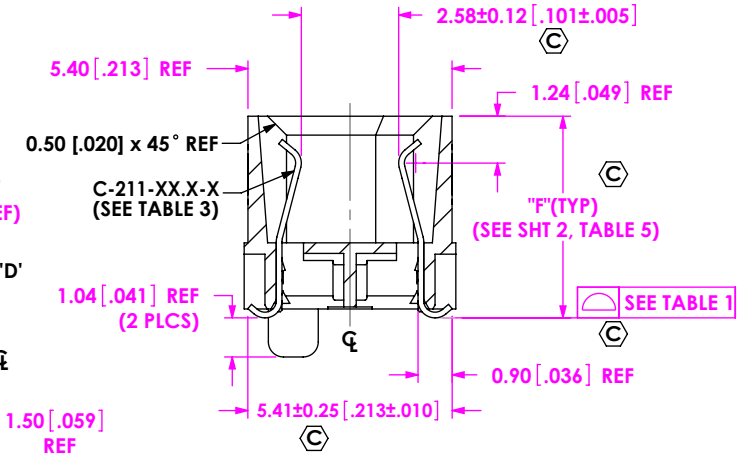
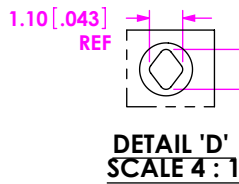
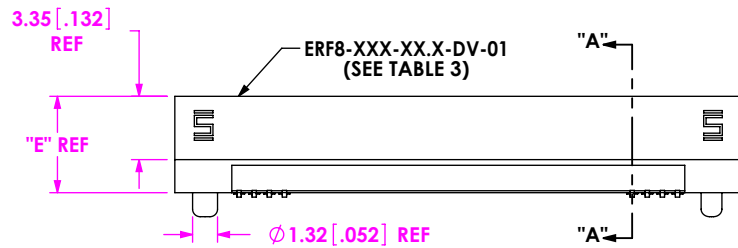

No. OF POS.	
-005, -010, -011, -013, -020, -025, -023 -030	0.10 [.004]
-035, -040, -049, -050, -060	0.12 [.005]
-070, -075, -100	0.15 [.006]

ERF8 LEAD STYLE	ERM8 LEAD STYLE				
	-02.0	-05.0	-08.0	-09.0	** -15.0
-05.0	7.0MM	10.0MM	13.0MM	14.0MM	20.0MM
-07.0	9.0MM	12.0MM	15.0MM	16.0MM	22.0MM
** -10.0	12.0MM	15.0MM	18.0MM	19.0MM	25.0MM

FIG 1 (ERF8-030-05.0-X-DV-XX SHOWN) (CENTER FEATURES REMOVED FOR CLARITY)

OPTION	"N"
NONE	3.40 [.134]
-W, -L, -L2, EGP	4.15 [.163]

- (** = NOT TOOLED)
- NOTES:**
- ⊗ REPRESENTS A CRITICAL DIMENSION.
 - BURR ALLOWANCE: 0.038[.0015] MAX.
 - MINIMUM PUSHOUT FORCE: 2.22 N [.5 LB.]
 - FOR QUANTITIES UP TO 49 PIECES, NO LEADER, TRAILER, OR EIA-481-D REEL WILL BE SUPPLIED. FOR QUANTITIES OF 50-124 PIECES, NO LEADER, TRAILER WILL BE SUPPLIED.
 - NOT AVAILABLE WITH -EGP, -E, -W, -L2 OR -EGPS OPTIONS.
 - OPTION ONLY AVAILABLE ON -07.0 LEAD STYLE.
 - TR PACKAGING NOT AVAILABLE ON 100 POSITION ONLY AVAILABLE IN TRAYS.
 - NOTE DELETED.
 - NOT AVAILABLE WITH -L, -L2, -E, OR -W OPTIONS.

UNLESS OTHERWISE SPECIFIED, DIMENSIONS ARE IN MILLIMETERS [INCHES]. TOLERANCES ARE: DECIMALS ANGLES X.X: ±0.3 [.01] 2° X.XX: ±0.13 [.005] X.XXX: ±0.050 [.0020]	PROPRIETARY NOTE THIS DOCUMENT CONTAINS INFORMATION CONFIDENTIAL AND PROPRIETARY TO SAMTEC, INC. AND SHALL NOT BE REPRODUCED OR TRANSFERRED TO OTHER DOCUMENTS OR DISCLOSED TO OTHERS OR USED FOR ANY PURPOSE OTHER THAN THAT WHICH IT WAS OBTAINED WITHOUT THE EXPRESSED WRITTEN CONSENT OF SAMTEC, INC.	520 PARK EAST BLVD, NEW ALBANY, IN 47150 PHONE: 812-944-6733 FAX: 812-948-5047 e-Mail info@SAMTEC.com code 55322

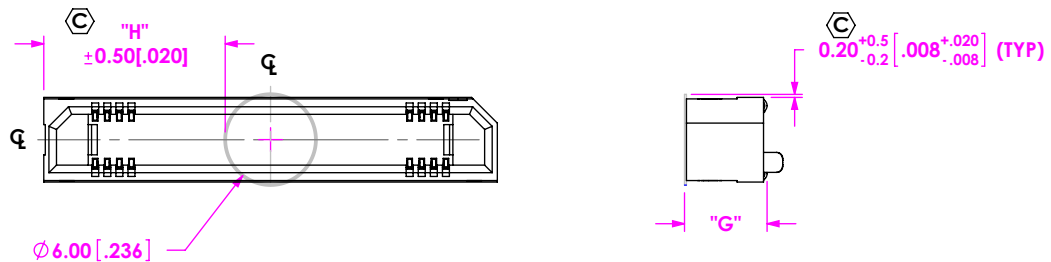
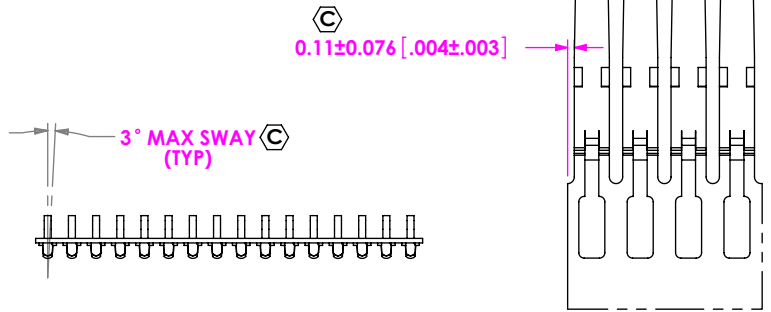

FIG 2
-K OPTION
(USE K-500-300)
(ERF8-030-XX.X-X-DV-K SHOWN)



C-211-XX.X-X IN-PROCESS VIEW

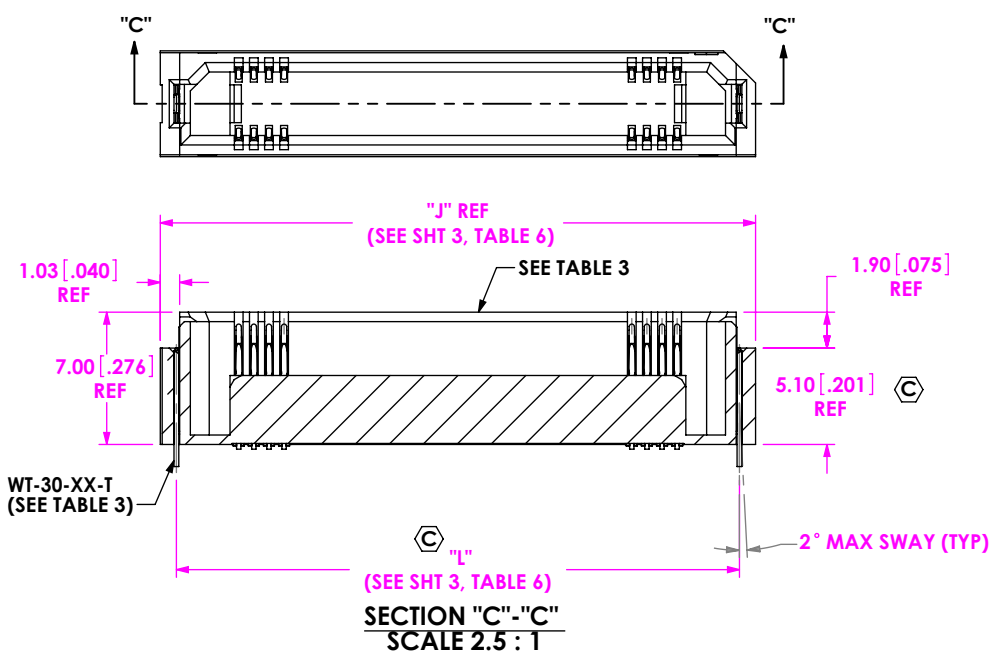

FIG 3
-E AND -EGP OPTION
(ERF8-030-07.0-X-DV-EGP SHOWN)
(SAME AS FIG 1, EXCEPT AS SHOWN)
(AVAILABLE ON -07.0 LEAD STYLE ONLY)
(CENTER FEATURES REMOVED FOR CLARITY)

TABLE 4

POSITION	"A"	"B"	"C"	"D"	"H"
-005	10.00 [.394]	8.32 [.328]	3.200 [.1260]	6.80 [.268]	2.00 [.079]
-010	14.00 [.551]	12.32 [.485]	7.200 [.2835]	10.80 [.425]	4.00 [.157]
-011	14.80 [.583]	13.12 [.517]	8.000 [.3150]	11.60 [.457]	4.40 [.173]
-013	16.40 [.646]	14.72 [.580]	9.600 [.3780]	13.20 [.520]	5.20 [.205]
-020	22.00 [.866]	20.32 [.800]	15.200 [.5984]	18.80 [.740]	8.00 [.315]
-023	24.40 [.961]	22.72 [.894]	17.600 [.6929]	21.20 [.835]	10.40 [.409]
-025	26.00 [1.024]	24.32 [.957]	19.200 [.7559]	22.80 [.898]	10.00 [.394]
-030	30.00 [1.181]	28.32 [1.115]	23.200 [.9134]	26.80 [1.055]	12.00 [.472]
-035	34.00 [1.339]	32.32 [1.272]	27.200 [1.0708]	30.80 [1.213]	14.00 [.551]
-040	38.00 [1.496]	36.32 [1.423]	31.200 [1.2283]	34.80 [1.370]	16.00 [.630]
-049	45.20 [1.780]	43.52 [1.713]	38.400 [1.5118]	42.00 [1.654]	19.60 [.772]
-050	46.00 [1.811]	44.32 [1.745]	39.200 [1.5433]	42.80 [1.685]	20.00 [.787]
-060	54.00 [2.126]	52.32 [2.060]	47.200 [1.8583]	50.80 [2.000]	24.00 [.945]
-070	62.00 [2.441]	60.32 [2.375]	55.200 [2.1732]	58.80 [2.315]	28.00 [1.102]
-075	66.00 [2.598]	64.32 [2.532]	59.200 [2.3307]	62.80 [2.472]	30.00 [1.181]
-100	86.00 [3.386]	84.32 [3.320]	79.200 [3.1181]	82.80 [3.260]	40.00 [1.575]

TABLE 5

HEIGHT	"E"	"F"	"G"
-05.0	5.10 [.201]	5.335 [.2100]	5.52 [.217]
-07.0	7.00 [.275]	7.250 [.2854]	7.37 [.290]
** -10.0	10.10 [.398]	10.335 [.4069]	10.52 [.414]

(** = NOT TOOLED)

TABLE 3

OPTION	STYLE	ERF8-XXX-XX.X-DV-XX	C-211-XX.X-X	WT-30-01-F	"T"	"U"
NONE	-05.0	ERF8-XXX-05.0-DV-01	C-211-05.0-X	N.A.	N.A.	N.A.
	-07.0	ERF8-XXX-07.0-DV-01	C-211-07.0-X			
	** -10.0	ERF8-XXX-05.0-DV-01/ ERF8H-XXX-05.0-DV	C-211-07.0-X			
-L	-05.0	ERF8-XXX-05.0-DV-L	C-211-05.0-X	WT-30-01-F	0.94 [.037]	1.17 [.046]
-EGP	-07.0	ERF8-XXX-07.0-DV-EGP	C-211-07.0-X	WT-30-02-T	0.92 [.036]	1.17 [.046]
-EGPS	-07.0	ERF8-XXX-07.0-DV-EGPS	C-211-07.0-X	SH29-XX-01-X	0.94 [.037]	1.17 [.046]
-W	-05.0	ERF8-XXX-05.0-DV-L	C-211-05.0-X	WT-30-05-T	1.40 [.055]	1.64 [.060]
	-07.0	ERF8-XXX-07.0-DV-L	C-211-05.0-X	WT-30-07-T	1.40 [.055]	1.64 [.060]
-E	-07.0	ERF8-XXX-07.0-DV-EGP	C-211-07.0-X	WT-30-05-T	1.40 [.055]	1.64 [.060]
	-05.0	ERF8-XXX-05.0-DV-L	C-211-05.0-X	WT-30-04-F	1.40 [.055]	1.64 [.060]
-L2	-07.0	ERF8-XXX-07.0-DV-L	C-211-05.0-X	WT-30-06-F	1.40 [.055]	1.64 [.060]

(** = NOT TOOLED)

PROPRIETARY NOTE
THIS DOCUMENT CONTAINS INFORMATION CONFIDENTIAL AND PROPRIETARY TO SAMTEC, INC. AND SHALL NOT BE REPRODUCED OR TRANSFERRED TO OTHER DOCUMENTS OR DISCLOSED TO OTHERS OR USED FOR ANY PURPOSE OTHER THAN THAT WHICH IT WAS OBTAINED WITHOUT THE EXPRESSED WRITTEN CONSENT OF SAMTEC, INC.

DO NOT SCALE DRAWING

SHEET SCALE: 2:1



520 PARK EAST BLVD, NEW ALBANY, IN 47150
PHONE: 812-944-6733 FAX: 812-948-5047
e-Mail info@SAMTEC.com code 55322

DESCRIPTION:
0.8MM EDGE RATE SOCKET ASSEMBLY

DWG. NO.
ERF8-XXX-XX.X-X-DV-XXXX-TR

BY: KNOWLDEN 9/26/2005 SHEET 2 OF 6

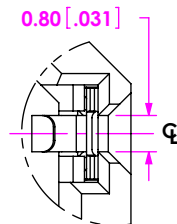
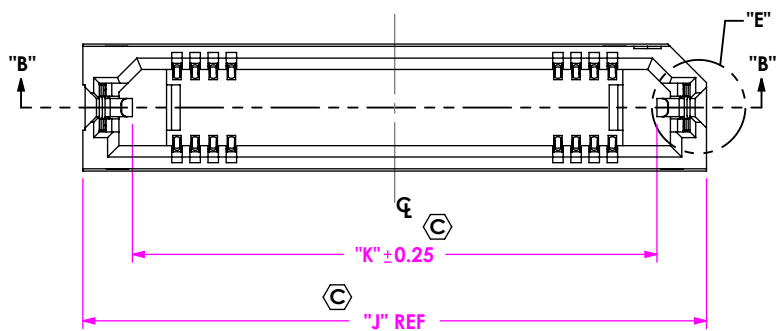

DETAIL "E"
SCALE 6:1

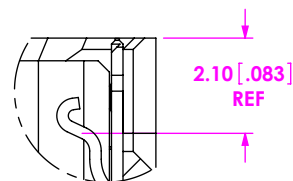

DETAIL "G"
SCALE 6:1

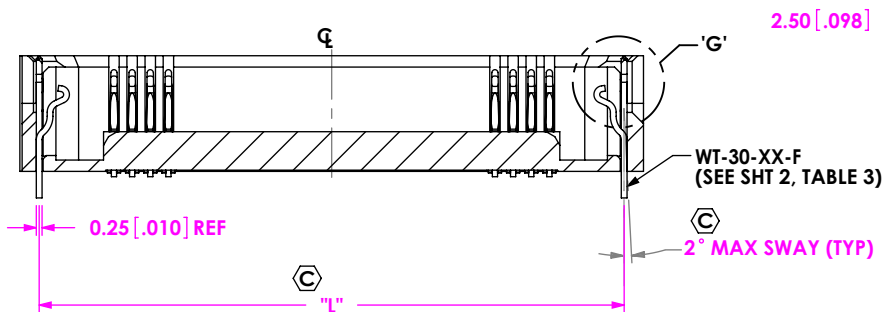

SECTION "B"- "B"
SCALE 3:1

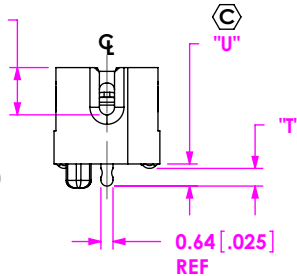

AF

TABLE 6

POSITION	"J"	"K"	"L"	"M"
-005	11.50 [.453]	7.13 [.281]	9.8 [.386]	2.75 [.108]
-010	15.50 [.610]	11.13 [.438]	13.8 [.543]	4.75 [.187]
-011	16.30 [.642]	11.93 [.470]	14.6 [.575]	5.15 [.203]
-013	17.90 [.705]	13.53 [.533]	16.2 [.638]	5.95 [.234]
-020	23.50 [.925]	19.13 [.753]	21.8 [.858]	8.75 [.344]
-023	25.90 [1.020]	21.53 [.848]	24.2 [.953]	9.95 [.391]
-025	27.50 [1.083]	23.13 [.911]	25.8 [1.016]	10.75 [.423]
-030	31.50 [1.240]	27.13 [1.068]	29.8 [1.173]	12.75 [.502]
-035	35.50 [1.398]	31.13 [1.226]	33.8 [1.330]	14.75 [.581]
-040	39.50 [1.555]	35.13 [1.383]	37.8 [1.488]	16.75 [.659]
-049	46.70 [1.839]	42.33 [1.667]	45.0 [1.772]	20.35 [.801]
-050	47.50 [1.870]	43.13 [1.698]	45.8 [1.803]	20.75 [.817]
-060	55.50 [2.185]	51.13 [2.013]	53.8 [2.118]	24.75 [.974]
-070	63.50 [2.500]	59.13 [2.328]	61.8 [2.433]	28.75 [1.132]
-075	67.50 [2.657]	63.13 [2.485]	65.8 [2.591]	30.75 [1.211]

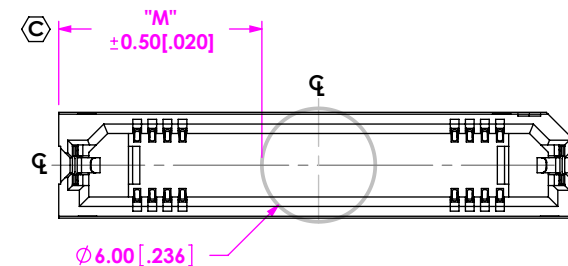

FIG 5
(ERF8-025-05.0-X-DV-K-L SHOWN)
(SAME AS FIG 1 & 2, EXCEPT AS SHOWN)
(CENTER FEATURES REMOVED FOR CLARITY)

PROPRIETARY NOTE

THIS DOCUMENT CONTAINS INFORMATION CONFIDENTIAL AND PROPRIETARY TO SAMTEC, INC. AND SHALL NOT BE REPRODUCED OR TRANSFERRED TO OTHER DOCUMENTS OR DISCLOSED TO OTHERS OR USED FOR ANY PURPOSE OTHER THAN THAT WHICH IT WAS OBTAINED WITHOUT THE EXPRESSED WRITTEN CONSENT OF SAMTEC, INC.

DO NOT SCALE DRAWING

SHEET SCALE: 2:1

samtec

520 PARK EAST BLVD, NEW ALBANY, IN 47150
PHONE: 812-944-6733 FAX: 812-948-5047
e-Mail info@SAMTEC.com code 55322

DESCRIPTION:
0.8MM EDGE RATE SOCKET ASSEMBLY

DWG. NO.
ERF8-XXX-XX.X-X-DV-XXXX-TR

BY: KNOWLDEN 9/26/2005 SHEET 3 OF 6

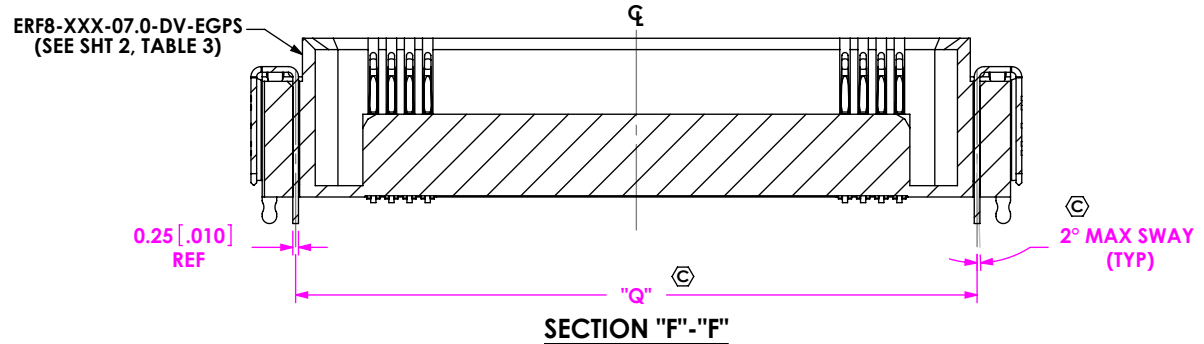
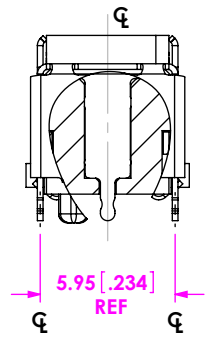
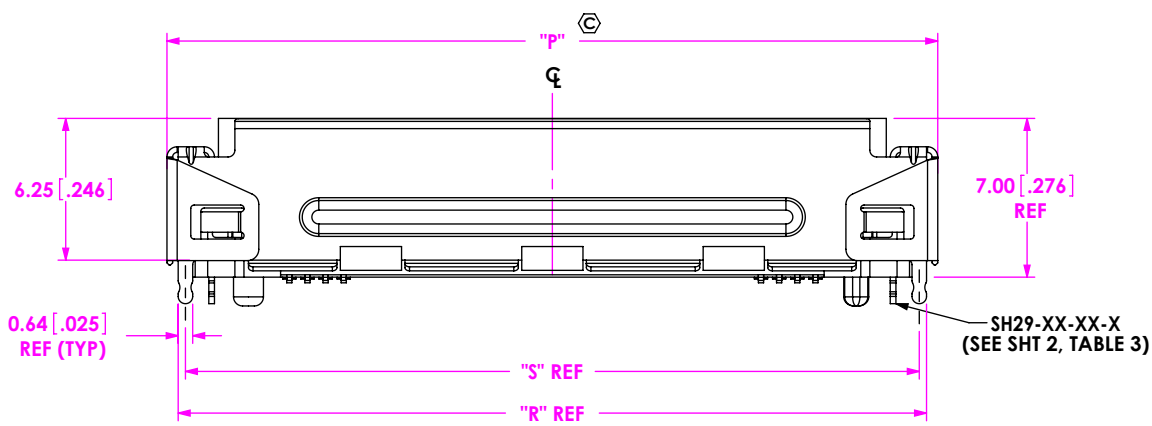
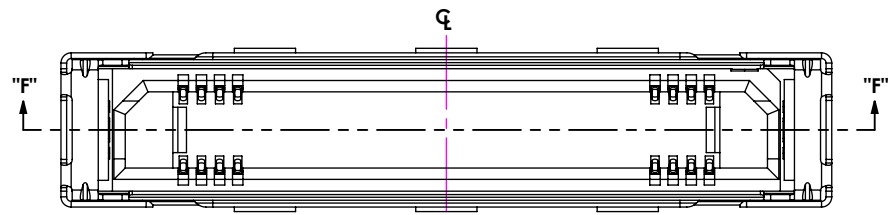
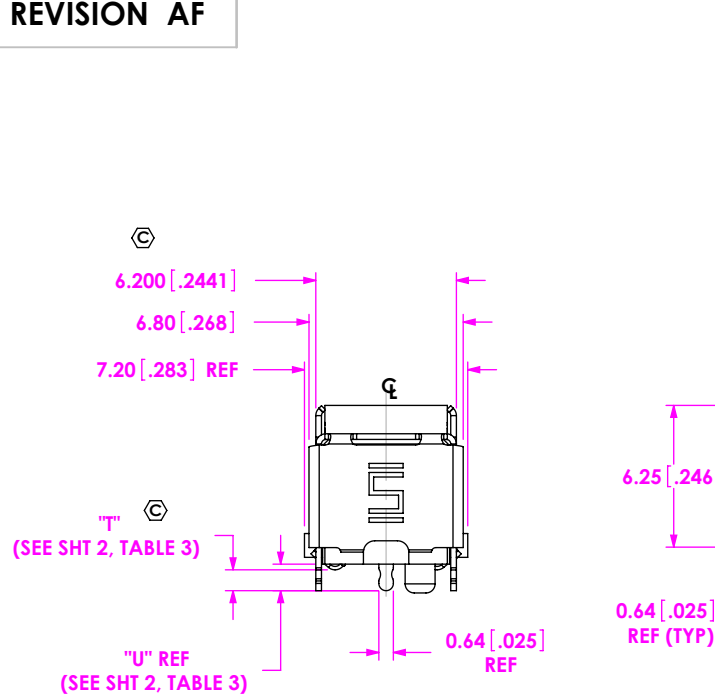

FIG 6
 (ERF8-030-07.0-X-EGPS SHOWN)
 (SAME AS FIG 3, EXCEPT AS SHOWN)
 (AVAILABLE ON -07.0 LEAD STYLE ONLY)
 (CENTER FEATURES REMOVED FOR CLARITY)

TABLE 8

No. OF POS.	"P"	"Q"	"R"	"S"
-10	18.0 [.71]	14.00 [.551]	17.00 [.669]	16.36 [.644]
-20	26.0 [1.02]	22.00 [.866]	25.00 [.984]	24.36 [.959]
-25	30.0 [1.18]	26.00 [1.024]	29.00 [1.142]	28.36 [1.117]
-30	34.0 [1.34]	30.00 [1.181]	33.00 [1.299]	32.36 [1.274]

PROPRIETARY NOTE
 THIS DOCUMENT CONTAINS INFORMATION CONFIDENTIAL AND PROPRIETARY TO SAMTEC, INC. AND SHALL NOT BE REPRODUCED OR TRANSFERRED TO OTHER DOCUMENTS OR DISCLOSED TO OTHERS OR USED FOR ANY PURPOSE OTHER THAN THAT WHICH IT WAS OBTAINED WITHOUT THE EXPRESSED WRITTEN CONSENT OF SAMTEC, INC.

DO NOT SCALE DRAWING

SHEET SCALE: 3:1

520 PARK EAST BLVD, NEW ALBANY, IN 47150
 PHONE: 812-944-6733 FAX: 812-948-5047
 e-Mail info@SAMTEC.com code 55322

DESCRIPTION:
0.8MM EDGE RATE SOCKET ASSEMBLY

DWG. NO.
ERF8-XXX-XX.X-X-DV-XXXX-TR

BY: KNOWLDEN 9/26/2005 SHEET 4 OF 6

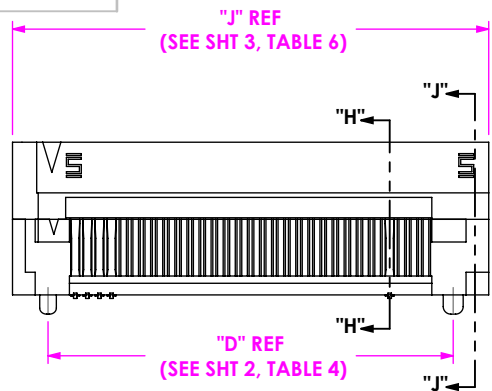

FIG 8
-EGPS OPTIONS
(**ERF8-030-10.0-X-DV-L SHOWN)
(SAME AS FIG 7, EXCEPT AS SHOWN)
** NOT TOOLED

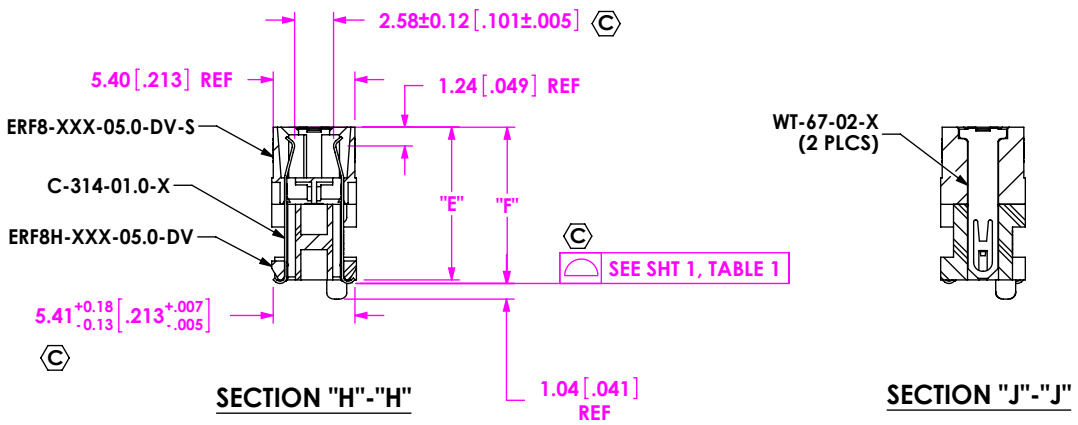

FIG 7
(**ERF8-030-10.0-X-DV SHOWN)
(CENTER FEATURES REMOVED FOR CLARITY)
** NOT TOOLED

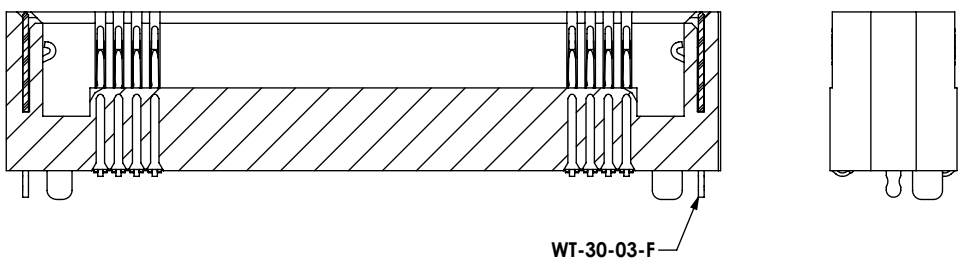
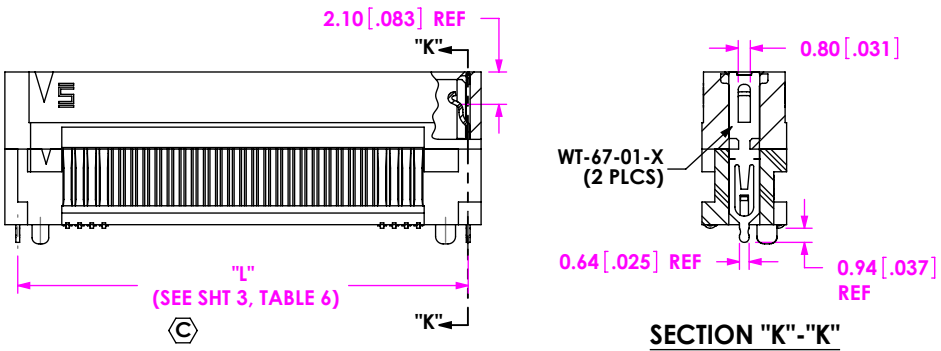

FIG 9
(**ERF8-030-07.0-X-DV-L SHOWN)
(SAME AS FIG 5, EXCEPT AS SHOWN)
(CENTER FEATURES REMOVED FOR CLARITY)
** NOT TOOLED

PROPRIETARY NOTE
THIS DOCUMENT CONTAINS INFORMATION
CONFIDENTIAL AND PROPRIETARY TO
SAMTEC, INC. AND SHALL NOT BE REPRODUCED
OR TRANSFERRED TO OTHER DOCUMENTS OR
DISCLOSED TO OTHERS OR USED FOR ANY
PURPOSE OTHER THAN THAT WHICH IT WAS
OBTAINED WITHOUT THE EXPRESSED WRITTEN
CONSENT OF SAMTEC, INC.



520 PARK EAST BLVD, NEW ALBANY, IN 47150
PHONE: 812-944-6733 FAX: 812-948-5047
e-Mail info@SAMTEC.com code 55322

DO NOT SCALE DRAWING

SHEET SCALE: 2:1

DESCRIPTION:
0.8MM EDGE RATE SOCKET ASSEMBLY

DWG. NO.
ERF8-XXX-XX.X-X-DV-XXXX-TR

BY:KNOWLDEN 9/26/2005 SHEET 5 OF 6

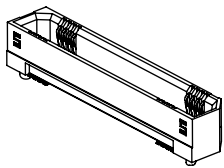

-05.0 SHOWN

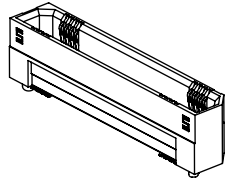

-07.0 SHOWN

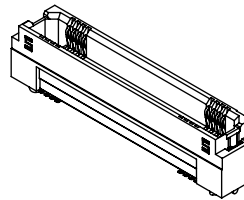

-07.0 WITH EGP SHOWN

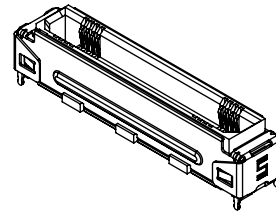

-07.0 WITH EGPS SHOWN

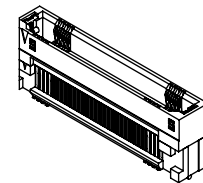

** -10.0 WITH -L SHOWN

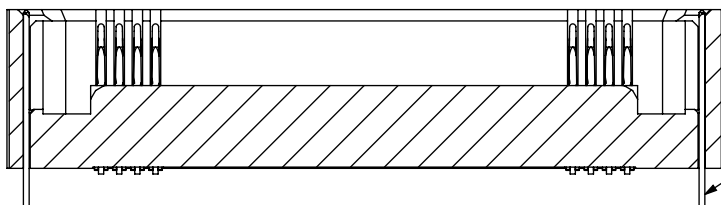
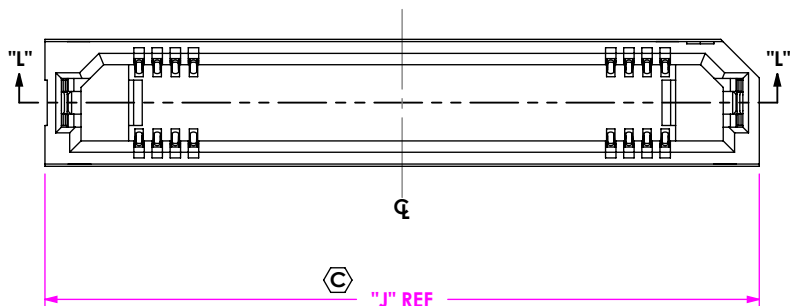

WT-30-05-X
(SEE TABLE 3)

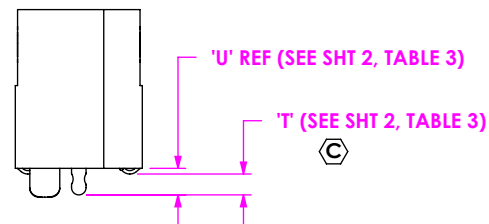

SECTION "L"-"L"
SCALE 3 : 1

FIG 10
(ERF8-025-05.0-X-DV-W SHOWN)
(SAME AS FIG 5 EXCEPT AS SHOWN)
(CENTER FEATURES REMOVED FOR CLARITY)

PROPRIETARY NOTE

THIS DOCUMENT CONTAINS INFORMATION CONFIDENTIAL AND PROPRIETARY TO SAMTEC, INC. AND SHALL NOT BE REPRODUCED OR TRANSFERRED TO OTHER DOCUMENTS OR DISCLOSED TO OTHERS OR USED FOR ANY PURPOSE OTHER THAN THAT WHICH IT WAS OBTAINED WITHOUT THE EXPRESSED WRITTEN CONSENT OF SAMTEC, INC.

DO NOT SCALE DRAWING

SHEET SCALE: 2:1



520 PARK EAST BLVD, NEW ALBANY, IN 47150
PHONE: 812-944-6733 FAX: 812-948-5047
e-Mail info@SAMTEC.com code 55322

DESCRIPTION:
0.8MM EDGE RATE SOCKET ASSEMBLY

DWG. NO.
ERF8-XXX-XX.X-X-DV-XXXX-TR

BY: KNOWLDEN 9/26/2005 SHEET 6 OF 6