

DO NOT SCALE FROM THIS PRINT

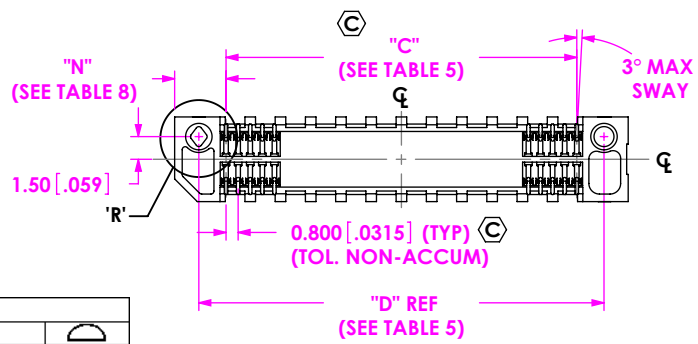
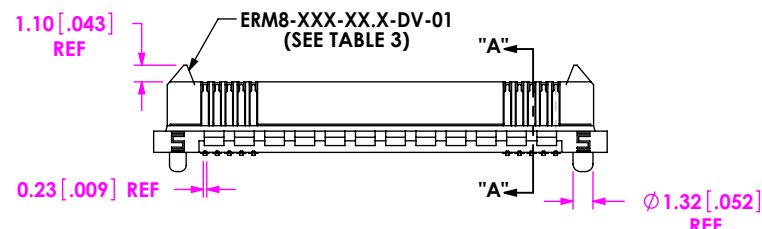
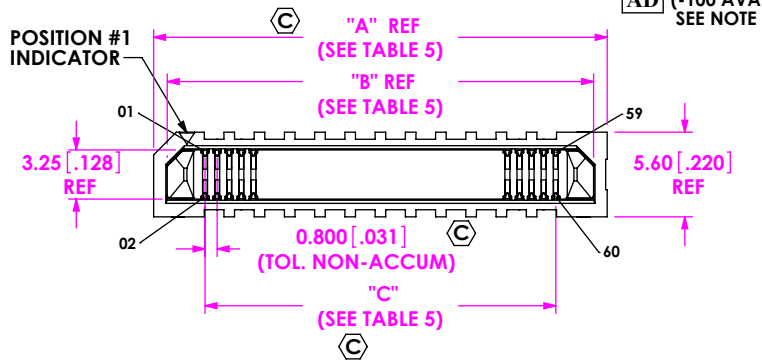

No OF POSITIONS (PER ROW)
 -005, -010, -011, -013, -020, -025, -030, -035, -040, -049, -050, -060, -070, -075, -100
 (-100 AVAILABLE ON -09.0 LEAD STYLE ONLY SEE NOTE 8)

LEAD STYLE
 -02.0 = 2mm
 -05.0 = 5mm
 -08.0 = 8mm
 -09.0 = 9mm
 ***-15.0 = 15mm

PLATING SPECIFICATION
 -L: 10µ" LIGHT SELECTIVE GOLD IN CONTACT AREA, MATTE TIN ON TAIL
 -S: 30µ" SELECTIVE GOLD IN CONTACT AREA, MATTE TIN ON TAIL

ROW SPECIFICATION
 -DV: DOUBLE VERTICAL

** = NOT RELEASED FOR PRODUCTION
 *** = NOT TOOLED

TAPE & REEL (STANDARD PACKAGING) (SEE NOTES 4 & 7)

- OPTIONS
- K: POLYIMIDE FILM PAD (FOR -EGP & EGPS OPTIONS USE K-DOT-.157-.250-.005) (FOR ALL OTHER OPTIONS USE K-500-300)
 - DS: DIFFERENTIAL PAIR (HOT SWAP) (AVAILABLE ONLY ON -05.0 LEAD STYLE) (SEE TABLE 4 FOR POSITION AVAILABILITY)
 - L: LATCHES (AVAILABLE ONLY ON -05.0, -08.0, -09.0 & ***-15.0 LEAD STYLES. -L ON -08.0 & -09.0 NOT TOOLED) (SEE TABLE FOR AVAILABILITY) (NOT AVAILABLE WITH -EGP, -L2, -W, -EGP, -EGPS OPTIONS)
 - *** -L2: LATCHES WITH LONG WELD TAB (AVAILABLE ONLY ON -05.0, -08.0 & .09.0 LEAD STYLES)(NOT AVAILABLE WITH -L, -E, -W, -EGP AND -EGPS OPTIONS)
 - *** -E: EXTENDED GUIDE POSTS, WITH LONG WELD TAB (AVAILABLE ONLY ON -05.0, -08.0 & .09.0 LEAD STYLES, NOT AVAILABLE WITH -L OPTION, SEE NOTE 6)
 - *** -W: WELD TAB (AVAILABLE ONLY ON -05.0, -08.0 & .09.0 LEAD STYLES)
 - EGP: EXTENDED GUIDE POSTS (AVAILABLE ONLY ON -05.0 LEAD STYLE) (NOT AVAILABLE WITH -L OPTION)
 - EGPS: EXTENDED GUIDE POST SHIELD (AVAILABLE ONLY ON -05.0 LEAD STYLE) (NOT AVAILABLE WITH -L OPTION) (-10, -20, -25, & -30 POSITIONS ONLY)

NOTES:

- ⊕ REPRESENTS A CRITICAL DIMENSION.
- BURR ALLOWANCE: 0.038[.0015] MAX.
- MINIMUM PUSHOUT FORCE: TERMINAL 2.22 N [.5 LB.], WELD TAB 4.45 N [1 LB.]
- FOR QUANTITY UP TO 49 PIECES, NO LEADER, TRAILER, OR EIA-481-D REEL WILL BE SUPPLIED. FOR QUANTITY OF 50-124 PIECES, NO LEADER OR TRAILER WILL BE SUPPLIED.
- "F" DIMENSION DOES NOT APPLY TO -EGP & -EGPS OPTION, SEE FIG. 5 & 6.
- NOTE DELETED.
- TR PACKAGING NOT AVAILABLE ON THE 100 POSITION.
- NOT AVAILABLE WITH -L, -L2, -E OR -W OPTIONS.

No. OF POS.	
-005, -010, -011, -013, -020, -025, -030, -035	0.10 [.004]
-040, -049, -050, -060	0.12 [.005]
-070, -075, -100	0.15 [.006]

POSITION	"A"	"B"	"C"	"D"	"H"
-005	10.00 [1.394]	8.20 [3.23]	3.200 [1.260]	6.80 [2.68]	3.00 [.128]
-010	14.00 [1.551]	12.20 [4.80]	7.200 [2.835]	10.80 [4.25]	5.00 [1.97]
-011	14.80 [1.583]	13.00 [5.12]	8.000 [3.150]	11.60 [4.57]	5.40 [2.12]
-013	16.40 [1.648]	14.60 [5.75]	9.600 [3.780]	13.20 [5.20]	6.20 [2.44]
-020	22.00 [1.866]	20.20 [7.95]	15.200 [5.984]	18.80 [7.40]	9.00 [3.54]
-025	26.00 [1.024]	24.20 [1.953]	19.200 [7.559]	22.80 [8.98]	11.00 [4.33]
-030	30.00 [1.181]	28.20 [1.110]	23.200 [9.134]	26.80 [1.056]	13.00 [5.12]
-035	34.00 [1.339]	32.20 [1.268]	27.200 [1.0709]	30.80 [1.213]	15.00 [5.90]
-040	38.00 [1.496]	36.20 [1.425]	31.200 [1.2283]	34.80 [1.370]	17.00 [6.69]
-049	45.20 [1.780]	43.40 [1.709]	38.400 [1.5118]	42.00 [1.654]	20.80 [8.11]
-050	46.00 [1.811]	44.20 [1.740]	39.200 [1.543]	42.80 [1.685]	21.00 [8.27]
-060	54.00 [2.126]	52.20 [2.055]	47.20 [1.858]	50.80 [2.000]	25.00 [9.84]
-070	62.00 [2.441]	60.20 [2.370]	55.20 [2.173]	58.80 [2.315]	29.00 [1.142]
-075	66.00 [2.598]	64.20 [2.528]	59.20 [2.331]	62.80 [2.472]	31.00 [1.220]
-100	86.00 [3.386]	84.20 [3.315]	79.20 [3.118]	82.80 [3.260]	41.00 [1.614]

ERM8 LEAD STYLE	STACK HEIGHT		
	-05.0	-07.0	***-10.0
-02.0	7.0MM	9.0MM	12.0MM
-05.0	10.0MM	12.0MM	15.0MM
-08.0	13.0MM	15.0MM	18.0MM
-09.0	14.0MM	18.0MM	19.0MM
***-15.0	20.0MM	22.0MM	25.0MM

(*** = NOT TOOLED)

FIG 1 (ERM8-030-02.0-X-DV-XX SHOWN) (SOME CENTER FEATURES REMOVED FOR CLARITY)

OPTION	"N"
NONE	3.40 [.134]
-W, -L, -L2, -EGP	4.90 [.193]

HEIGHT	"E"	"F"	"G"
-02.0	1.605 [.0632]	5.965 [.2348]	5.04 [.198]
-05.0	4.605 [.1813]	8.905 [.3506]	7.98 [.314]
-08.0	7.605 [.2994]	11.905 [.4687]	10.98 [.432]
-09.0	8.605 [.3411]	12.905 [.5081]	11.98 [.472]
***-15.0	14.605 [.5750]	18.905 [.7443]	17.98 [.708]

(*** = NOT TOOLED)

UNLESS OTHERWISE SPECIFIED, DIMENSIONS ARE IN MILLIMETERS [INCHES].
 TOLERANCES ARE:
 DECIMALS ANGLES
 X.X: ±0.3 [.01] 2°
 X.XX: ±0.13 [.005]
 X.XXX: ±0.050 [.0020]

PROPRIETARY NOTE
 THIS DOCUMENT CONTAINS INFORMATION CONFIDENTIAL AND PROPRIETARY TO SAMTEC, INC. AND SHALL NOT BE REPRODUCED OR TRANSFERRED TO OTHER DOCUMENTS OR DISCLOSED TO OTHERS OR USED FOR ANY PURPOSE OTHER THAN THAT WHICH IT WAS OBTAINED WITHOUT THE EXPRESSED WRITTEN CONSENT OF SAMTEC, INC.

MATERIAL: DO NOT SCALE DRAWING SHEET SCALE: 2:1
 INSULATOR: LCP, COLOR: BLACK
 TERMINAL: PHOS BRONZE
 LATCH: BeCu
 SHIELD: PHOS BRONZE

F:\DWG\MISC\MKTG\ERM8-XXX-XX.X-X-DV-XXXX-TR-MKT.SLDDRW

520 PARK EAST BLVD, NEW ALBANY, IN 47150
 PHONE: 812-944-6733 FAX: 812-948-5047
 e-Mail info@SAMTEC.com code 55322

DESCRIPTION:
0.8MM EDGE RATE TERMINAL ASSEMBLY

DWG. NO.
ERM8-XXX-XX.X-X-DV-XXXX-TR

BY: KNOWLDEN 9/27/2005 SHEET 1 OF 6

REVISION AD

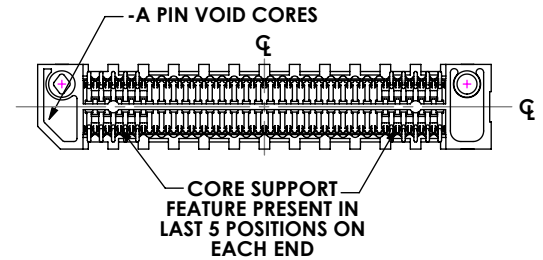
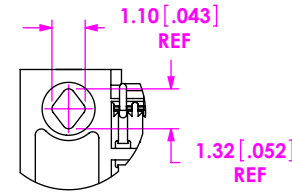
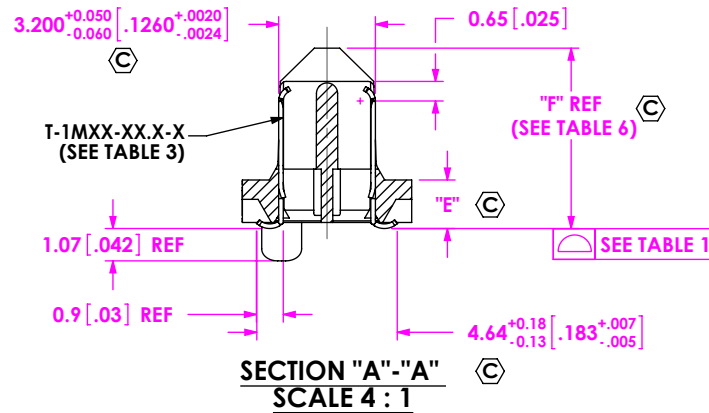

BOTTOM VIEW
(ERM8-030-09.0-X-DV-XX SHOWN)
(DIFFERENT AS SHOWN, OTHERWISE SAME AS FIG 1)

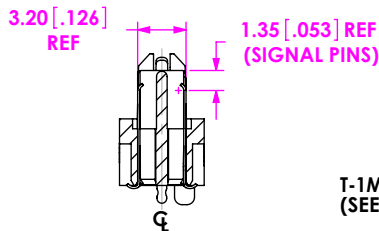

SECTION "N"-"N"

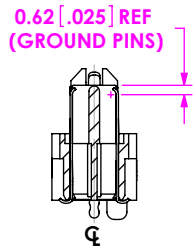

SECTION "P"-"P"

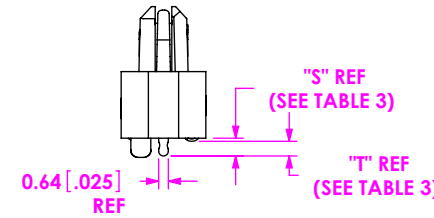
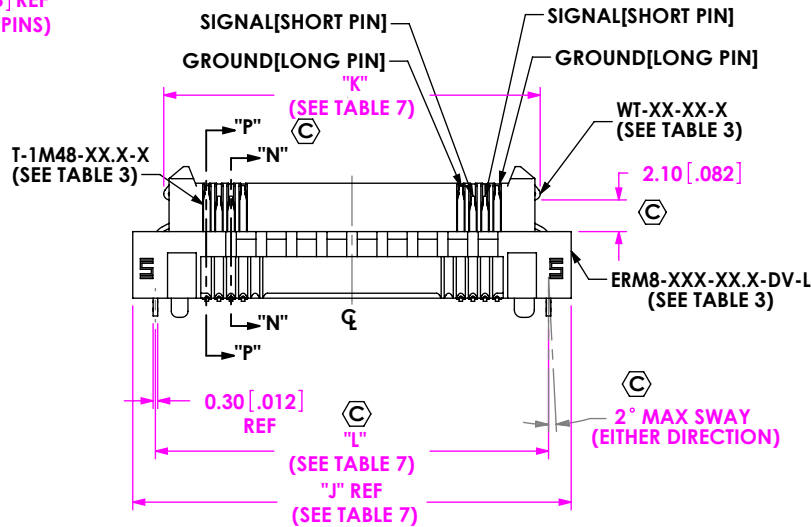

FIG 3
-DS WITH -L OR -L2 OPTIONS
(-DS AVAILABLE ON -05.0 LEADSTYLE ONLY)
(-L AVAILABLE ON -05.0, -08.0, -09.0 & ***.15.0 LEAD STYLES ONLY)
(-L ON -08.0 & -09.0 NOT TOOLED)
(ERM8-025-05.0-X-DV-DS-L SHOWN)
(SAME AS FIG 1, EXCEPT AS SHOWN)
(SOME CENTER FEATURES REMOVED FOR CLARITY)

AD

TABLE 4	
-DS & -L OPTION AVAILABILITY	
(-DS AVAILABLE ON -05.0 LEADSTYLE ONLY) (-L AVAILABLE ON -05.0, -08.0, -09.0 & ***15.0 LEADSTYLES ONLY. -L ON -08.0 & -09.0 NOT TOOLED)	
POSITION	
-005	-L, -L2, -W
-010	-DS, -L, -L2, -W
-011	-L, -L2, -W
-013	-DS, -L, -L2, -W
-020	-L, -L2, -W
-025	-DS, -L, -L2, -W
-030	-L, -L2, -W
-035	-L, -L2, -W
-040	-L, -L2, -W
-049	-DS, -L, -L2, -W
-050	-L, -L2, -W
-060	-L, -L2, -W
-070	-L, -L2, -W
-075	-L, -L2, -W

TABLE 3						
OPTION	STYLE	ERM8-XXX-XX.X-DV-01	T-1MXX-XX.X-X	WT-XX-XX-X	"S"	"T"
NONE	-02.0	ERM8-XXX-02.0-DV-01	T-1M37-02.0-X		N/A	
	-05.0	ERM8-XXX-05.0-DV-01	T-1M37-05.0-X			
	-08.0	ERM8-XXX-08.0-DV-01	T-1M37-08.0-X			
	-09.0	ERM8-XXX-09.0-DV-01	T-1M37-09.0-X			
	***.15.0	ERM8-XXX-05.0-DV-01/ERM8H-XXX-10.0-DV	T-1M88-0.10-X			
-DS		ERM8-XXX-05.0-DV-XX	T-1M48-05.0-X		N/A	
-EGP	-05.0	ERM8-XXX-05.0-DV-EGP	T-1M37-05.0-X	WT-29-06-T 1.17 [.046]	0.97 [.038]	
-EGPS		ERM8-XXX-05.0-DV-EGPS	T-1M37-05.0-X	SH29-XX-02 1.17 [.046]	0.97 [.038]	
-L	-05.0	ERM8-XXX-05.0-DV-L	T-1M37-05.0-X	WT-29-03-F 1.17 [.046]	0.97 [.038]	
		ERM8-XXX-05.0-EGP	T-1M37-05.0-X	WT-29-09-T 1.60 [.083]	1.40 [.055]	
		ERM8-XXX-08.0-EGP	T-1M37-08.0-X	WT-66-05-T 1.60 [.083]	1.40 [.055]	
		ERM8-XXX-09.0-EGP	T-1M37-09.0-X	WT-66-06-T 1.60 [.083]	1.40 [.055]	
***-E	-05.0	ERM8-XXX-05.0-DV-L	T-1M37-05.0-X	WT-29-09-T 1.60 [.083]	1.40 [.055]	
		ERM8-XXX-05.0-DV-L	T-1M37-05.0-X	WT-29-09-T 1.60 [.083]	1.40 [.055]	
		ERM8-XXX-09.0-DV-L	T-1M37-09.0-X	WT-66-06-T 1.60 [.083]	1.40 [.055]	
		ERM8-XXX-05.0-DV-L	T-1M37-05.0-X	WT-29-08-F 1.60 [.083]	1.40 [.055]	
***-W	-05.0	ERM8-XXX-05.0-DV-L	T-1M37-05.0-X	WT-66-03-F 1.60 [.083]	1.40 [.055]	
		ERM8-XXX-05.0-DV-L	T-1M37-05.0-X	WT-66-03-F 1.60 [.083]	1.40 [.055]	
		ERM8-XXX-09.0-DV-L	T-1M37-09.0-X	WT-66-06-T 1.60 [.083]	1.40 [.055]	
		ERM8-XXX-05.0-DV-L	T-1M37-05.0-X	WT-66-04-F 1.60 [.083]	1.40 [.055]	

(*** = NOT TOOLED)

AD

TABLE 7				
POSITION	"J"	"K"	"L"	"M"
-005	13.00 [.512]	8.90 [.350]	10.00 [.394]	4.50 [.177]
-010	17.00 [.669]	12.90 [0.508]	14.00 [.551]	6.50 [.256]
-011	17.80 [.701]	13.70 [0.539]	14.80 [.583]	6.90 [.271]
-013	19.40 [.764]	15.30 [0.602]	16.40 [.646]	7.75 [.303]
-020	25.00 [.984]	20.90 [0.823]	22.00 [.866]	10.50 [.413]
-025	29.00 [1.142]	24.90 [0.980]	26.00 [1.024]	12.50 [.492]
-030	33.00 [1.299]	28.90 [1.138]	30.00 [1.181]	14.50 [.571]
-035	37.00 [1.457]	32.90 [1.295]	34.00 [1.339]	16.50 [.649]
-040	41.00 [1.614]	36.90 [1.453]	38.00 [1.496]	18.50 [.728]
-049	48.20 [1.898]	44.10 [1.736]	45.20 [1.780]	22.10 [.870]
-050	49.00 [1.929]	44.90 [1.768]	46.00 [1.811]	22.50 [.886]
-060	57.00 [2.244]	52.90 [2.083]	54.00 [2.126]	26.50 [1.043]
-070	65.00 [2.559]	60.90 [2.398]	62.00 [2.441]	30.50 [1.201]
-075	69.00 [2.717]	64.90 [2.555]	66.00 [2.598]	32.50 [1.279]

PROPRIETARY NOTE
THIS DOCUMENT CONTAINS INFORMATION CONFIDENTIAL AND PROPRIETARY TO SAMTEC, INC. AND SHALL NOT BE REPRODUCED OR TRANSFERRED TO OTHER DOCUMENTS OR DISCLOSED TO OTHERS OR USED FOR ANY PURPOSE OTHER THAN THAT WHICH IT WAS OBTAINED WITHOUT THE EXPRESSED WRITTEN CONSENT OF SAMTEC, INC.

DO NOT SCALE DRAWING

SHEET SCALE: 2:1



520 PARK EAST BLVD, NEW ALBANY, IN 47150
PHONE: 812-944-6733 FAX: 812-948-5047
e-Mail info@SAMTEC.com code 55322

DESCRIPTION:
0.8MM EDGE RATE TERMINAL ASSEMBLY

DWG. NO.
ERM8-XXX-XX.X-X-DV-XXXX-TR

BY: KNOWLDEN 9/27/2005 SHEET 2 OF 6

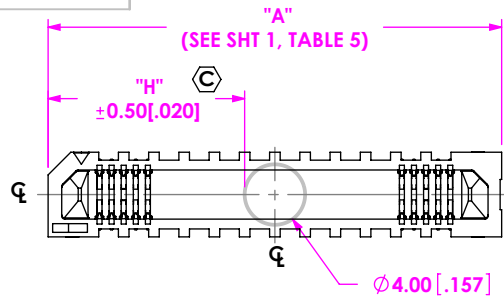

FIG 2
 -K OPTION
 (FOR -EGP, -E OR -ES OPTIONS USE K-DOT-.157-.250-.005)
 (USE K-500-300 FOR ALL OTHER OPTIONS)
 (ERM8-030-XX.X-X-DV-K SHOWN)
 (SOME CENTER FEATURES REMOVED FOR CLARITY)

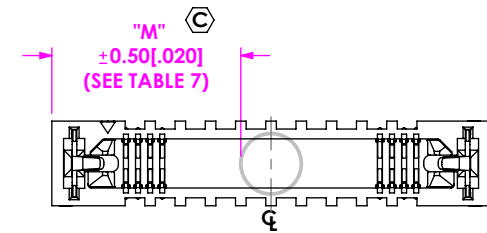
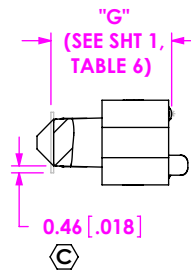

FIG 4
 -K WITH -L, -L2 OR -W OPTIONS
 (ERM8-025-05.0-X-DV-K-L SHOWN)
 (SAME AS FIG 2, EXCEPT AS SHOWN)
 (SOME CENTER FEATURES REMOVED FOR CLARITY)

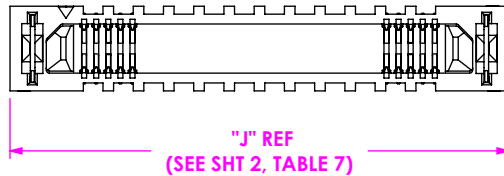
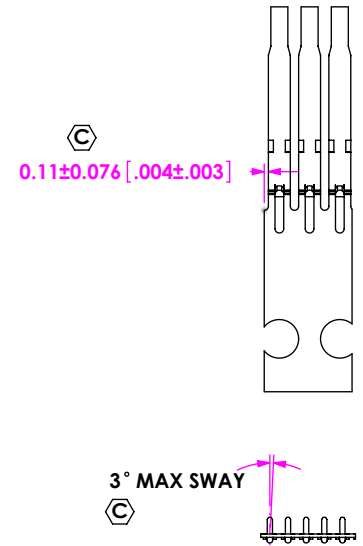
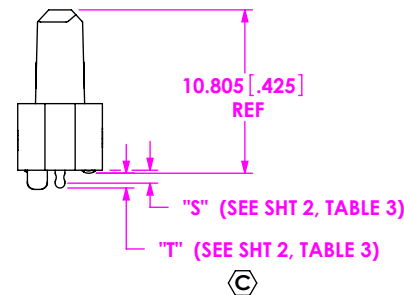
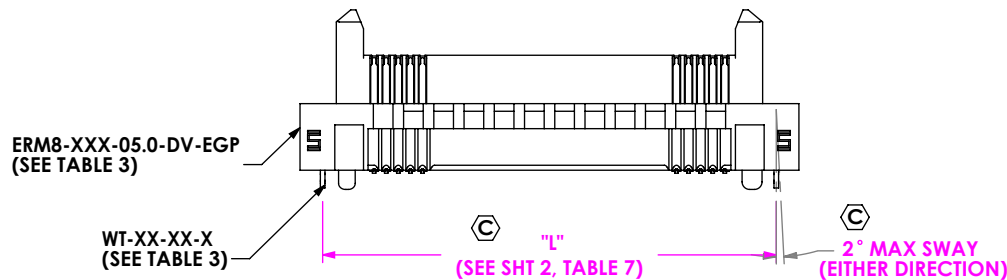

FIG 5
 -EGP AND -E OPTIONS
 (AVAILABLE ON -.05.0 LEAD STYLE ONLY)
 (ERM8-030-05.0-X-DV-EGP SHOWN)
 (SAME AS FIG 3, EXCEPT AS SHOWN)
 (SOME CENTER FEATURES REMOVED FOR CLARITY)



T-1M37-XX.X-X
IN-PROCESS VIEW

PROPRIETARY NOTE

THIS DOCUMENT CONTAINS INFORMATION CONFIDENTIAL AND PROPRIETARY TO SAMTEC, INC. AND SHALL NOT BE REPRODUCED OR TRANSFERRED TO OTHER DOCUMENTS OR DISCLOSED TO OTHERS OR USED FOR ANY PURPOSE OTHER THAN THAT WHICH IT WAS OBTAINED WITHOUT THE EXPRESSED WRITTEN CONSENT OF SAMTEC, INC.

DO NOT SCALE DRAWING

SHEET SCALE: 2:1

samtec

520 PARK EAST BLVD, NEW ALBANY, IN 47150
 PHONE: 812-944-6733 FAX: 812-948-5047
 e-Mail info@SAMTEC.com code 55322

DESCRIPTION:
0.8MM EDGE RATE TERMINAL ASSEMBLY

DWG. NO.
ERM8-XXX-XX.X-X-DV-XXXX-TR

BY: KNOWLDEN 9/27/2005 SHEET 3 OF 6

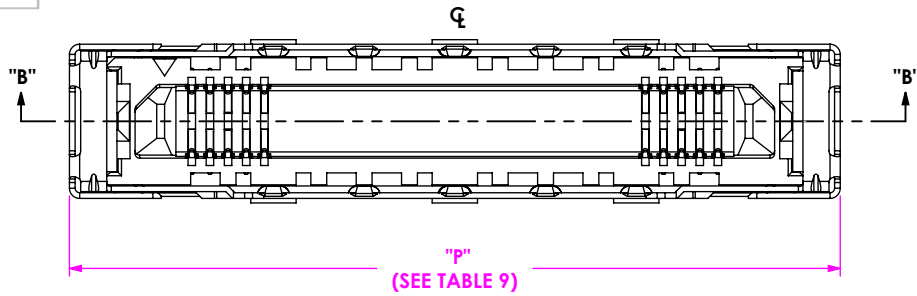

ERM8-XXX-05.0-DV-EGPS
(SEE TABLE 3)

SH29-XX-02-X

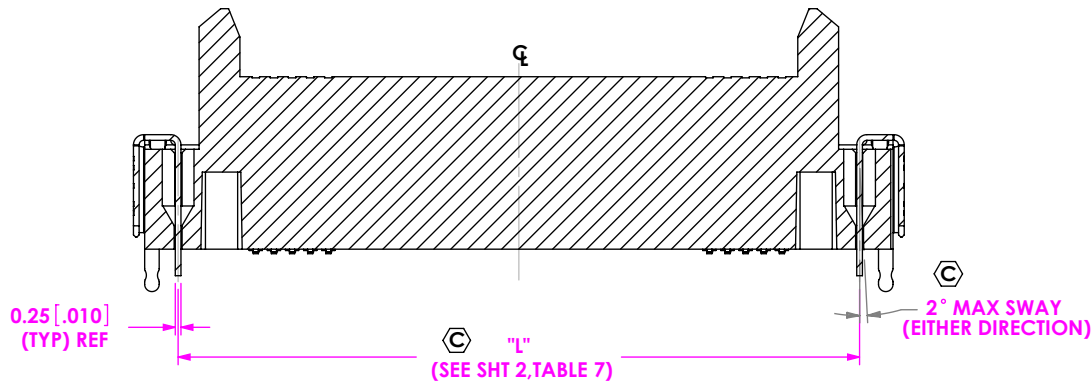
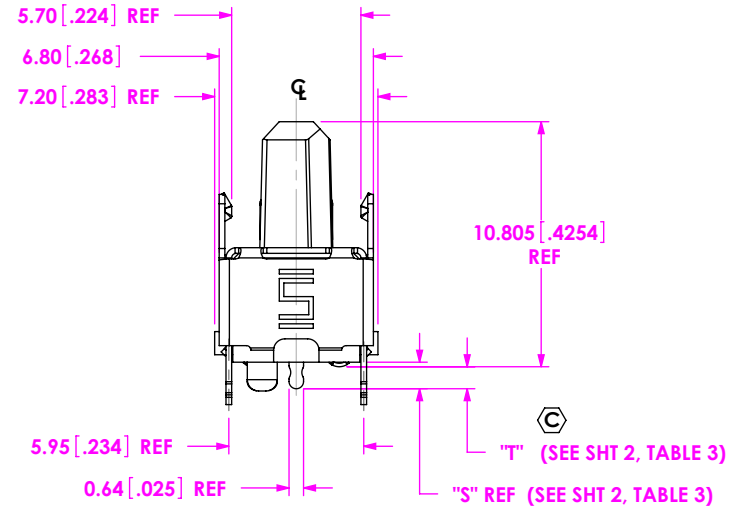
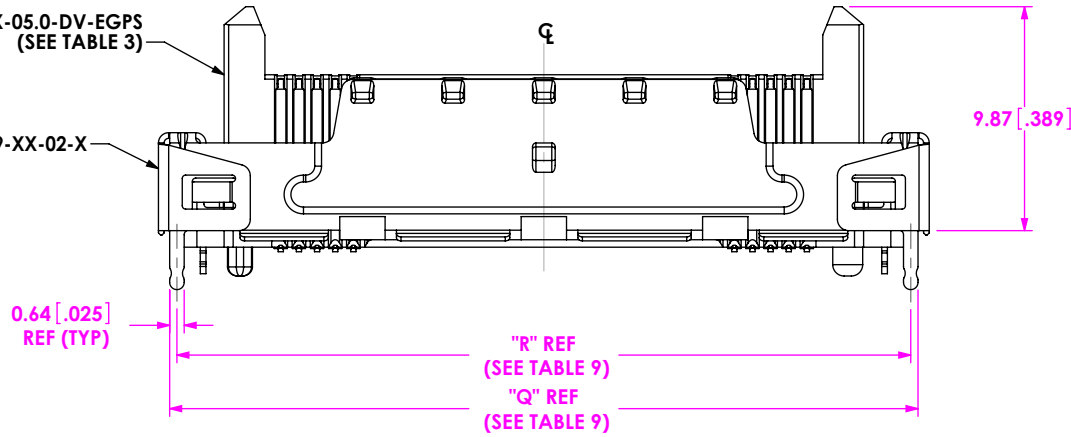

SECTION "B"-"B"

TABLE 9

No. OF POS.	"P"	"Q"	"R"
-10	18.0 [0.71]	17.00 [0.669]	16.36 [0.644]
-20	26.0 [1.02]	25.00 [0.984]	24.36 [0.959]
-25	30.0 [1.18]	29.00 [1.142]	28.36 [1.117]
-30	34.0 [1.34]	33.00 [1.299]	32.36 [1.274]

FIG 6
-EGPS OPTIONS
(AVAILABLE ON -05.0 LEAD STYLE ONLY)
(ERM8-030-05.0-X-DV-EGPS SHOWN)
(SAME AS FIG 5, EXCEPT AS SHOWN)

PROPRIETARY NOTE

THIS DOCUMENT CONTAINS INFORMATION CONFIDENTIAL AND PROPRIETARY TO SAMTEC, INC. AND SHALL NOT BE REPRODUCED OR TRANSFERRED TO OTHER DOCUMENTS OR DISCLOSED TO OTHERS OR USED FOR ANY PURPOSE OTHER THAN THAT WHICH IT WAS OBTAINED WITHOUT THE EXPRESSED WRITTEN CONSENT OF SAMTEC, INC.

DO NOT SCALE DRAWING

SHEET SCALE: 3:1



520 PARK EAST BLVD, NEW ALBANY, IN 47150
PHONE: 812-944-6733 FAX: 812-948-5047
e-Mail info@SAMTEC.com code 55322

DESCRIPTION:
0.8MM EDGE RATE TERMINAL ASSEMBLY

DWG. NO.
ERM8-XXX-XX.X-X-DV-XXXX-TR

BY: KNOWLDEN9/27/2005 SHEET 4 OF 6

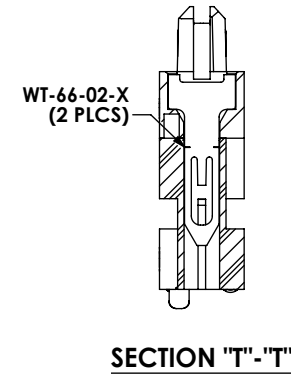
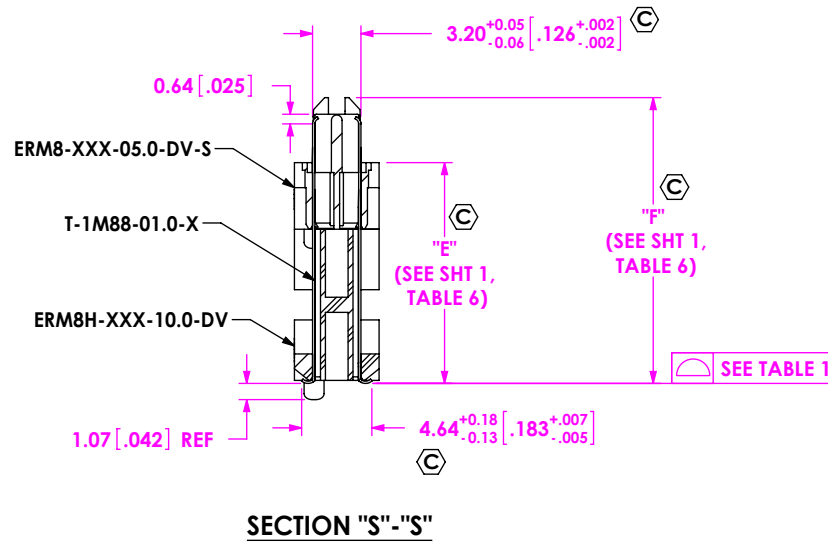
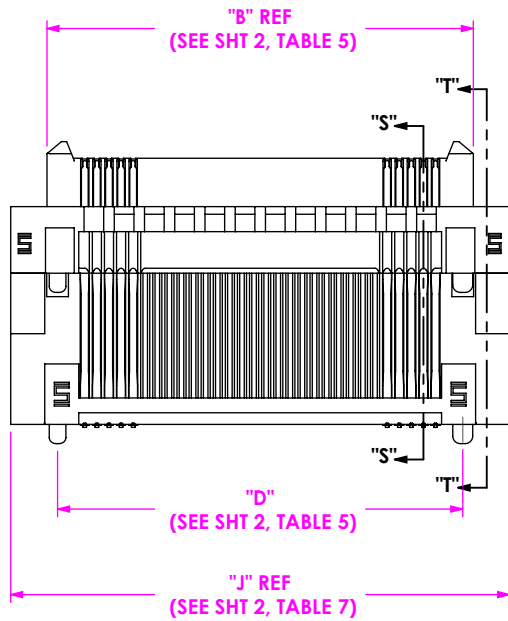

FIG 7
 (**ERM8-030-15.0-X-DV SHOWN)
 (SOME CENTER FEATURES REMOVED FOR CLARITY)
 ***NOT TOOLED

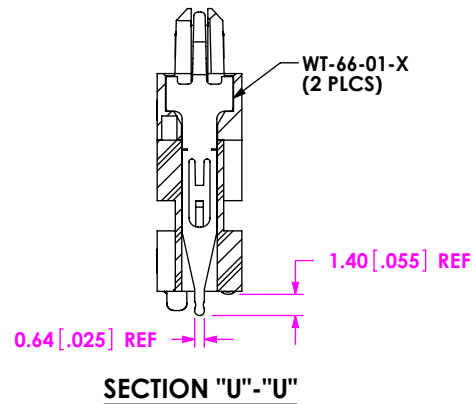
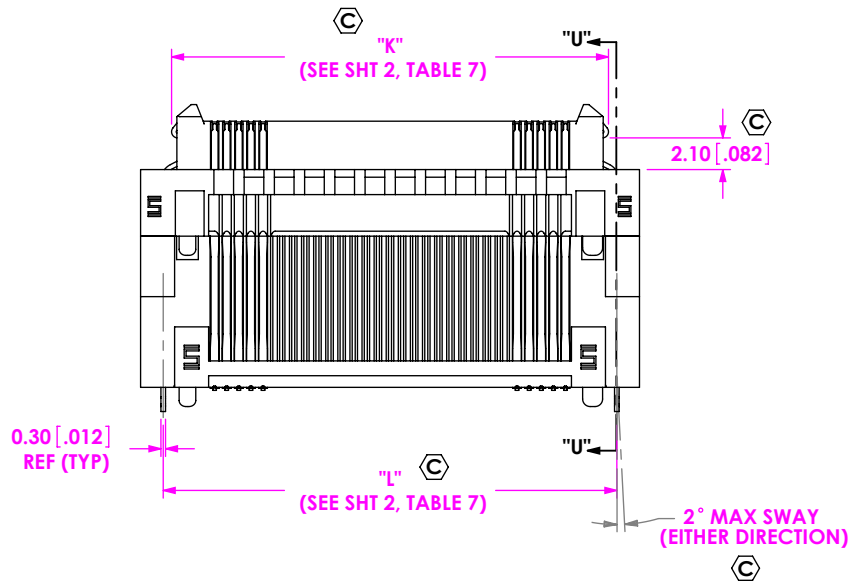

FIG 8
 (**ERM8-030-15.0-X-DV-L SHOWN)
 (SAME AS FIG. 7, EXCEPT AS SHOWN)
 ***NOT TOOLED

PROPRIETARY NOTE
 THIS DOCUMENT CONTAINS INFORMATION CONFIDENTIAL AND PROPRIETARY TO SAMTEC, INC. AND SHALL NOT BE REPRODUCED OR TRANSFERRED TO OTHER DOCUMENTS OR DISCLOSED TO OTHERS OR USED FOR ANY PURPOSE OTHER THAN THAT WHICH IT WAS OBTAINED WITHOUT THE EXPRESSED WRITTEN CONSENT OF SAMTEC, INC.

DO NOT SCALE DRAWING

SHEET SCALE: 2:1

samtec

520 PARK EAST BLVD, NEW ALBANY, IN 47150
 PHONE: 812-944-6733 FAX: 812-948-5047
 e-Mail info@SAMTEC.com code 55322

DESCRIPTION:
0.8MM EDGE RATE TERMINAL ASSEMBLY

DWG. NO.
ERM8-XXX-XX.X-X-DV-XXXX-TR

BY: KNOWLDEN 9/27/2005 SHEET 5 OF 6

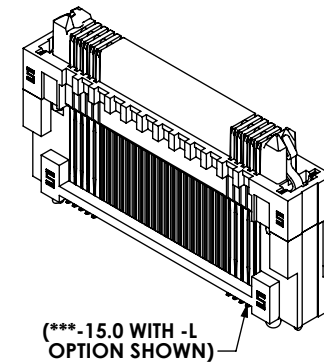
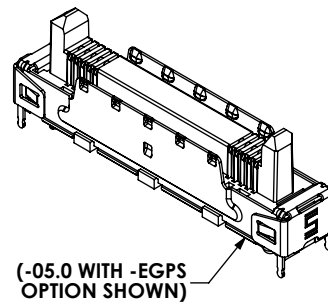
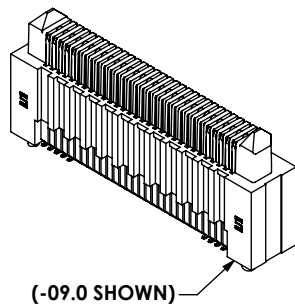
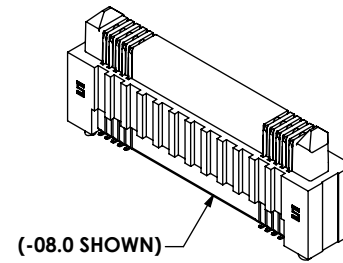
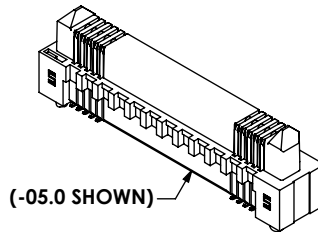
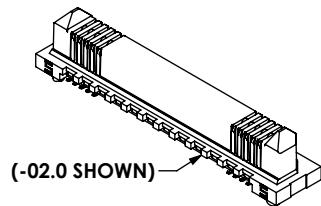

PROPRIETARY NOTE

THIS DOCUMENT CONTAINS INFORMATION CONFIDENTIAL AND PROPRIETARY TO SAMTEC, INC. AND SHALL NOT BE REPRODUCED OR TRANSFERRED TO OTHER DOCUMENTS OR DISCLOSED TO OTHERS OR USED FOR ANY PURPOSE OTHER THAN THAT WHICH IT WAS OBTAINED WITHOUT THE EXPRESSED WRITTEN CONSENT OF SAMTEC, INC.

DO NOT SCALE DRAWING

SHEET SCALE: 2:1

samtec

520 PARK EAST BLVD, NEW ALBANY, IN 47150
PHONE: 812-944-6733 FAX: 812-948-5047
e-Mail info@SAMTEC.com code 55322

DESCRIPTION:

0.8MM EDGE RATE TERMINAL ASSEMBLY

DWG. NO.

ERM8-XXX-XX.X-X-DV-XXXX-TR

BY: KNOWLDEN 9/27/2005 SHEET 6 OF 6