

- NOTES:  
 1. TERMINAL PUSHOUT FORCE: 3 lbs.  
 2. ASSEMBLE GOLD PLATED END AS SHOWN.  
 3. Ⓢ REPRESENTS CRITICAL DIMENSION.  
 4. TERMINALS TO BE FLUSH TO .010 [2.5] BELOW TOP OF SHROUD.  
 5. TST-1XX-04-X-D-RA-XX ASSEMBLIES ARE TO BE PACKAGED IN A PT-1-24-01-40, TUBE WITH TWO TP-13 PLUGS PER TUBE (ALL POSITIONS).  
 6. SAMTEC LOGO MAY VARY IN LOCATION.

TST-1XX-XX-X-X-XX-XX  
 No. OF POSITIONS  
 -02 (STRAIGHT ONLY)  
 -03 THRU -18 & 20, 24, 25, 28, 30, 32, 36  
 POLARIZE OPTION  
 -XX INDICATES POSITION OMITTED  
 OPTION  
 BLANK: STRAIGHT (STYLE -04 & -05 N/A)  
 -RA: RIGHT ANGLE (STYLE -01, -02, & -03 N/A) (SEE TUBE TABLE FOR PACKAGING)  
 -LL: LOCKING LEAD  
 -LA: -RA OPTION WITH -LL OPTION (SEE TUBE TABLE FOR PACKAGING)  
 LEAD STYLE  
 SEE TABLE 1  
 ROW OPTION  
 -D: DOUBLE  
 -S: SINGLE

PLATING SPECIFICATION  
 -G: GOLD-.000010 Au (CONTACT AREA) OVER .000050 Ni  
 -T: TIN-.000200 Sn OVER .000050 Ni  
 -S: SELECTIVE-.000030 Au (CONTACT AREA), .000200 Sn ON TAIL, OVER .000050 Ni  
 -L: SELECTIVE-.000010 Au (CONTACT AREA), .000200 Sn ON TAIL, OVER .000050 Ni  
 -H: GOLD-.000030 Au (CONTACT AREA) OVER .000050 Ni  
 -F: FLASH SELECTIVE GOLD-.000003 Au (CONTACT AREA), .000200 Sn ON TAIL, OVER .000050 Ni  
 -P: GOLD FLASHED PALLADIUM NICKEL-.000003 Au OVER .000030 PdNi (CONTACT AREA), .000150 Sn ON TAIL, OVER .000050 Ni

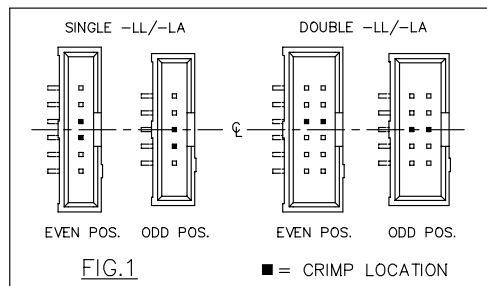
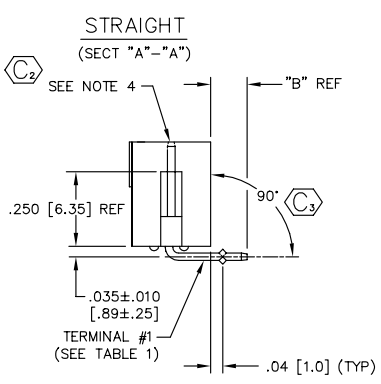
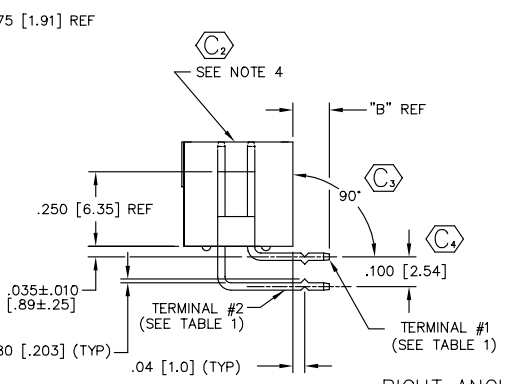
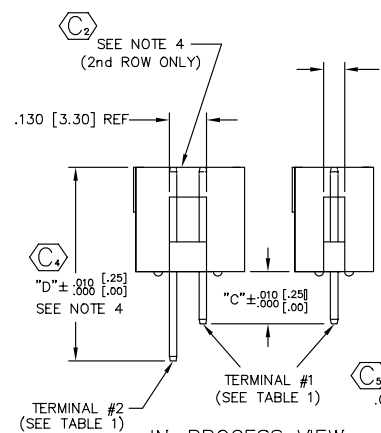
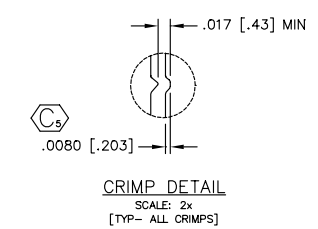
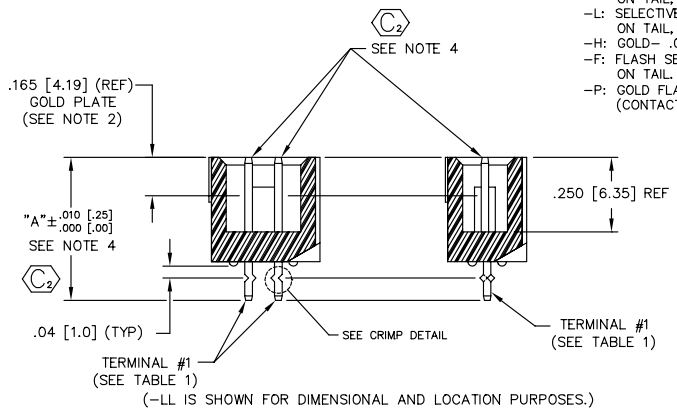
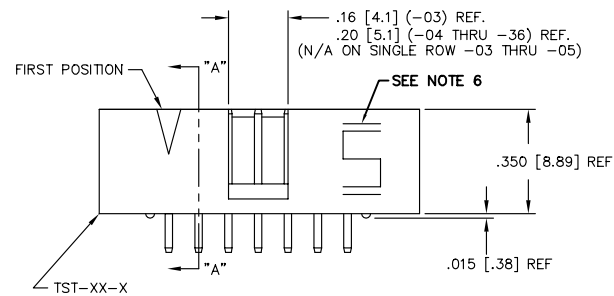

TABLE 1

LEAD STYLE	"A"	"B"	"C" NO RA REPRESS	"C" WITH RA REPRESS	"D"	TERMINAL #1	TERMINAL #2
-01	.480 [12.19]	-----	-----	-----	-----	T-1S6-17-X-2	-----
-02	.530 [13.46]	-----	-----	-----	-----	T-1S6-08-X-2	-----
-03	.930 [23.62]	-----	-----	-----	-----	T-1S6-11-X-2	-----
-04	-----	.130 [3.30]	.280 [7.11]	.350 [8.89]	.830 [21.08]	T-1S6-15-X-2	T-1S6-10-X-2
-05	-----	.230 [5.84]	.380 [9.65]	.450 [11.43]	.930 [23.62]	T-1S6-09-X-2	T-1S6-11-X-2

MATERIAL:  
 VALOX 420 SE0 OR 553, OR CELANESE 3316  
 COLOR: BLACK  
 TERMINAL:  
 PHOSPHOR BRONZE, ALLOY No 510, GRADE A, FEDERAL SPEC. QQ-B-750, 3/4 HARD, 95 - 105 KPSI TENSILE.  
 MATERIAL THICKNESS: .0250 ± .0003 [6.35 ± .0076]

MISC\MKTG TST-MKT  
**samtec**  
 520 PARK EAST BLVD. NEW ALBANY, INDIANA 47150  
 PHONE (812) 944-6733 P.O. BOX 1147  
 CODE 55322  
 MADE BY: JORDAN 2-18-87 TST-1XX-XX-X-X-XX-XX  
 SHEET 1 OF 1

**PROPRIETARY NOTE**  
 THIS DOCUMENT CONTAINS INFORMATION CONFIDENTIAL AND PROPRIETARY TO SAMTEC INC. AND SHALL NOT BE REPRODUCED OR TRANSMITTED IN ANY FORM OR BY ANY MEANS, ELECTRONIC OR MECHANICAL, INCLUDING PHOTOCOPYING, RECORDING, OR BY ANY INFORMATION STORAGE AND RETRIEVAL SYSTEM, WITHOUT THE WRITTEN CONSENT OF SAMTEC INC.

Do not scale from this print.