

TABLE 1						
STYLE	TAIL/OPTION	"A"	"B"	TERMINAL #1	TERMINAL #2	TERMINAL #3
-01	-RA	.103 [2.62]	.126 [3.20]	T-1S13-02-XX-2	T-1S13-03-XX-2	T-1S13-17-XX-2
-01	-FC	.139 [3.53]	.126 [3.20]	T-1S13-19-XX-2	T-1S13-22-XX-2	N/A
-01	RA W/END SHROUD	.139 [3.53]	.126 [3.20]	T-1S13-19-XX-2	T-1S13-22-XX-2	N/A
-01	*-FE	.287 [7.29]	.126 [3.20]	T-1S13-22-XX-2	T-1S13-28-XX-2	N/A
-04	-RA	.100 [2.54]	.075 [1.91]	T-1S13-20-XX-2	T-1S13-08-XX-2	N/A
-04	-FC	.150 [3.81]	.075 [1.91]	T-1S13-02-XX-2	T-1S13-03-XX-2	N/A
-04	RA W/END SHROUD	.150 [3.81]	.075 [1.91]	T-1S13-02-XX-2	T-1S13-03-XX-2	N/A
-05	-RA	.090 [2.29]	.065 [1.65]	T-1S13-07-XX-2	T-1S13-13-XX-2	N/A
-05	-FC	.160 [4.06]	.065 [1.65]	T-1S13-02-XX-2	T-1S13-03-XX-2	N/A
-05	RA W/END SHROUD	.160 [4.06]	.065 [1.65]	T-1S13-02-XX-2	T-1S13-03-XX-2	N/A

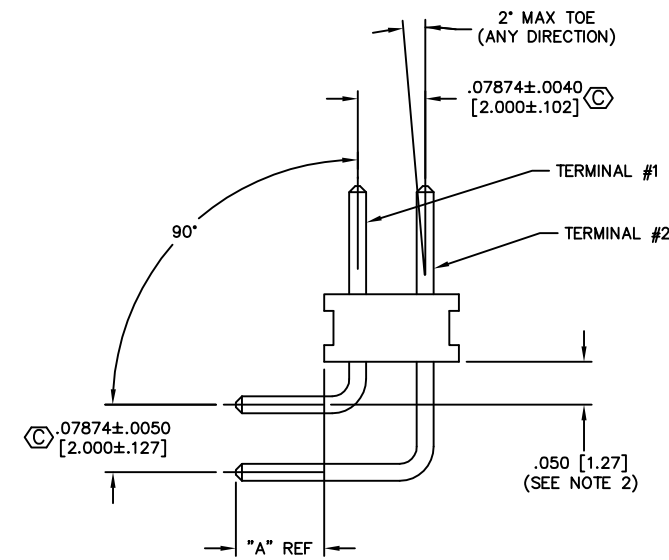
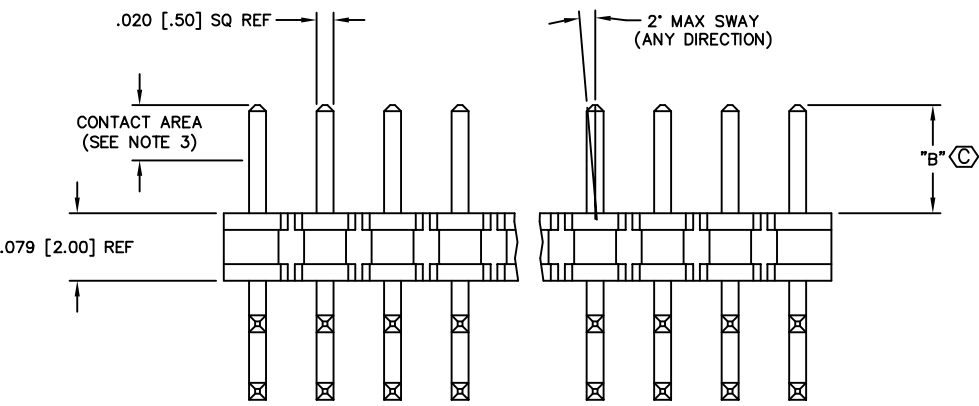
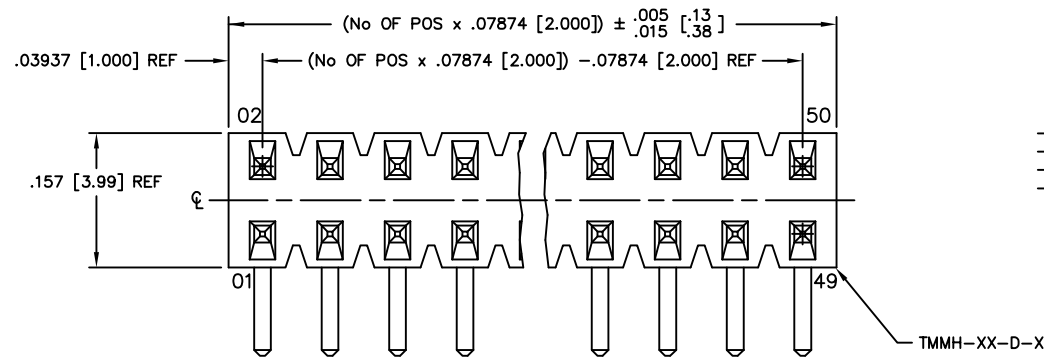

FIG 1

PLATING SPECIFICATION
 -L: LIGHT SELECTIVE GOLD (USE T-1S13-XX-L-2)
 -F: FLASH GOLD (USE T-1S13-XX-F-2)
 -S: SELECTIVE GOLD (USE T-1S13-XX-S-2)
 -G: GOLD (USE T-1S13-XX-G-2)
 -T: TIN (USE T-1S13-XX-T-2)
 -H: HEAVY GOLD (USE T-1S13-XX-H-2)
 -TM: MATTE TIN (USE T-1S13-XX-T-2)
 -LM: LIGHT SELECTIVE GOLD/MATTE TIN TAIL (USE T-1S13-XX-L-2)
 -FM: FLASH GOLD/MATTE TIN TAIL (USE T-1S13-XX-F-2)
 -SM: SELECTIVE GOLD/MATTE TIN TAIL (USE T-1S13-XX-S-2)

ROW OPTION
 -D: DOUBLE (USE TMMH-XX-D-X)
 -T: TRIPLE (USE TMMH-XX-T-X) (AVAILABLE WITH -01 LEAD STYLE ONLY.)

* = TAIL OPTION TO BE USED ON RIGHT ANGLE ONLY

- NOTES:
 1. PARTS MAY BE CUT TO POSITION.
 2. MEASURED AT BEND RADIUS, NOT AT END OF PIN.
 3. GOLD PLATING TO BE ON POST, TIN PLATING ON TAIL.
 4. Ⓢ REPRESENTS A CRITICAL DIMENSION.
 5. MINIMUM PUSHOUT FORCE: 1.0 LB.
 6. NOTE DELETED.
 7. MAX CUT FLASH TO BE .020.

PACKAGING VIEW

* ONLY TUBE POSITIONS -05 THROUGH -50
 SCALE: .5x

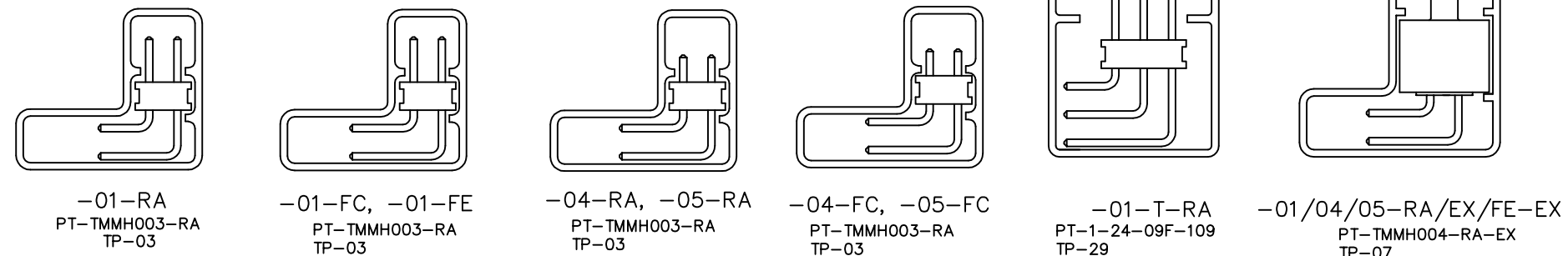

PROPRIETARY NOTE
 THIS DOCUMENT CONTAINS INFORMATION CONFIDENTIAL AND PROPRIETARY TO SAMTEC INC. AND SHALL NOT BE REPRODUCED OR TRANSMITTED TO OTHER DOCUMENTS OR DISCLOSED TO OTHERS OR USED FOR ANY PURPOSE OTHER THAN THAT FOR WHICH IT WAS OBTAINED WITHOUT THE EXPRESSED WRITTEN CONSENT OF SAMTEC INC.



520 PARK EAST BLVD. NEW ALBANY, INDIANA 47150
 PHONE (812) 944-6733 P.O. BOX 1147
 CODE 55322